

Bordeaux Graph Workshop 2019

LaBRI, Bordeaux, France
October 28 – 31, 2019

Program committee

Csilla Bujtás (*University of Ljubljana, Ljubljana, SLOVENIA*)
Kathie Cameron (*Wilfrid Laurier University, Waterloo, CANADA*)
Paul Dorbec (*University of Caen Normandy, Caen, FRANCE*)
Pavol Hell (*Simon Fraser University, Burnaby, CANADA*)
Hervé Hocquard (*LaBRI, University of Bordeaux, Bordeaux, FRANCE*)
František Kardoš (*LaBRI, University of Bordeaux, Bordeaux, FRANCE*)
Hamamache Kheddouci (*LIRIS - University Claude Bernard, Lyon, FRANCE*)
Arnaud Pêcher (*LaBRI - University of Bordeaux, FRANCE*)
Alexandre Pinlou (*LIRMM - University of Montpellier, FRANCE*)
André Raspaud (*LaBRI - University of Bordeaux, FRANCE*)
Carsten Thomassen (*Technical University of Denmark, Copenhagen, DENMARK*)
Olivier Togni (*Le2i - University of Bourgogne, Dijon, FRANCE*)
Annegret Wagler (*LIMOS - University Blaise Pascal, Clermont-Ferrand, FRANCE*)
Gilles Zémor (*IMB - University of Bordeaux, FRANCE*)

Organizing committee

O. Baudon
A. Blanché
M. Bonamy
N. Bonichon
A. Dantes
O. Delmas
F. Foucaud
K. Guérin
H. Hocquard
F. Kardoš
R. Klasing
D. Lajou
J. Narboni
P. Ouvrard
A. Pêcher
A. Raspaud
M. Senhaji
E. Sopena

Sponsors

LaBRI
Université de Bordeaux
CNRS
Bordeaux INP Aquitaine
ANR HOSIGRA
TBM (Transports Bordeaux Métropole)

Permanent URL • <http://bgw.labri.fr>

Contents

Invited talks	6
The global structure of large locally sparse graphs	6
<u>Ross Kang</u>	
Algebraic methods in parameterized graph algorithms	6
<u>Łukasz Kowalik</u>	
Graphs representing algebras	6
<u>Jaroslav Nešetřil</u>	
Projective flows, configurations, and the structure of cubic graphs	7
<u>Martin Škoviera</u>	
Variants of the Erdős–Sós Conjecture	7
<u>Maya Stein</u>	
Algorithms for (theta, wheel)-free graphs	7
<u>Kristina Vušković</u>	
Contributed talks	9
Colourings of cubic graphs inducing monochromatic subgraphs	10
<u>Marien Abreu, Jan Goedgebeur, Domenico Labbate and Giuseppe Mazzuocolo</u>	
The Orthogonal Colouring Game	14
<u>Stephan Dominique Andres, Melissa Huggan, Fionn Mc Inerney, Richard J. Nowakowski and François Dross</u>	
IB- and MB-homogeneous graphs	18
<u>Andrés Aranda</u>	
Eternal domination on digraphs and orientations of graphs	22
<u>Guillaume Bagan, Alice Joffard and Hamamache Kheddouci</u>	
On identifying codes in line digraphs	26
<u>Camino Balbuena, Cristina Dalfó and Berenice Martínez-Barona</u>	
Characterizing identifying codes from the spectrum of a graph or digraph	30
<u>Camino Balbuena, Cristina Dalfó and Berenice Martínez-Barona</u>	
Connecting edge-colouring	34
<u>Jørgen Bang-Jensen, Thomas Bellitto and Anders Yeo</u>	
Linear transformations between colorings in chordal graphs	38
<u>Valentin Bartier and Nicolas Bousquet</u>	
Domination versus edge domination	42
<u>Julien Baste, Maximilian Fürst, Michael A. Henning, Elena Mohr and Dieter Rautenbach</u>	
Bounding and approximating minimum maximal matchings in regular graphs	45
<u>Julien Baste, Maximilian Fürst, Michael A. Henning, Elena Mohr and Dieter Rautenbach</u>	
Linear programming based approximation for unweighted induced matchings — breaking the Δ barrier	48
<u>Julien Baste, Maximilian Fürst and Dieter Rautenbach</u>	
Bounding the broadcast domination number by the multipacking number	52
<u>Laurent Beaudou, Richard Brewster, Florent Foucaud and Bohdana Mitchell</u>	
Bounds on Broadcast Independence	55
<u>Stéphane Bessy and Dieter Rautenbach</u>	
Triangle-free graphs with large packing chromatic number	58
<u>Ez-Zobair Bidine and Mustapha Kchikech</u>	
Optimizing dominating sets under constrained transformation	62
<u>Alexandre Blanché, Haruka Mizuta, Paul Ouvrard and Akira Suzuki</u>	

Smaller Induced-Universal Graph for Planar Graphs	65
<i>Marthe Bonamy, Cyril Gavoille and Michał Pilipczuk</i>	
Partition-crossing	69
<i>Csilla Bujtás and Zsolt Tuza</i>	
A note on the inflating enclosing ball problem	73
<i>Nikola K. Blanchard and Siargey Kachanovich</i>	
Counting authorised paths in constrained control-flow graphs	77
<i>Nikola K. Blanchard and Siargey Kachanovich</i>	
List homomorphisms of signed graphs	81
<i>Jan Bok, Richard Brewster, Pavol Hell and Nikola Jedličková</i>	
Extending Partial Orderings of Adjusted Interval Digraphs	85
<i>Jan Bok, Pavol Hell and Nikola Jedličková</i>	
Distributed recoloring on trees	88
<i>Marthe Bonamy, Paul Ouvrard, Mikaël Rabie, Jukka Suomela and Jara Uitto</i>	
Planar Graphs with Girth 20 are Additively 3-Choosable	92
<i>Axel Brandt, Nathan Tenpas and Carl Yerger</i>	
Trees Containing All the Odd-Degree Vertices	96
<i>Kathie Cameron</i>	
Large independent sets in triangle-free subcubic graphs; beyond planarity	99
<i>Wouter Cames van Batenburg, Jan Goedgebeur and Gwenaël Joret</i>	
The domination number of cylindrical graphs	103
<i>José Juan Carreño, José Antonio Martínez and María Luz Puertas</i>	
On star edge colorings of bipartite and subcubic graphs	106
<i>Carl Johan Casselgren, Jonas Granholm and André Raspaud</i>	
A note on (3, 1)-choosability of planar graphs	108
<i>Carl Johan Casselgren, Jonas Granholm and André Raspaud</i>	
Kernelization of Graph Hamiltonicity: Proper H-Graphs	110
<i>Steven Chaplick, Fedor Fomin, Petr Golovach, Peter Zeman and Dušan Knop</i>	
Two-dimensional partial cubes	114
<i>Victor Chepoi, Kolja Knauer and Manon Philibert</i>	
Graph Centralities and Cascading Failures in Networks	118
<i>Francesc Comellas and Llorenç Sánchez</i>	
Graph Unfoldings, Graph Coverings and Regular Trees	122
<i>Bruno Courcelle and Yves Métivier</i>	
Harnessing the power of atoms	125
<i>Konrad K. Dabrowski, Tomáš Masařík, Jana Novotná, Daniël Paulusma and Paweł Rzążewski</i>	
Hull number in the convexity of induced paths of order up to $k \geq 3$	128
<i>Mitre C. Dourado, Lucia D. Penso and Dieter Rautenbach</i>	
Hypergraph matchings and blow-up lemmas	132
<i>Stefan Ehard, Stefan Glock and Felix Joos</i>	
Parameterized complexity of edge-coloured and signed graph homomorphisms	136
<i>Florent Foucaud, Hervé Hocquard, Dimitri Lajou, Valia Mitsou and Théo Pierron</i>	
Asymptotic growth rate of square	140
<i>Silvère Gangloff and Alexandre Talon</i>	
Packing colorings of subcubic outerplanar graphs	143
<i>Nicolas Gastineau, Olivier Togni and Boštjan Brešar</i>	
Monochromatically-connecting colorings of strong digraphs	146
<i>Diego González-Moreno, Mucuy-kak Guevara and Juan José Montellano-Ballesteros</i>	
Self contained graphs and twin graph conjectures	150
<i>Geňa Hahn</i>	
Resolving Sets of Vertices in Flower Snarks	151
<i>Anni Hakanen, Ville Junnila, Tero Laihonen and María Luz Puertas</i>	
Long A-B-paths have the edge-Erdős-Pósa property	155
<i>Matthias Heinlein and Arthur Ulmer</i>	
Linear MIM-Width of Trees	159
<i>Svein Høgemo, Jan Arne Telle and Erlend Raa Vågset</i>	
Ramsey properties of graphs of girth $3 \leq g \leq 8$	163
<i>Jan Hubička, Matěj Konečný and Jaroslav Nešetřil</i>	

Extending partial automorphisms	167
<i>Jan Hubička, Matěj Konečný and Jaroslav Nešetřil</i>	
The chromatic number and switching chromatic number of 2-edge-colored graphs of bounded degree	171
<i>Fabien Jacques, Mickael Montassier and Alexandre Pinlou</i>	
On the 4-color theorem for signed graphs	175
<i>František Kardoš and Jonathan Narboni</i>	
Automorphism groups of planar and nonplanar maps in linear time	179
<i>Ken-ichi Kawarabayashi, Bojan Mohar, Roman Nedela and Peter Zeman</i>	
Upper Traceable Number of Circulant and Generalized Petersen Graphs	183
<i>Mustapha Kchikech and Laila Loudiki</i>	
On superperfection of edge intersection graphs of paths	187
<i>Hervé Kerivin and Annegret Wagler</i>	
Fractional eternal domination	191
<i>Devvrit Khatri, Aaron Krim-Yee, Nithish Kumar, Gary MacGillivray, Ben Seamone, Virgélot Virgile and AnQi Xu</i>	
The existence of a path-factor involving paths of order eleven	194
<i>Keiko Kotani</i>	
r -hued coloring of planar graphs with girth at least 8	196
<i>Hoang La, Mickael Montassier, Alexandre Pinlou and Petru Valicov</i>	
Switching (m, n) -edge-coloured mixed graphs	200
<i>Etienne Leclerc and Gary MacGillivray</i>	
Edge Degeneracy: Algorithmic and Structural Results	204
<i>Stratis Limnios, Christophe Paul, Joanny Perret and Dimitrios M. Thilikos</i>	
A 3-edge-coloring algorithm	208
<i>Robert Lukotka and Jakub Tětek</i>	
Medial graphs of bipartite plane graphs are 3-choosable	212
<i>Borut Lužar, Mária Maceková, Roman Soták and François Dross</i>	
Berge-Tutte type formula for an f -leaf-tree	215
<i>Shun-ichi Maezawa and Haruhide Matsuda</i>	
Packing Directed Circuits Quarter-Integrally	218
<i>Tomáš Masařík, Irene Muzi, Marcin Pilipczuk, Paweł Rzqzewski and Manuel Sorge</i>	
On the Circumference of 3-Connected Maximal 1-Planar Graphs	222
<i>Samuel Mohr</i>	
A new lower bound of the number of contractible edges on longest cycles in a 3-connected graph	224
<i>Shunsuke Nakamura</i>	
Signed graphs with bicircular matroids	228
<i>Konstantinos Papalamprou</i>	
A Brooks-like result for graph powers	231
<i>Théo Pierron</i>	
On the Minimum Skewness of Certain Classes of Graphs	235
<i>Val Pinciu</i>	
The 1–2–3 Conjecture and regular graphs	239
<i>Jakub Przybyło</i>	
Distinguishing vertices of a graph - palettes and automorphisms	243
<i>Mariusz Woźniak</i>	

Invited talks

Ross Kang – **The global structure of large locally sparse graphs**

Radboud University Nijmegen

The structure of triangle-free graphs has long played an influential role in the development of combinatorics and graph theory. Both Mantel's (1907) and Ramsey's (1930) theorems yield global structure from the local property of having no edges in any neighbourhood. I have recently made some basic explorations in this classic area, both beginning and ending in list colouring problems.

The first part concerns a recent conjecture on bipartite induced density in triangle-free graphs, which innocently originated in the study of separation choosability. I will discuss how the conjecture has stimulated and coincided with a small burst of related activity and new directions.

The second part presents a new structural framework (that includes list colouring) for locally sparse graphs. This generalises and strengthens many landmark results in the area, including for example those of Ajtai, Komlós, Szemerédi (1981), Shearer (1983), Johansson (1996), Alon (1996), Alon, Krivelevich, Sudakov (1999), and Molloy (2019). It is built around a technique inspired by statistical physics –namely, a local analysis of the hard-core model.

This covers joint work with, variously, Wouter Cames van Batenburg, Ewan Davies, Louis Esperet, Rémi de Joannis de Verclos, François Pirot, Jean-Sébastien Sereni, and Stéphan Thomassé.

Łukasz Kowalik – **Algebraic methods in parameterized graph algorithms**

University of Warsaw

Connections between graph theory and algebra have led to several elegant and powerful algorithms, with perhaps most prominent examples being counting spanning trees using Kirchoff's matrix tree theorem and Lovasz' algorithm for testing if a graph admits a perfect matching using the Tutte matrix. In the recent ten years, a number of algorithms of similar flavour have appeared in the area of parameterized algorithms. In the lecture I will describe an algorithm for finding a k -vertex path in an n -vertex graph due to Björklund, Husfeldt, Kaski and Koivisto, running in time $O(1.66^k n)$. Next, I will show a number of adaptations of the basic technique to get even faster algorithms in restricted settings (like bounded degree graphs) or to related problems including finding trees instead of paths, the graph motif problem.

Joint work with A. Björklund, V. Kamat, P. Kaski, and M. Zehavi.

Jaroslav Nešetřil – **Graphs representing algebras**

Charles University

Groups, monoids and categories by graphs in relationship to sparse hierarchy of classes of graphs. A joint work with P. Ossona de Mendez.

Martin Škoviera – Projective flows, configurations, and the structure of cubic graphs

Comenius University

We present a unifying approach to several important conjectures in graph theory in terms of nowhere-zero flows on cubic graphs where flow-values are points of a configuration of lines in a projective space and outflow-patterns are triples of points sharing a line of the configuration. We then concentrate on two conjectures where this approach proves useful.

The Berge conjecture suggests that every bridgeless cubic graph can have its edges covered by at most five perfect matchings. It turns out that graphs that cannot be covered with four perfect matchings are extremely rare and difficult to find. We show that they can be efficiently studied by means of flows whose outflow patterns form a configuration of six lines spanned by four points of the 3-dimensional projective geometry $PG(3, 2)$ in general position. We employ this knowledge to providing a great variety of constructions of cubic graphs that require (at least) five perfect matchings to cover their edges, thereby extending and generalising all previously known constructions of such graphs.

The shortest cycle conjecture of Alon, Tarsi, and Jaeger states that every bridgeless graph has a cycle cover of length at most $7/5 \cdot m$ where m is the number of edges. This conjecture is particularly interesting for cubic graphs, where the largest values of the ratio between the length of a shortest cycle cover and the number of edges are known. Although the $7/5$ bound is reached by infinitely many graphs, all cyclically 4-edge-connected cubic graphs where the length of a shortest cycle cover is known have covering ratio close to the natural lower bound which equals $4/3$. A conjecture of Brinkmann et al. even states that every such graph has a cycle cover of length at most $4/3 \cdot m + o(m)$. We disprove this conjecture by displaying a family of graphs whose shortest cycle cover has length at least $(4/3 + 1/69) \cdot m$. The family was found by using flows with values in the 6-line configuration in $PG(3, 2)$ mentioned above.

The talk is based on a joint work with Edita Máčajová.

Maya Stein – Variants of the Erdős–Sós Conjecture

University of Chile

This talk will revolve around the question of what type of degree conditions can force the existence of all trees of a certain size as subgraphs. A well-known conjecture in this direction, namely the Erdős–Sós Conjecture, suggests that every graph of average degree $> k - 1$ contains each tree with k edges as a subgraph. Note that $k \in \mathbb{N}$ is just any number, not necessarily related to the order of the host graph.

There are some newer conjectures aiming at the same conclusion (containment of each trees with k edges). These conjectures replace the condition on the average degree with similar conditions either on the median degree, or on both the maximum and minimum degree, or on other invariants related to the degree sequence. There are also generalizations of the Erdős–Sós Conjecture to hypergraphs and to digraphs.

We will survey the known results and open conjectures of this type, with special emphasis on accessible open questions, and giving some insight into the methods employed in the different approaches.

Kristina Vušković – Algorithms for (theta, wheel)-free graphs

University of Leeds

A theta is a subdivision of $K_{2,3}$ and a wheel is a graph that consist of a chordless cycle of length at least 4 and a vertex that has at least 3 neighbors on the cycle. In joint work with Trotignon and Radovanović we obtained a structure theorem for graphs that do not contain thetas and wheels as induced subgraphs (i.e. (theta, wheel)-free graphs) and several of its algorithmic consequences.

We decompose (theta, wheel)-free graphs using clique cutsets and 2-joins into graphs that are essentially formed of a line graph of a triangle-free chordless graph plus a (possibly empty) clique (that attaches to the rest of the graph in a particular way). A 2-join is an edge cutset that appears in decomposition theorems for several complex hereditary classes, such as perfect graphs, even-hole-free graphs and others. In these decomposition theorems 2-joins are used together with vertex cutsets that are stronger than clique

cutsets, such as star cutsets and their generalizations (which are much harder to use in algorithms). This is a first example of a decomposition theorem that uses just the combination of clique cutsets and 2-joins. This has several consequences.

First, we can easily transform our decomposition theorem into a complete structure theorem for (theta, wheel)-free graphs, i.e. we show how every graph in the class can be built starting from basic graphs that can be explicitly constructed, and gluing them together by prescribed composition operations, and all graphs built this way are in the class. Such structure theorems are rare for hereditary graph classes, only a few examples are known.

Next, we construct a polynomial-time decomposition based recognition algorithm. Recognizing classes of graphs defined by excluding different combinations of Truemper configurations (i.e. wheels, thetas, prisms and pyramids) is a much studied problem. For some combinations the problem is known to be polynomial (e.g. recognizing pyramids and thetas), whereas for others it is NP-complete (e.g. recognizing prisms and wheels). The class of (theta, wheel)-free graphs was the last of these types of recognition problems that was open, which we have now resolved.

We then use the decomposition theorem to obtain polynomial-time algorithms for weighted stable set, weighted clique and vertex coloring problems. For the weighted stable set problem, it was essential to decompose the graph using a sequence of non-crossing 2-joins. The weighted clique problem we solve by first showing the existence of a bisimplicial vertex (a vertex whose neighborhood partitions into 2 cliques). This is done elegantly by using the existence of an extreme 2-join (a 2-join whose one block of decomposition does not have a 2-join). We also prove that every (theta, wheel)-free graph with maximum clique size w admits a coloring with at most $\max\{w, 3\}$ colors.

Finally, we obtain a polynomial-time algorithm for induced version of k-linkage problem (for fixed k): given k distinct pairs of vertices (s_i, t_i) of a graph G , decide whether there are k vertex-disjoint paths $P_i = s_i \dots t_i, i = 1, \dots, k$, such that there are no edges between the vertices of these paths.

Contributed talks

Colourings of cubic graphs inducing monochromatic subgraphs

Marién Abreu^{1*}, Jan Goedgebeur^{2†}, Domenico Labbate^{1*} and Giuseppe Mazzuoccolo³,

¹ Dipartimento di Matematica, Informatica ed Economia, Università degli Studi della Basilicata – Potenza, Italy.

² Department of Applied Mathematics, Computer Science and Statistics, Ghent University, Ghent, Belgium.

³ Dipartimento di Informatica, Università degli Studi di Verona, Italy.

EXTENDED ABSTRACT

A k -bisection of a bridgeless cubic graph G is a 2-colouring of its vertex set such that (i) the colour classes have the same cardinality and (ii) all connected components in the two subgraphs induced by the colour classes (*monochromatic components* in what follows) have order at most k . Note that the colourings not necessarily have to be proper.

There are several papers in literature considering 2-colourings of regular graphs which satisfy condition (ii), but not necessarily condition (i), see [3, 6, 11, 13]. In particular, it is easy to see that every cubic graph has a 2-colouring where all monochromatic connected components are of order at most 2, but, in general, such a colouring does not satisfy condition (i) and so it is not a 2-bisection. Thus, the existence of a 2-bisection in a cubic graph is not guaranteed. For instance, the Petersen graph does not admit a 2-bisection. However, the Petersen graph is an exception since it is the only known bridgeless cubic graph without a 2-bisection. This led Ban and Linial to state the following conjecture:

Conjecture 1 (Ban–Linial [5]) *Every bridgeless cubic graph admits a 2-bisection, except for the Petersen graph.*

A similar problem for the edge set of a cubic graph has been studied. A *linear forest* is a forest whose components are paths and a *linear partition* of a graph G is a partition of its edge set into linear forests (cf. [9, 12]). Wormald made the following conjecture:

Conjecture 2 (Wormald [15]) *Let G be a cubic graph with $|E(G)| \equiv 0 \pmod{2}$ (or equivalently $|V(G)| \equiv 0 \pmod{4}$). Then there exists a linear partition of G into two isomorphic linear forests.*

Note that the statement of Wormald’s Conjecture is equivalent to the statement that *there exists a 2-edge colouring of $E(G)$ such that the two monochromatic subgraphs are isomorphic linear forests*. We define such a 2-edge colouring to be a *Wormald colouring*.

The main aim of the paper [2] on which this talk is based is to provide evidence of a strong relation of the two previous conjectures with the following conjecture proposed by Ando [4] in the 1990’s.

Conjecture 3 (Ando [4]) *Every cubic graph admits a bisection such that the two induced monochromatic subgraphs are isomorphic.*

Note that the statement of Ando’s Conjecture is equivalent to the statement that *a cubic graph G admits a 2-vertex colouring of G , $c_V : V(G) \rightarrow \{B, W\}$, such that the monochromatic induced subgraphs are isomorphic*. We call this an *Ando colouring*. Trivially, in order to have isomorphic monochromatic induced subgraphs such a 2-colouring is a bisection.

In the paper we use two different approaches: the first one dealing with 2-bisections and the second one with linear forests using *Wormald Colouring*. In this talk, we will mainly focus on the first approach and relations between Ban–Linial and Ando’s Conjectures.

First of all, we provide evidence of a strong relation of the conjectures of Ban–Linial and Wormald with Ando’s conjecture:

*The first and third author were partially supported by a grant of the group GNSAGA of INdAM and by the Italian Ministry Research Project PRIN 2012 “Geometric Structures, Combinatorics and their Applications”.

†The second author was supported by a postdoctoral fellowship of the Research Foundation Flanders (FWO).

Proposition 4 *Let G be a bridgeless cubic graph. If G is a counterexample for Ando’s Conjecture, then it is also a counterexample for the Ban–Linial Conjecture.*

The previous proposition implies that every cubic graph with a 2–bisection is not a counterexample for Ando’s Conjecture. In particular, note that in the proof we show that a 2–bisection is always a bisection with isomorphic parts.

Furthermore, we also give theoretical and computational evidence in their support. Indeed, we prove Ban–Linial’s conjecture (and by Proposition 4 also Ando’s Conjecture) for cubic cycle permutation graphs and in a separate paper [1], we have proved Ban–Linial’s conjecture for claw–free cubic graphs.

As mentioned before, only one example of bridgeless cubic graph without a 2–bisection is known (i.e. the Petersen graph). On the other hand, an infinite family of 1–connected cubic graphs with no 2–bisection is constructed in [8]:

Take the module L_h ($h \geq 0$) depicted in Figure 1. Note that L_0 is $K_{3,3}$ with an edge subdivided with a new vertex.

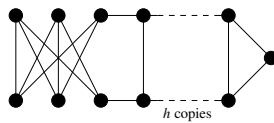

Figure 1: The module L_h .

Let T_{ijk} be the graph obtained by taking L_i , L_j and L_k and adding a new vertex adjacent to the three vertices of degree 2.

It is proved in [8] that T_{ijk} does not admit a 2–bisection for all possible non–negative values of i, j and k . We prove that all members of this family admit a 3–bisection with isomorphic parts.

Proposition 5 *For any $i, j, k \geq 0$, the graph T_{ijk} admits a 3–bisection with isomorphic parts.*

Computationally we have seen that:

Observation 6 *There are exactly 34 graphs among the cubic graphs with at most 32 vertices which do not admit a 2–bisection. All of these graphs, except the Petersen graph, have connectivity 1.*

So this implies that the smallest counterexample to the Ban–Linial Conjecture must have at least 34 vertices. Ban and Linial [5] have proved that every 3–edge colourable cubic graph admits a 2–bisection. We have also tested which snarks of order 34 and 36 admit a 2–bisection, which led to the following observation:

Observation 7 *The Petersen graph is the only snark up to 36 vertices which does not admit a 2–bisection.*

So this provides further evidence to support the correctness of Conjecture 1.

Moreover, we pose some open problems stronger than the above mentioned conjectures. First of all let us remark some properties of bisections with isomorphic parts i.e. (i) in all 2–bisections the two monochromatic induced subgraphs are isomorphic and they are obviously linear forests; (ii) all known graphs without a 2–bisection admit a 3–bisection with isomorphic parts which are linear forests, except the Petersen graph; (iii) the Petersen graph admits a 4–bisection with isomorphic parts which are linear forests.

This gives rise to the following natural question: *does every cubic graph admit a bisection with isomorphic parts and with the additional property that these parts are linear forests?*

To approach this problem, we observe that we can assume that both parts have maximum degree two.

Proposition 8 *Let G be a cubic graph admitting a bisection with isomorphic parts. Then G admits a bisection with isomorphic parts having maximum degree 2.*

Proposition 8 and previous remarks lead us to state the following strong version of Ando's Conjecture:

Conjecture 9 (Strong Ando Conjecture) *Every cubic graph admits a bisection such that the two induced subgraphs are isomorphic linear forests.*

Computationally, using a slightly modified version of algorithm used to test Ban-Linial's conjecture we obtain from Observation 6 that

Corollary 10 *The Strong version of Ando's conjecture (i.e. Conjecture 9) (and thus also Ando's original conjecture) does not have any counterexamples with less than 34 vertices.*

Finally, we would also like to point out, as mentioned earlier, that we can give a positive answer for some instances of Ando's Conjecture using either 2-bisections or linear forests. We find it interesting that the few possible *exceptions* for which the approach with 2-bisections is not feasible, are in the class of *not* 3-edge colourable cubic graphs. On the other hand, all known exceptions for which the approach with our strengthened version of Wormald colourings is not feasible, are in the class of 3-edge colourable cubic graphs. Note that, this indicates a promising possibility for a complete proof of Ando's Conjecture by proving that a given cubic graph cannot be an exception for both of these two approaches (at least for a bridgeless cubic graph).

As a by-product of studying 2-edge colourings of cubic graphs having linear forests as monochromatic components, we also give a negative answer to a problem posed by Jackson and Wormald in [12] (cf. also [14]) about certain decompositions of cubic graphs into linear forests.

The k -linear arboricity of a graph G , introduced by Habib and Péroche [10], is the minimum number of k -linear forests (forests whose connected components are paths of length at most k) required to partition the edge set of G , and it is denoted by $la_k(G)$. Bermond et al. [7] conjectured that $la_5(G) = 2$ for every cubic graph G ; in other words that the edge set of a cubic graph can be partitioned into two k -linear forests for all $k \geq 5$. The conjecture is proved by Thomassen in [14].

In the same paper, Thomassen remarks that 5 cannot be replaced by 4 because of the two cubic graphs of order 6, but up until now it was unknown if there exists a graph with at least eight vertices for which 5 cannot be replaced by 4.

In fact, Jackson and Wormald explicitly ask in [12] if it is true that every cubic graph of order at least eight can be decomposed in two 4-linear forests.

Problem 11 (Jackson and Wormald [12]) *Is it true that $la_4(G) = 2$ for all cubic graphs G with at least eight vertices?*

We give in Theorem 12 a negative answer to this question by showing that the Heawood graph cannot be decomposed in two k -linear forests for $k < 5$. We also computationally show that the two cubic graphs of order 6 and the Heawood graph are the only graphs with this property up to at least 28 vertices (cf. Observation 13).

Recall that the Heawood graph H is the point/line incidence graph of the Fano plane $PG(2, 2)$ which is bipartite, 3-regular, 3-arc transitive and has girth 6 and diameter 3.

Theorem 12 *Let H be the Heawood graph. Then, $la_4(H) > 2$.*

Observation 13 *The two cubic graphs of order 6 and the Heawood graph are the only cubic graphs up to at least 28 vertices which cannot be decomposed in two 4-linear forests.*

Following the flavour of what we have discussed previously and, particularly, about Wormald’s Conjecture, we wonder how we have to modify Thomassen’s result if we require to have two linear forests which are also isomorphic. Obviously, this only makes sense if we consider cubic graphs of order $0 \pmod{4}$. We have extended our program to take this into account and surprisingly, it turns out that we do not need paths of length more than four for all graphs of order at most 24:

Observation 14 *Every cubic graph with $|V| \equiv 0 \pmod{4}$ with at most 24 vertices has a decomposition into two isomorphic 4-linear forests.*

We leave the following strengthened version of Wormald’s Conjecture as an open problem:

Problem 15 *Does every cubic graph with $|V| \equiv 0 \pmod{4}$ have a decomposition into two isomorphic 4-linear forests?*

References

- [1] M. Abreu, J. Goedgebeur, D. Labbate, G. Mazzuocolo. A note on 2-bisections of claw-free cubic graphs. *Discrete Appl. Math.*, 244 (2018), 214–217.
- [2] M. Abreu, J. Goedgebeur, D. Labbate, G. Mazzuocolo. Colourings of cubic graphs inducing isomorphic monochromatic subgraphs. *J. Graph Theory*, (2019), DOI: 10.1002/jgt.22462.
- [3] N. Alon, G. Ding, B. Oporowski, D. Vertigan. Partitioning into graphs with only small components. *J. Combin. Theory Ser. B*, 87 (2003), 231–243.
- [4] K. Ando. Personal communication.
- [5] A. Ban, N. Linial. Internal Partitions of Regular Graphs. *J. Graph Theory*, 83 (2016), no. 1, 5–18.
- [6] R. Berke, T. Szabó. Relaxed two-coloring of cubic graphs. *J. Combin. Theory Ser. B*, 97 (2007), no. 4, 652–668.
- [7] J.C. Bermond, J.L. Fouquet, M. Habib, B. Péroche. On linear k -arboricity. *Discrete Math.*, 52 (1984), 123–132.
- [8] L. Esperet, G. Mazzuocolo, M. Tarsi. Flows and bisections in cubic graphs. *J. Graph Theory*, 86 (2017), no. 2, 149–158.
- [9] J.L. Fouquet, H. Thuillier, J.M. Vanherpe, A.P. Wojda. On isomorphic linear partitions in cubic graphs. *Discrete Math.*, 309 (2009), no. 22, 6425–6433.
- [10] M. Habib, B. Péroche. Some problems about linear arboricity. *Discrete Math.*, 41 (1982), 219–220.
- [11] P. Haxell, T. Szabó, G. Tardos. Bounded size components-partitions and transversals. *J. Combin. Theory Ser. B*, 88 (2003), 281–297.
- [12] B. Jackson, N.C. Wormald. On the linear k -arboricity of cubic graphs. *Discrete Math.*, 162 (1996), 293–297.
- [13] N. Linial, J. Matousek, O. Sheffet, G. Tardos. Graph colouring with no large monochromatic components. *Combin. Probab. Comput.*, 17 (2008), no. 4, 577–589.
- [14] C. Thomassen. Two-Coloring of the Edges of a Cubic Graph Such That Each Monochromatic Component Is a Path of Length at Most 5. *J. Comb. Theory Ser. B*, 75 (1999), no. 1, 100–109.
- [15] N. Wormald. Problem 13. *Ars Combinatoria*, 23 (1987), 332–334.

The Orthogonal Colouring Game ¹

Stephan Dominique Andres ¹, François Dross ², Melissa Huggan ³, Fionn Mc Inerney ²,
and Richard J. Nowakowski ³

¹ Faculty of Mathematics and Computer Science, FernUniversität in Hagen, IZ,
Universitätsstr. 1, 58084, Hagen, Germany

² Université Côte d'Azur, Inria, CNRS, I3S, Sophia Antipolis, France

³ Dept. Math & Stats, Dalhousie University, Halifax, Canada

EXTENDED ABSTRACT

We consider two variants of *orthogonal colouring games* on graphs. In these games, two players alternate colouring vertices (from a choice of $m \in \mathbb{N}$ colours) of a pair of isomorphic graphs while respecting the properness and the orthogonality of the colouring. In the *normal* play variant, the player who is unable to move loses. In the *scoring* variant, each player aims to maximise her *score*, which is the number of coloured vertices in the copy of the graph she owns.

We prove that, given an instance with a partial colouring, both the normal play and the scoring variant of the game are PSPACE-complete. The main result of this paper is that the second player has a strategy to force a draw in the scoring variant for any $m \in \mathbb{N}$ for graphs that admit a *strictly matched involution*. We give a structural characterisation of such graphs and bounds for the number of such graphs. However, we prove that it is NP-complete to recognize graphs that admit a strictly matched involution.

1 Introduction

In this paper, we consider two game-theoretic variants of orthogonal graph colouring. Recall that a partial colouring of a graph $G = (V, E)$ is *proper* if any two adjacent coloured vertices have distinct colours. Two partial colourings c_A and c_B of G are *orthogonal* if, for any two vertices $v, w \in V$ that are coloured in both c_A and c_B , the ordered pair of colours of v differs from the ordered pair of the colours of w , i.e., $(c_A(v), c_B(v)) \neq (c_A(w), c_B(w))$. Both games are played on two isomorphic copies G_A and G_B of a given graph G by two players, Alice and Bob. We identify the vertices of G_A and G_B with their preimages in G . Initially, all vertices of the graphs are uncoloured. Alternately, the players choose either G_A or G_B and colour one of its uncoloured vertices with a colour from the set $\{1, \dots, m\}$, thus creating partial colourings c_A and c_B of G such that the properness and the orthogonality of the partial colourings are not violated. The game ends when the players are unable to move. We call the general framework of this type of game the *orthogonal colouring game*. The winning conventions of the two variants of the game differ.

In the *normal play variant* $NorMOC_m(G)$ of the orthogonal colouring game, the player who is unable to move loses. The other player wins. So there is no draw.

In the *scoring variant* $MOC_m(G)$ of the orthogonal colouring game, Alice owns G_A and Bob owns G_B . The *score* of a player is the number of coloured vertices in their copy of G . When no more vertices can be coloured, the player with the higher score wins. If the scores are equal, there is a draw. The majority of the results of this paper are for the scoring variant.

As examples, Alice wins in $MOC_1(2K_1)$ and Bob in $MOC_2(C_4)$. As will be seen later in section 2, there are examples where the result of the scoring variant is a draw.

Motivation and Related Work. The game $MOC_m(G)$ emanates from the overlap of two lines of research: combinatorial and scoring games (specifically, colouring games) and orthogonality of Latin squares or, more generally, of colourings of graphs.

¹The full versions of this paper can be found at: hal.inria.fr/hal-02017462 and hal.inria.fr/hal-02053265.

Combinatorial games have been vastly studied (*e.g.*, [1, 7]), in particular in graphs, *e.g.*, [4, 6]. In general, the loser is the first player who cannot move, called the *normal play* convention. Note that a drawing strategy for the second player in the scoring variant of the orthogonal colouring game is a winning strategy for the second player in the normal play convention.

The colouring game on graphs in the normal play convention, which was introduced as the ACHIEVEMENT game in [11] and called the PROPER k -COLOURING game in [5], is closely related to the two variants of the orthogonal colouring game on graphs. In the PROPER k -COLOURING game, two players take turns colouring the vertices of a graph, while maintaining that the colouring is proper. In [5], it was shown that this game is PSPACE-complete when $k \in \mathbb{N}^*$ is the number of colours (even if k is a fixed constant), and an initial partial colouring is given. For $k = 1$ colour, the PROPER k -COLOURING game is the well-studied game NODE KAYLES. For specific classes of graphs, it is known which player wins the game NODE KAYLES, *e.g.*, for paths and cycles a complete characterisation was given in [7]. In [11], the winner was characterized in the PROPER k -COLOURING game played with $k = 2$ colours on paths and cycles, and played with any number k of colours on the Petersen graph.

More recently, there has been the development of a theory of **scoring games** [13, 14, 15] where the winner is the one with the greater score. Another type of scoring games, sometimes also called *maker-breaker games*, are based on the interplay of minimising versus maximising a score. Here, game-theoretic graph parameters are motivated by trying to get good approximations to graph parameters that are hard to calculate, *e.g.*, chromatic number [8] and domination number [12]. Typically, two players choose vertices (or edges or other sub-objects) without violating a given property (*e.g.*, independence). The score is the number of vertices chosen where one player wants to maximise the number and the other to minimise it.

Orthogonal colourings of graphs, *i.e.*, proper colourings of two isomorphic copies G_A and G_B of a graph respecting the orthogonality condition, have been studied too (*e.g.*, [2, 3, 10]). In [10], they studied the parameters $O_\chi(G)$ and $O_{\chi_k}(G)$ which are the minimum number of colours in any pair of orthogonal colourings of G , respectively, required such that there exist k mutually orthogonal colourings of G . Precisely, the graph versions of combinatorial objects associated with orthogonality such as Latin squares and Latin rectangles, were studied in [3].

Orthogonal Latin squares are natural combinatorial objects where there are two ‘boards’ and these form the basis of a specific orthogonal colouring game played on Latin squares.

Recall (see Brualdi [9]) that an $n \times n$ square, partially filled with entries taken from $\{1, 2, \dots, n\}$, has the *Latin property* if each row and column does not contain any repeated entries. A fully filled $n \times n$ square is a *Latin square* if each entry is an integer between 1 and n (inclusive) and each row and each column contains all n integers, which implies that the square has the Latin property. For a (partially filled) $n \times n$ square, X , let $c_X(i, j)$ be the (i, j) entry and \emptyset if (i, j) is unfilled. Let A and B be (partially filled) $n \times n$ squares. Then A and B are *orthogonal* if in the list $((c_A(i, j), c_B(i, j)))_{1 \leq i \leq n, 1 \leq j \leq n}$, every ordered pair of integers occurs at most once.

A Latin square of order n can be regarded as a proper colouring of the cartesian product of K_n with itself. Thus, the concept of orthogonal Latin squares translates to graph colourings and the orthogonal colouring game played on Latin squares is equivalent to $MOC_m(K_n \square K_n)$.

2 Our Results

All graphs we consider are simple and undirected. We first consider the complexity of the two variants of the game when a partial colouring is given as part of the input. Precisely:

Theorem 1. *Given an instance $NorMOC_m(G)$ of the orthogonal colouring game that includes a partial colouring, the problem of determining the outcome of $NorMOC_m(G)$ under optimal play is PSPACE-complete for all $m \geq 1$.*

Theorem 2. *Given an instance $MOC_m(G)$ of the orthogonal colouring game that includes a partial colouring, the problem of determining the outcome of $MOC_m(G)$ under optimal play is PSPACE-complete for all $m \geq 3$.*

Then we prove that for a special class of graphs, graphs admitting a *strictly matched involution*, the second player, Bob, can achieve at least a draw in the scoring variant.

This class of graphs includes many special cases where the game is to create combinatorial objects such as orthogonal Latin rectangles, double diagonal Latin squares, Latin squares, and sudoku squares. Precisely, recall that, for a graph $G = (V, E)$, an *automorphism* is a bijective mapping $\sigma : V \rightarrow V$ with the property that $\forall v, w \in V : (vw \in E \iff \sigma(v)\sigma(w) \in E)$. An *involution* of G is an automorphism σ of G with the property $\forall v \in V : (\sigma \circ \sigma)(v) = v$. We define an involution of G to be *strictly matched* if

(SI 1) the set $F \subseteq V$ of fixed points of σ (i.e., $F = \{v \in V \mid \sigma(v) = v\}$) induces a complete graph (i.e., for every $v, w \in F$ with $v \neq w$ we have $vw \in E$) and

(SI 2) for every $v \in V \setminus F$, we have the (matching) edge $v\sigma(v) \in E$.

If, for a graph G , there exists a strictly matched involution, we say that G admits a strictly matched involution.

Let G_1 and G_2 be the two copies of $G = (V, E)$ and let σ be a strictly matched involution of G . For $k \in \{1, 2\}$, we denote by $c_k(v)$ the colour of the vertex $v \in V$ in G_k . The strategy of the second player, Bob, is to copy (in a certain sense) Alice's moves in the other copy of the graph. Copying the symbols using the same positions would, in many cases, not be feasible because of orthogonality. Therefore, Bob couples the vertices of a graph with its image under σ of the other graph. Bob always uses the same colour as Alice just previously used.

For $c \in \{c_1, c_2\}$ we define \bar{c} to be the other partial colouring from $\{c_1, c_2\}$ distinct from c .

Consider the case that Alice assigns $c(v) := s$ for some $c \in \{c_1, c_2\}$, some $v \in V$, and some colour $s \in [m]$. Then, the copying strategy of Bob consists of assigning $\bar{c}(\sigma(v)) := s$. We prove that Bob will force a draw with this strategy.

Theorem 3. *Let G be a graph that admits a strictly matched involution and $m \in \mathbb{N}$. Then, the second player has a strategy guaranteeing a draw in the game $MOC_m(G)$.*

We first give an explicit characterization of all graphs G that admit a strictly matched involution. We then use this to give an explicit construction for any of these graphs.

Theorem 4. *A graph G admits a strictly matched involution if and only if its vertex set V can be partitioned into a clique C and a set inducing a graph that has a perfect matching M such that:*

- for any two edges $vw, xy \in M$, the graph induced by v, w, x, y is isomorphic to a $2K_2$, a C_4 or a K_4 ;
- for any edge $vw \in M$ and any vertex $z \in C$, the graph induced by the vertices v, w, z is isomorphic to a $K_1 \cup K_2$ or a K_3 .

Corollary 5. *Any graph G on n vertices admitting a strictly matched involution has a partition of its vertex set into three (possibly empty) vertex subsets inducing a clique C of size $n - 2k$ and two isomorphic graphs H and H' , each of size k , for some $k \in \mathbb{N}$ with $0 \leq k \leq \lfloor \frac{n}{2} \rfloor$, respectively. Moreover,*

- for any pair (v, v') of corresponding vertices $v \in V(H)$ and $v' \in V(H')$ and any vertex $w \in C$, either both vw and $v'w$ exist or none of them;
- for any pair (v, v') of corresponding vertices $v \in V(H)$ and $v' \in V(H')$, we have the existence of the matching edge $vv' \in E(G)$;
- for any two pairs (v, v') and (w, w') of corresponding vertices with $v, w \in V(H)$ and $v', w' \in V(H')$, either both vw' and $v'w$ exist or none of them.

According to Corollary 5, we can generate every graph on n vertices admitting a strictly matched involution if we fix some integer $k \leq \frac{n}{2}$ and take two copies of an arbitrary graph on k vertices which are matched by an isomorphism and add possible edges according to the rules given implicitly in Theorem 4 and explicitly in Corollary 5. Note that this construction may create isomorphic and even identical graphs. However, it gives us an upper bound for the number of such graphs. Before discussing the counting of such graphs, we prove that this class of graphs is nontrivial, namely that recognizing such graphs is an NP-complete problem.

Theorem 6. *The problem of deciding whether a graph G admits a strictly matched involution is NP-complete.*

Let $g(n)$ be the number of isomorphism classes of graphs on n vertices and $A(n)$ be the number of isomorphism classes of graphs admitting a strictly matched involution on n vertices.

Theorem 7. $A(n) = O\left(c(n)\sqrt{g(n)}\right)$ with $\log_2(c(n)) = o\left(\log_2 \sqrt[3]{g(n)}\right)$.

Theorem 8. $A(n) = \Omega\left(d(n)\sqrt[4]{g(n)}\right)$ with $\log_2\left(\frac{1}{d(n)}\right) = o\left(\log_2 \sqrt[4]{g(n)}\right)$.

Finally, we finish with some results on when the game is a draw. Specifically, first we note that, if m is large enough, both players have a strategy to force a draw. More interestingly, we show that there exist graphs that admit a strictly matched involution where the optimal result for both players is a draw for small values of m ($m = 1$).

Lemma 9. *For any graph G and all $m \in \mathbb{N}$ with $m \geq \Delta(G) + \alpha(G)$, both players have a strategy to draw in the $MOC_m(G)$ game.*

Lemma 10. *For all $n \in \mathbb{N}$, both players have a strategy to guarantee a draw in the $MOC_1(K_n \square K_n)$ game.*

Further Work. It would be interesting to know when is there a winning strategy for the second player for graphs admitting a strictly matched involution. In terms of complexity, what is the complexity of both variants when no partial colouring is given initially? Determining the complexity of the scoring variant of the orthogonal colouring game when a partial colouring is given for $m = 1$ ($m = 2$ respectively) colours is of interest as well.

References

- [1] M. H. Albert, R. J. Nowakowski and D. Wolfe, *Lessons in Play*, A.K. Peters/CRC Press, 2007.
- [2] D. Archdeacon, J. Dinitz, F. Harary. Orthogonal edge colorings of graphs, in: *Proceedings of the Sixteenth Southeastern International Conference on Combinatorics, Graph Theory and Computing*, 47:49–67, 1985.
- [3] S. C. Ballif. Upper bounds on sets of orthogonal colorings of graphs. *Discrete Math.* **313**:2195–2205, 2013.
- [4] L. Beaudou and E. Duchêne and S. Gravier, A survey about Solitaire Clobber, *Games of No Chance 4*, pp. 13–40 Cambridge University Press, 2015.
- [5] G. Beaulieu, K. Burke, and E. Duchêne, Impartial coloring games, *Theor. Comp. Sci.* 485:49–60, 2013.
- [6] R. A. Beeler, Tic-Tac-Toe on graphs, *Australasian J. of Combinatorics*, 72(1):106–112, 2018.
- [7] E. Berlekamp, J. H. Conway, and R. K. Guy, *Winning ways for your mathematical plays*, Vol. 1. A K Peters Ltd., 2nd edition, 2001.
- [8] Bodlaender, H. L., *On the complexity of some coloring games*, *Int. J. Found. Comp. Sci.* 2:133–147, 1991
- [9] R. Brualdi, *Introductory Combinatorics*, Pearson education Ltd., 5th edition, 2010
- [10] Y. Caro, R. Yuster. Orthogonal colorings of graphs, *Elec. J. Combin.* 6(1), 1999. Research paper 5, 14pp.
- [11] F. Harary and Z. Tuza, Two graph-colouring games, *Bull. Austral. Math. Soc.* 48:141–149, 1993
- [12] M. A. Henning and D. F. Rall. Progress towards the total domination game 2/3-conjecture. *Discrete Math.*, 339:2620–2627, 2016
- [13] U. Larsson, R. J. Nowakowski, J. P. Neto, C. P. Santos, Guaranteed Scoring Games, *Elec. J. Combin.*, 23, 2016. Paper 3.27
- [14] U. Larsson, R. J. Nowakowski, C. P. Santos, Game comparison through play, *Theor. Comp. Sci.*, 725:52–63, 2017.
- [15] U. Larsson, R. J. Nowakowski, C. P. Santos, Scoring games: the state of play. In U. Larsson, editor, *Games of No Chance 5*, volume 70 of *Mathematical Sciences Research Publications*, pp. 89–111. Cambridge Univ. Press, 2019.

IB- and MB-homogeneous graphs

Andrés Aranda

Institut für Algebra, Technische Universität Dresden, Germany

EXTENDED ABSTRACT

A countable L -structure M is *ultrahomogeneous* if every isomorphism between finite induced substructures is restriction of an automorphism of M . Under mild conditions for the language, this implies that the automorphism group of M is *oligomorphic*, meaning that the coordinatewise action of $\text{Aut}(M)$ on M^n has only finitely many orbits for all $n \in \mathbb{N}$. Ultrahomogeneity is then equivalent to elimination of quantifiers, which implies ω -categoricity (see [5] for details). These facts make ultrahomogeneous structures interesting from the points of view of group theory, model theory, and combinatorics.

The notion of *homomorphism-homogeneity* was introduced by Cameron and Nešetřil in [2] as a variation on ultrahomogeneity, where we require any homomorphism between finite substructures of M to be restriction of an endomorphism of M . Shortly afterwards, Lockett and Truss [7] introduced finer distinctions in the class of homomorphism-homogeneous L -structures. The idea is to fix the types of finite homomorphism and endomorphism.

In total, 18 *morphism-extension classes* were introduced in that paper. Their properties are abbreviated by a pair of letters XY , where $X \in \{I, M, H\}$ and $Y \in \{H, I, A, E, B, M\}$. These symbols stand for Isomorphism, Monomorphism, Homomorphism for X ; and Endomorphism (H), Self-embedding (I), Automorphism, Epimorphism, Bimorphism, and Monomorphism for Y . A structure is XY -homogeneous if every finite X -morphism is restriction of an endomorphism of type Y . The classes of homomorphism-homogeneity can be partially ordered by inclusion as in Figure 1 below.

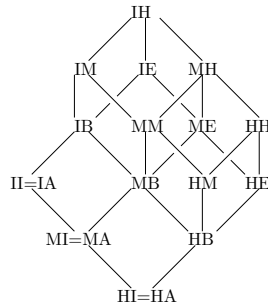

Figure 1: Morphism-extension classes of countable L -structures partially ordered by \subseteq .

In the case of graphs, this partial order reduces to the ones presented in Figure 2.

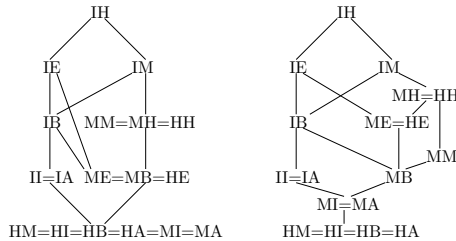

Figure 2: Morphism-extension classes of countable graphs (R) and connected graphs (L).

The classification of countable ultrahomogeneous graphs was completed in the 80s with the Lachlan-Woodrow theorem [6]. There are only countably many countable ultrahomogeneous

graphs. Namely, they are unions of equipotent complete graphs, the Rado graph, the universal homogeneous K_n -free graphs, and their complements.

Homomorphism-homogeneous graphs are much more abundant. It is known, for example, that any countable graph that contains the Rado graph as a spanning subgraph is homomorphism-homogeneous [2], and so there are uncountably many pairwise non-isomorphic countable homomorphism-homogeneous graphs. One should ask for a coarser classification.

Fraïssé theorems take the following form: first, if M is an XY -homogeneous L -structure, then its age (that is, the class of finite L -structures embeddable into M) is countable up to isomorphism, hereditary, and satisfies the joint embedding property and one or two amalgamation properties. Then a converse is proved: from a countable (up to isomorphism) hereditary class \mathcal{C} of finite structures with the joint embedding property and one or two amalgamation properties, it is possible to construct a *limit*, that is, a countable XY -homogeneous structure whose age is \mathcal{C} . Finally, there is a statement about the uniqueness of the limit. In the classical Fraïssé theorem, limits are unique up to isomorphism, but in its XY -analogues limits are unique up to coarser equivalence relations, see [3].

The ideal level of coarseness for a classification of XY -homogeneous structures is given by the corresponding analogue of Fraïssé's theorem. Until recently, only a few of the Fraïssé theorems were known, so even the coarseness of the ideal classification was not known. At the time of this writing, 12 of the 18 Fraïssé theorems were proved using more or less uniform methods by Coleman [3], and the rest have been proved by the present autor, but not published yet.

Because of the reasons exposed above (dearth of tools, over-abundance of structures), the classification of homomorphism-homogeneous graphs is still open. In this abstract, we present some recent advances in that direction. Namely, we present a classification of MB-homogeneous graphs up to bimorphism-equivalence and a theorem stating that an IB-homogeneous graph is either ultrahomogeneous or MB-homogeneous.

1 MB-homogeneous graphs

The Fraïssé theorem for MB-homogeneous structures establishes uniqueness of the limit up to bi-equivalence. Two structures are bi-equivalent if they have the same age and every finite isomorphism between them can be extended to a bimorphism. However, it is known that there exist uncountably many classes of MB-homogeneous graphs under this relation, so a classification to that level of precision seems unlikely (Theorem 3.20 of [4]). The next best thing is a classification up to bimorphism-equivalence (two graphs are bimorphism-equivalent if each is a spanning subgraph of the other), which still carries some structural information, as we will see.

The key to the classification of MB-homogeneous graphs is the following theorem.

Theorem 1 (Aranda-Hartman '18 [1]) *Let G be a countably infinite connected HH-homogeneous graph, and suppose that G does not contain a copy of the Rado graph as a spanning subgraph. Then G has finite independence number.*

A countable graph G has property (Δ) if for all finite $X \subset G$ there exists $y \in G$ such that xy is an edge for all $x \in X$. We say that G satisfies (\cdot) if the complement of G has (Δ) . It is easy to prove that property (Δ) is equivalent to containing the Rado graph as a spanning subgraph, and that a countable graph with (Δ) and (\cdot) is bimorphism-equivalent to the Rado graph. One can also easily verify that any graph that is bimorphism-equivalent to the Rado graph is MB-homogeneous. In fact, these observations almost complete the classification of MB-homogeneous graphs.

Theorem 2 (Coleman-Evans-Gray [4]) *If G is an MB-homogeneous graph then so is its complement \bar{G} .*

From Figure 2, we know that all MB-homogeneous graphs are HH-homogeneous, and so any disconnected MB-homogeneous graph is a disjoint union of equipotent cliques. It is also known that in a countable connected HH-homogeneous graph every vertex has infinite degree (this follows, for example, from the proof of Proposition 1.1. of [2]). Now, if G is a countable MB-homogeneous graph and G is not complete or empty, then one can prove quite quickly that it must have infinitely many connected components, and each component must be infinite. Using the surjectivity of bimorphisms, we can copy the argument from HH-homogeneous graphs and prove that every vertex has also infinite co-degree. Thus, we know

Corollary 3 *If G is MB-homogeneous and neither complete nor empty, then G is either connected or isomorphic to $I_\omega[K_\omega]$. Moreover, every vertex in G has infinite degree and codegree.*

From this it takes only a few steps to verify that whenever a finite subset of an MB-homogeneous graph has a *co-cone* (that is, a common non-neighbour), then there is an infinite independent set of co-cones over that set. This greatly reduces the possibilities, since by Theorem 1 this means that all non-complete MB-homogeneous graphs satisfy (Δ) . Thus we prove

Theorem 4 (Aranda-Hartman '18 [1]) *If G is a countable MB-homogeneous graph, then it is bimorphism-equivalent to one of the following or its complement:*

1. A complete graph K_ω ,
2. a countable union of countable cliques $I_\omega[K_\omega]$, or
3. the Rado graph \mathcal{R} .

2 IB-homogeneous graphs

In some recent unpublished work, the present author has proved an analogue of the Fraïssé theorem for IB-homogeneous structures. The theorem is somewhat different from all such theorems known until now, because it establishes homogeneity with respect not to *all*, say isomorphisms or monomorphisms or homomorphisms, but with respect to *some* select monomorphisms (meaning that any monomorphism from that chosen family, which is required to contain all isomorphisms, can be extended to a bimorphism).

Theorem 5 (Aranda 20+) *Suppose that M is an IB-homogeneous L -structure, and let \mathcal{F} be the function assigning to each pair of isomorphism types of finite induced substructures A, B of M the set $\text{Mon}(A, B)_M$ of all monomorphisms from A to B that are restrictions of bimorphisms of M . Then $\text{Age}(M)$ is an hereditary class of finite structures containing only countably many isomorphism types, with the joint embedding property, and with the following amalgamation properties:*

1. For all $A, B_0, B_1 \in \text{Age}(M)$ and $f_0 \in \mathcal{F}(A, B_0)$, $e_0 : A \rightarrow B_0$, where e_0 is an embedding, there exists $C \in \text{Age}(M)$, $f_1 \in \mathcal{F}(B_1, C)$, and an embedding $e_1 : B_0 \rightarrow C$ such that $e_1 \circ f_0 = f_1 \circ e_0$, and
2. For all $A, B_0, B_1 \in \text{Age}(M)$ and $f_0 \in \mathcal{F}^-(A, B_0)$, $e_0 : A \rightarrow B_0$, where e_0 is an embedding, there exists $C \in \text{Age}(M)$, $f_1 \in \mathcal{F}^-(B_1, C)$, and an embedding $e_1 : B_0 \rightarrow C$ such that $e_1 \circ f_0 = f_1 \circ e_0$.

In the second item, $\mathcal{F}^-(A, B)$ denotes the set of left inverses of functions in $\mathcal{F}(B, A)$.

Conversely, if \mathcal{C} is a hereditary class of finite structures that is countable modulo isomorphism, has the joint embedding property and the amalgamation properties above with respect

to a family \mathcal{F} of monomorphisms that includes all embeddings and is closed under restriction and composition, then there exists a countable IB-homogeneous structure M with $\text{Age}(M) = \mathcal{C}$ such that all functions in \mathcal{F} are restrictions of bimorphisms of M .

One amalgamation property ensures the possibility of extending some monomorphisms, while the other, intended to ensure the surjectivity of an extension, can also be interpreted as the possibility of extending the left inverses of the same monomorphisms to global bijective functions that preserve, in the case of graphs, non-adjacency.

Observe now that any bimorphism that preserves non-adjacency is actually an automorphism. If G has proper bimorphisms (bimorphisms that map a nonedge to an edge), then the monomorphism that maps a nonedge to an edge is a restriction of a bimorphism. For concreteness, let's call this monomorphism m . We see at once that if G is IB-homogeneous and has no proper bimorphisms, then G is ultrahomogeneous. The last two crucial lemmas are as follows.

Lemma 6 *If G is an IB-homogeneous graph, then so is its complement \bar{G} , and if m is restriction of a bimorphism of G , then it is also restriction of a bimorphism of \bar{G} .*

Lemma 7 *If G is an IB-homogeneous graph and m is restriction of a bimorphism of G , then every finite subset X is image under a bimorphism of an independent set and can be mapped by a bimorphism to a clique.*

The last lemma tells us that all IB-homogeneous graphs in which m is restriction of a bimorphism have infinite independence number, and so satisfy (Δ) . Mixed with Lemma 6, we obtain that their complements must also satisfy (Δ) , so they are MB-homogeneous.

Theorem 8 (Aranda '20+) *If G is an IB-homogeneous graph then G is ultrahomogeneous or MB-homogeneous.*

3 Acknowledgements

Research funded by the ERC under the European Union's Horizon 2020 Research and Innovation Programme (grant agreement No. 681988, CSP-Infinity).

References

- [1] A. Aranda, D. Hartman. The independence number of HH-homogeneous graphs and a classification of MB-homogeneous graphs. To appear in **European J. Combin.**. arXiv preprint arXiv:1902.03126.
- [2] P.J. Cameron, J. Nešetřil. Homomorphism-homogeneous relational structures. In **Combin. Probab. Comput.** 15:91–103, 2006.
- [3] T. D. H Coleman. Two Fraïssé-style theorems for homomorphism-homogeneous relational structures. arXiv preprint arXiv:1812.01934.
- [4] T. D. H Coleman, D. M. Evans, R. D. Gray. Permutation monoids and MB-homogeneity for graphs and relational structures. In **European J. Combin.**, 78:163–189, 2019.
- [5] H. D. Macpherson. A survey of homogeneous structures. In **Discrete Mathematics**, vol. 311, 15:1599–1634, 2011.
- [6] A. H. Lachlan, R. E. Woodrow. Countable ultrahomogeneous undirected graphs. In **Trans. Amer. Math. Soc.**, 51–94, 1980.
- [7] D.C. Lockett, J. K. Truss. Some more notions of homomorphism–homogeneity. In **Discrete Math.**, 336:69–79, 2014.

Eternal domination on digraphs and orientations of graphs

Guillaume Bagan, Hamamache Kheddouci, and Alice Joffard

LIRIS, University of Lyon, France

EXTENDED ABSTRACT

We study the eternal domination number and the m-eternal domination number on digraphs. We generalize known results on graphs to digraphs. We also consider the problem "oriented (m-)eternal domination", consisting in finding an orientation of a graph that minimizes its eternal domination number. We prove that computing the oriented eternal domination number is NP-hard and characterize the graphs for which its value is 2. We also study these two parameters on trees, cycles, cliques, bicliques and different kinds of grids.

1 Introduction

The problem of eternal domination on undirected graphs, while being a rather recent problem, has been widely studied (see [5] for a survey). It has initially been motivated by problems in military defense.

The eternal domination on a graph G can be seen as an infinite game between two players: the *defender* and the *attacker*. First, the defender chooses a set D_0 of k vertices, with k fixed, called *guards*. At turn i , the attacker chooses a vertex r_i called *attack* in $V \setminus D_{i-1}$ and the defender must *defend* the attack by moving to v_i exactly one guard along one edge, from a vertex v_i adjacent to r_i . The new guards configuration is $D_i = D_{i-1} \cup \{r_i\} \setminus \{v_i\}$. The defender wins the game if it can defend any infinite sequence of attacks. The *eternal domination number*, denoted by $\gamma^\infty(G)$, is the minimum number of guards necessary for the defender to win. An *eternal dominating set* is a set that can initially be chosen by the defender in a winning strategy.

The m-eternal domination is similar to the eternal domination but the defender is authorized to move as many guards as it wants among the k guards at each turn. The m-eternal domination number is denoted by $\gamma_m^\infty(G)$.

In general graphs, the two following results compare the values of both the eternal domination number and the m-eternal domination number to the values of other well-known graph parameters.

Theorem 1 [2, 3, 4] *For every graph G , we have*

$$\gamma(G) \leq \gamma_m^\infty(G) \leq \alpha(G) \leq \gamma^\infty(G) \leq \binom{\alpha(G) + 1}{2}$$

where $\gamma(G)$ is the domination number of G , and $\alpha(G)$ is the independence set number of G .

Theorem 2 [2] *For every graph G , we have*

$$\gamma^\infty(G) \leq \theta(G)$$

where $\theta(G)$ is the clique covering number of G .

The values of γ^∞ and γ_m^∞ have been studied for many graph classes and, in particular, grids.

To our knowledge, the eternal domination problem has only been studied on undirected graphs. In this paper, we consider eternal domination on directed graphs where the guards must follow the direction of the arcs, both when they defend a vertex and when they move to another vertex. Additionally, as it has been done for many digraph parameters such as the domination number or the maximum outgoing degree, we consider the problem consisting in orienting an undirected graph to minimize γ^∞ or γ_m^∞ .

2 Eternal domination on digraphs

The main result of this section is the generalization of Theorem 1 to directed graphs. We define the parameter $\alpha(D)$ of a digraph D as the order of the greatest induced acyclic subgraph of D .

Notice that this parameter is a generalization of $\alpha(G)$ for graphs since $\alpha(G) = \alpha(\overleftrightarrow{G})$ for any graph G where \overleftrightarrow{G} denotes the directed graph obtained by replacing each edge uv of G by two arcs uv and vu . The analogue of Theorem 1 gives:

Theorem 3 *For every digraph D , we have*

$$\gamma(D) \leq \gamma_m^\infty(D) \leq \alpha(D) \leq \gamma^\infty(D) \leq \binom{\alpha(D) + 1}{2}.$$

3 Eternal domination on orientations of graphs

3.1 Definitions

We now orient undirected graphs in order to minimize their eternal or m-eternal domination numbers. An *orientation* of an undirected graph G is an assignment of exactly one direction to each edge of G . This leads to the introduction of three new parameters for undirected graphs:

$$\overrightarrow{\gamma}^\infty(G) = \min\{\gamma^\infty(D) : D \text{ is an orientation of } G\},$$

$$\overrightarrow{\gamma}_m^\infty(G) = \min\{\gamma_m^\infty(D) : D \text{ is an orientation of } G\},$$

$$\overrightarrow{\alpha}(G) = \min\{\alpha(D) : D \text{ is an orientation of } G\}.$$

3.2 General results

We first give general results for undirected graphs, such as the inequality linking $\overrightarrow{\alpha}(G)$ to $\overrightarrow{\gamma}^\infty(G)$.

Lemma 4 $\overrightarrow{\alpha}(G) \leq \overrightarrow{\gamma}^\infty(G)$.

Let G be an undirected graph. We define $C(G)$ by starting from G , adding one vertex per edge of G and connecting each new vertex to the extremities of the associated edge. This definition allows us to present the following result:

Lemma 5 *For every undirected graph G with m edges, we have:*

- $\overrightarrow{\gamma}^\infty(C(G)) = \gamma^\infty(G) + m$
- $\overrightarrow{\alpha}(C(G)) = \alpha(G) + m$.

The consequences of this lemma are particularly interesting, leading to complexity results:

Corollary 6 *For every $k > 0$, there exists a graph G such that $\overrightarrow{\gamma}^\infty(G) \geq \overrightarrow{\alpha}(G) + k$.*

Corollary 7 *Computing $\overrightarrow{\gamma}^\infty(G)$ is NP-hard.*

Corollary 8 *Computing $\overrightarrow{\alpha}(G)$ is NP-hard.*

3.3 Results on some classes of graphs

We study the value of $\overrightarrow{\gamma}^\infty$ and $\overrightarrow{\gamma}_m^\infty$ for particular classes of graphs. The first result is a full characterization of the graphs for which $\overrightarrow{\gamma}^\infty$ and $\overrightarrow{\gamma}_m^\infty$ are maximal.

Theorem 9 *Let G be a graph with order n . Then, the following are equivalent:*

- $\overrightarrow{\gamma}^\infty(G) = n$
- $\overrightarrow{\gamma}_m^\infty(G) = n$
- G is a forest.

Studying the value of $\overrightarrow{\gamma}_m^\infty$ for complete graphs led to a characterization of the graphs G for which $\overrightarrow{\gamma}_m^\infty(G) = 2$.

Theorem 10 *Let G be a graph of order $n \geq 3$. Then, $\overrightarrow{\gamma}_m^\infty(G) = 2$ iff either:*

- $n = 2k$ and G is a complete graph from which at most k disjoint edges are removed
- $n = 2k + 1$ and G is a complete graph from which at most $k - 1$ disjoint edges are removed.

The exact value of $\overrightarrow{\gamma}^\infty$ for complete graphs seems hard to find and we could only obtain bounds by combining Theorem 3 and a result from Erdős and Moser concerning $\overrightarrow{\alpha}$.

Theorem 11 $\lceil \log_2 n \rceil + 1 \leq \overrightarrow{\gamma}^\infty(K_n) \leq (2^{\lceil \log_2 n \rceil + 2})$.

The case of bicliques, on the other hand, has been fully covered for both parameters.

Theorem 12 $\overrightarrow{\gamma}^\infty(K_{n,m}) = \max\{n, m\} + 1$ for every $n, m \geq 1$.

Theorem 13 $\overrightarrow{\gamma}_m^\infty(K_{2,2}) = 2$
 $\overrightarrow{\gamma}_m^\infty(K_{2,3}) = \overrightarrow{\gamma}_m^\infty(K_{3,3}) = 3$
 $\overrightarrow{\gamma}_m^\infty(K_{n,m}) = 4$ for every $n \geq 2$ and $m \geq 4$.

We intensively studied the case of grids, considering both parameters on square grids, toric grids, toric king grids and toric hypergrids. The study of $\overrightarrow{\gamma}^\infty$ on square grids leads to the following result:

Theorem 14

$$\left\lceil \frac{2mn}{3} \right\rceil \leq \overrightarrow{\gamma}^\infty(P_n \square P_m) \leq \left\lceil \frac{7mn + 2m + 2n}{9} \right\rceil.$$

When m and n are both multiples of 3, we have:

$$\overrightarrow{\gamma}^\infty(P_n \square P_m) \leq \frac{7mn}{9}.$$

For square grids of size $2 \times n$, $3 \times n$ and $4 \times n$, we have the exact value of $\overrightarrow{\gamma}^\infty$.

Theorem 15 *Let $n \geq 2$. Then, $\overrightarrow{\gamma}^\infty(P_2 \square P_n) = \lceil \frac{3n}{2} \rceil$,
 $\overrightarrow{\gamma}^\infty(P_3 \square P_n) = \lceil \frac{7n}{3} \rceil$,
 $\overrightarrow{\gamma}^\infty(P_4 \square P_n) = 3n$.*

4 Conjectures and open questions

We give here some future works and open questions.

We would like to find out if there is a natural parameter for digraphs that is an upper bound of γ^∞ , as the clique covering number is for graphs.

We could also give better bounds for $\overrightarrow{\gamma}^\infty$ on complete graphs, and in particular, determine if $\overrightarrow{\gamma}^\infty(K_n) = \overrightarrow{\alpha}(K_n)$ for any n .

The complexities of deciding whether $\overrightarrow{\gamma}_m^\infty \leq k$ in the general case and when k is fixed are still unknown.

We also conjecture that $\overrightarrow{\gamma}_m^\infty(D) \leq \lceil \frac{n}{2} \rceil$ for every strongly connected digraph D .

References

- [1] Klostermeyer, William F. Complexity of eternal security. In **Journal of Combinatorial Mathematics and Combinatorial Computing** 61:135, 2007.
- [2] Burger, AP and Cockayne, EJ and Grundlingh, WR and Mynhardt, CM and Van Vuuren, JH and Winterbach, W. Infinite order domination in graphs. In **Journal of Combinatorial Mathematics and Combinatorial Computing** 50:179–194, 2004.
- [3] Goddard, Wayne and Hedetniemi, Sandra M and Hedetniemi, Stephen T. Eternal security in graphs. In **Journal of Combinatorial Mathematics and Combinatorial Computing** 52:169–180, 2005.
- [4] William Klostermeyer and Gary MacGillivray. Eternal security in graphs of fixed independence number. In **Journal of Combinatorial Mathematics and Combinatorial Computing** 63:97, 2007.
- [5] Klostermeyer, William F and Mynhardt, C. M. Protecting a graph with mobile guards. In **Applicable Analysis and Discrete Mathematics**, 10:1–29, 2016.
- [6] Erdos, Paul and Moser, Leo. On the representation of directed graphs as unions of orderings. In **Math. Inst. Hung. Acad. Sci**, 9:125–132, 1964.

On identifying codes in line digraphs

Camino Balbuena ¹, Cristina Dalfó ², and Berenice Martínez-Barona ¹

¹ Departament d'Enginyeria Civil i Ambiental, Universitat Politècnica de Catalunya, Barcelona, Spain

² Departament de Matemàtica, Universitat de Lleida, Igualada (Barcelona), Catalonia, Spain

EXTENDED ABSTRACT

1 Description

We consider simple digraphs without loops or multiple edges. In the line digraph LD of a digraph D , each vertex represents an arc of D . Thus, the set of vertices of LD is $V(LD) = \{uv : (u, v) \in A(D)\}$; and a vertex uv is adjacent to a vertex wz if and only if $v = w$. For any integer $k \geq 1$, the k -iterated line digraph $L^k D$ is defined recursively by $L^k D = LL^{k-1} D$, where $L^0 D = D$.

A large known family of digraphs obtained with the line digraph technique is the family of Kautz digraphs. The *Kautz digraph* of degree d and diameter k is defined as the $(k - 1)$ -iterated line digraph of the symmetric complete digraph of $d + 1$ vertices K_{d+1} , that is, $K(d, k) \cong L^{k-1} K_{d+1}$.

For a given integer $\ell \geq 1$, a vertex subset C of the set of vertices $V(D)$ is a $(1, \leq \ell)$ -*identifying code* in the digraph D if it is a dominating set and for all distinct subsets $X, Y \subset V(D)$, with $1 \leq |X|, |Y| \leq \ell$, we have

$$N^-[X] \cap C \neq N^-[Y] \cap C. \quad (1)$$

A $(1, \leq 1)$ -identifying code is known as an *identifying code*.

In [3], Charon, Hudry and Lobstein proved that, given an oriented graph D and an integer k , the decision problem of the existence of a $(1, \leq 1)$ -identifying code of size at most k in D is NP-complete, even when we are restricted to strongly connected, oriented, and bipartite digraphs without cycles.

In [1], the authors studied the $(1, \leq \ell)$ -identifying codes in digraphs. They proved that if D is a digraph admitting a $(1, \leq \ell)$ -identifying code, then $\ell \leq \min\{d^-(u) + 1 \mid u \in V(D) \text{ and } d^+(u) \leq 1\}$ and gave some sufficient conditions for a digraph of minimum in-degree $\delta^- \geq 1$ to admit a $(1, \leq \ell)$ -identifying code for $\ell = \delta^-, \delta^- + 1$. They also gave in [2] an upper bound on ℓ for graphs and digraphs. In this work, we study $(1, \leq \ell)$ -identifying codes in line digraphs, where $\ell \geq 1$ is an integer.

2 Results

Line digraphs were characterized by Heuchenne's condition: A digraph D is a line digraph if and only if it has no multiple arcs, and for any pair of vertices u and v , either $N^-(u) \cap N^-(v) = \emptyset$ or $N^-(u) = N^-(v)$. Using this characterization we prove the next proposition.

Proposition 1 *The line digraph of a strongly connected digraph of order at least 3 admits an identifying code. \square*

In the following theorem, we give sufficient and necessary conditions for a line digraph to admit a $(1, \leq 2)$ -identifying code.

Theorem 2 *Let LD be a line digraph different from a 4-cycle and such that the vertices of in-degree 1 (if any) does not lay on a digon. Then, LD admits a $(1, \leq 2)$ -identifying code if and only if LD satisfies the following conditions:*

- (i) There are no 3-cycles with at least 2 vertices of in-degree 1;
- (ii) There do not exist four vertices x, x', y and y' such that $N^-(x) = \{y, y'\}$, $N^-(y') = \{x'\}$, and $x \in N^-(x') \cap N^-(y)$;
- (iii) There do not exist two vertices $x, y \in V(LD)$ such that $N^-(x) = \{y, y'\}$, $N^-(y) = \{x, x'\}$, and $N^-(x') \cap N^-(y') \neq \emptyset$.

Corollary 3 Let $L^k D$ be a k -iterated line digraph with minimum in-degree $\delta^- \geq 2$.

- (i) If $k \geq 2$, then $L^k D$ admits a $(1, \leq 2)$ -identifying code.
- (ii) If $k = 1$ and $\delta^- \geq 3$, then LD admits a $(1, \leq 2)$ -identifying code.

Corollary 4 For each $n \geq 3$, the Kautz digraph $K(n, 2) = LK_{n+1}$ admits a $(1, \leq 2)$ -identifying code.

By Corollary 3 (iii), the Kautz digraph $K(2, 2)$ is isomorphic to LK_3 . Then, the condition $k \geq 2$ in Corollary 3 (i) is necessary.

Proposition 5 Let LD be a line digraph with minimum in-degree $\delta^- \geq 2$, then LD does not admit a $(1, \leq 3)$ -identifying code.

Foucaud, Naserasr, et al. [4] characterized the digraphs that only admit as identifying code the whole set of vertices. As a consequence, if LD is a line digraph with minimum in-degree $\delta^- \geq 2$, then $\vec{\gamma}^{ID}(LD) \leq |V(LD)| - 1$, where $\vec{\gamma}^{ID}(D)$ denotes the minimum size of an identifying code of a digraph D . Next, we establish better upper bounds on $\vec{\gamma}^{ID}(LD)$.

For each vertex $v \in V(D)$, we denote $\omega^-(v) = \{(u, v) \in A(D)\}$ and $\omega^+(v) = \{(v, u) \in A(D)\}$.

Definition 6 Given a digraph D , a subset C of $A(D)$ is an arc-identifying code of D if C satisfies both conditions:

- an arc-dominating set of D , that is, for each arc $uv \in A(D)$, $(\{uv\} \cup \omega^-[u]) \cap C \neq \emptyset$, and
- an arc-separating set of D , that is, for each pair $uv, wz \in A(D)$ ($uv \neq wz$), $(\{uv\} \cup \omega^-[u]) \cap C \neq (\{wz\} \cup \omega^-[w]) \cap C$.

Hence, a line digraph LD admits a $(1, \leq \ell)$ -identifying code if and only if D admits a $(1, \leq \ell)$ -arc-identifying code. As a consequence, the minimum size of an identifying code of a digraph D , $\vec{\gamma}^{ID}(LD)$, is equivalent to the minimum size of an arc-identifying code of its line digraph LD .

Let D be a digraph. We denote $V_{\geq 2}^+(D) = \{v \in V(D) : d^+(v) \geq 2\}$, and $V_1^+(D) = \{v \in V(D) : d^+(v) = 1\}$. Hence, in particular, if D is a strongly connected digraph, $V(D) = V_1^+(D) \cup V_{\geq 2}^+(D)$.

Theorem 7 Let D be a strongly connected digraph with minimum in-degree $\delta^- \geq 2$. Then,

$$\vec{\gamma}^{ID}(LD) \geq |A(D)| - |V(D)|.$$

Theorem 8 Let D be a strongly connected digraph of order at least 3, and let $C \subseteq A(D)$. Then, C is an arc-identifying code of D if and only if C satisfies the following conditions:

- (i) For all $v \in V(D)$, $|\omega^+(v) \setminus C| \leq 1$, and if $|\omega^+(v) \setminus C| = 1$, then $\omega^-(v) \cap C \neq \emptyset$;
- (ii) For all $uv \in C$, if $vu \in C$ or $|\omega^+(v) \setminus C| = 1$, then $(\omega^-(v) \cup \omega^-(u)) \setminus \{uv, vu\} \cap C \neq \emptyset$.

Now we present an algorithm for constructing an arc-identifying code of a strongly connected oriented (that is, without digons) graph with minimum in-degree $\delta^- \geq 2$.

Algorithm 9 *Constructing an arc-identifying code C of a strongly connected digraph D with minimum in-degree $\delta^- \geq 2$ and without digons.*

- 1: Let $U^- := \{v \in V(D) : N^-(v) \subseteq V_1^+(D)\}$, $U := \emptyset$ and $C := \emptyset$
- 2: **while** $U^- \setminus U \neq \emptyset$ **do**
- 3: let $v \in U^- \setminus U$ and $f \in N^-(v)$
- 4: replace U by $U \cup \{v\}$ and C by $C \cup \{fv\}$
- 5: **end while**
- 6: let $X := V_1^+(D)$ and $Y := U^-$
- 7: let $xy \in A(D)$ such that $x \in V(D) \setminus X$ and $y \in V(D) \setminus Y$
- 8: replace Y by $Y \cup (N^+(x) \setminus \{y\})$, X by $X \cup \{x\}$ and C by $C \cup (\omega^+(x) \setminus \{xy\})$
- 9: **while** $Y \neq V(D)$ **do**
- 10: **while** $N^-(y) \setminus X \neq \emptyset$ **do**
- 11: let $t \in N^-(y) \setminus X$ and let $z \in N^+(t) \setminus \{y\}$
- 12: replace Y by $Y \cup (N^+(t) \setminus \{z\})$, X by $X \cup \{t\}$, C by $C \cup (\omega^+(t) \setminus \{tz\})$, t by x and z by y
- 13: **end while**
- 14: **if** $N^-(y) \setminus X = \emptyset$ **then**
- 15: choose an arc uv of D such that $v \notin Y$
- 16: replace Y by $Y \cup (N^+(u) \setminus \{v\})$, X by $X \cup \{u\}$, C by $C \cup (\omega^+(u) \setminus \{uv\})$, u by x and v by y
- 17: return to 3
- 18: **end if**
- 19: **end while**
- 20: **if** $Y = V(D)$ **then**
- 21: **while** $X \neq V(D)$ **do**
- 22: let $u \in V(D) \setminus X$ and let $v \in N^+(u)$
- 23: replace C by $C \cup (\omega^+(u) \setminus \{uv\})$, X by $X \cup \{u\}$
- 24: **end while**
- 25: **end if**
- 26: return C

Theorem 10 *Let D be an oriented and strongly connected graph with minimum in-degree $\delta^- \geq 2$. Then, Algorithm 9 produces a subset $C \subset A(D)$ with*

$$|C| = |A(D)| - |V(D)| + |\{v \in V(D) : N^-(v) \subseteq V_1^+(D)\}|,$$

satisfying the requirements of Theorem 8.

As a consequence of Theorems 7 and 10, we can conclude the following corollary.

Corollary 11 *Let D be a strongly connected oriented graph with minimum in-degree $\delta^- \geq 2$. Then, the following assertions hold.*

- (i) $\vec{\gamma}^{ID}(LD) = |A(D)| - |V(D)| + |\{v \in V(D) : N^-(v) \subseteq V_1^+(D)\}|$ if $\delta^+ = 1$;
- (ii) $\vec{\gamma}^{ID}(LD) = |A(D)| - |V(D)|$ if $\delta^+ \geq 2$.

Next, we also present a result for all Hamiltonian digraphs of minimum degree at least two, not necessarily oriented.

Theorem 12 *Let D be a Hamiltonian strongly connected digraph with minimum in-degree $\delta^- \geq 3$ and out-degree $\delta^+ \geq 2$. Then, $\gamma^{ID}(LD) = |A(D)| - |V(D)|$.*

Moreover, using Theorem 12 and the 1-factorization of Kautz digraphs obtained by Tvrdík [5], we conclude the following result.

Theorem 13 *The identifying number of a Kautz digraph $K(d, k)$ is $\gamma^{ID}(K(d, k)) = d^k - d^{k-2}$ for $d \geq 2$ and $k \geq 2$.*

References

- [1] C. Balbuena, C. Dalfó, B. Martínez-Barona. Sufficient conditions for a digraph to admit a $(1, \leq \ell)$ -identifying code. **Discuss. Math. Graph Theory**, 2019 (accepted). <http://arxiv.org/abs/1902.04913>.
- [2] C. Balbuena, C. Dalfó, B. Martínez-Barona. Characterizing identifying codes from the spectrum of a graph or digraph. **Linear Algebra Appl.**, 570:138–147, 2019.
- [3] I. Charon, O. Hudry, A. Lobstein. Identifying and locating-dominating codes: NP-completeness results for directed graphs. **IEEE Trans. Inform. Theory**, 48:2192–2200, 2002.
- [4] F. Foucaud, R. Naserasr, A. Parreau. Characterizing extremal digraphs for identifying codes and extremal cases of Bondy’s Theorem on induced subsets. **Graphs Combin.** 29:463–473, 2013.
- [5] P. Tvrdík. Necklaces and scalability of Kautz digraphs, **Proc. of the Sixth IEEE Symp. on Parallel and Distributed Processing**, Los Alamitos, 409–415, 1994.

Characterizing identifying codes from the spectrum of a graph or digraph

Camino Balbuena ¹, Cristina Dalfó ², and Berenice Martínez-Barona ¹

¹ Departament d'Enginyeria Civil i Ambiental, Universitat Politècnica de Catalunya, Barcelona, Spain

² Departament de Matemàtica, Universitat de Lleida, Igualada (Barcelona), Catalonia, Spain

EXTENDED ABSTRACT

1 Introduction

We consider simple digraphs (or directed graphs) without loops or multiple edges.

Given a vertex subset $U \subset V$, let $N^-[U] = \bigcup_{u \in U} N^-[u]$. For a given integer $\ell \geq 1$, a vertex subset $C \subset V$ is a $(1, \leq \ell)$ -*identifying code* in D when, for all distinct subsets $X, Y \subset V$, with $1 \leq |X|, |Y| \leq \ell$, the corresponding closed in-neighborhoods within the set C are different, that is

$$N^-[X] \cap C \neq N^-[Y] \cap C. \quad (1)$$

A $(1, \leq 1)$ -identifying code is referred to as an *identifying code*.

Laihonen [6] proved the following result for graphs.

Theorem 1 [6] *Let $k \geq 2$ be an integer.*

1. *If a k -regular graph has girth $g \geq 7$, then it admits a $(1, \leq k)$ -identifying code.*
2. *If a k -regular graph has girth $g \geq 5$, then it admits a $(1, \leq k - 1)$ -identifying code.*

Besides, Laihonen and Ranto [7] showed that if G is a connected graph with at least three vertices admitting a $(1, \leq \ell)$ -identifying code, then $\ell \leq \delta$, where δ is the minimum degree of G .

Regarding digraphs, the authors proved in [3] that every 1-in-regular digraph has a $(1, \leq 2)$ -identifying code if and only if its girth is at least 5. They also characterized the 2-in-regular digraphs having a $(1, \leq 2)$ -identifying code or a $(1, \leq 3)$ -identifying code. Moreover, they gave some sufficient conditions for a digraph of minimum in-degree $\delta^- \geq 2$ to admit a $(1, \leq \delta^-)$ -identifying code. As a corollary of this result, they proved that a graph of minimum degree $\delta \geq 2$ and girth at least 7 admits a $(1, \leq \delta)$ -identifying code.

Recall that if D admits a $(1, \leq \ell)$ -identifying code, then it admits a $(1, \leq \ell')$ -identifying code for any $\ell' < \ell$.

A digraph with adjacency matrix $A = (a_{uv})$ has eigenvalue λ and eigenvector $\mathbf{x} = (x_u)$ if and only if

$$A\mathbf{x} = \lambda\mathbf{x} \Leftrightarrow \sum_{v \in V} a_{uv}x_v = \sum_{v \in N^+(u)} x_v = \lambda x_u \quad \text{for all } u \in V. \quad (2)$$

This last equation leads to the charge displacement interpretation; for more information about it, see Fiol and Mitjana [4]. Moreover, the spectral radius of A is the largest among the absolute values of its eigenvalues.

Recall also that a *transitive tournament* TT_3 is formed by vertices u, v , and w , and arcs (u, v) , (u, w) , and (v, w) . Besides, we called *bipartite tournament* $BT_{2,2}$ to the digraph formed by vertices u, v, w and x , and arcs (u, w) , (u, x) , (v, w) and (v, x) . See both digraphs in Figure 1 (b) and Figure 1 (c), respectively.

Our first lemma is the only non-spectral result of this paper.

Lemma 2 *Let D be a d -in-regular digraph on n vertices, without any of the subdigraphs of Figure 1. If D admits a $(1, \leq \ell)$ -identifying code, then $\ell \in \{d, d + 1\}$.*

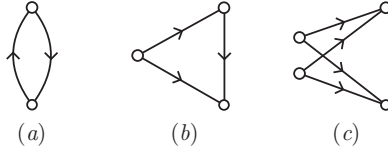

Figure 1: The subdigraphs forbidden by Lemma 2: (a) The digon, (b) TT_3 , and (c) $BT_{2,2}$.

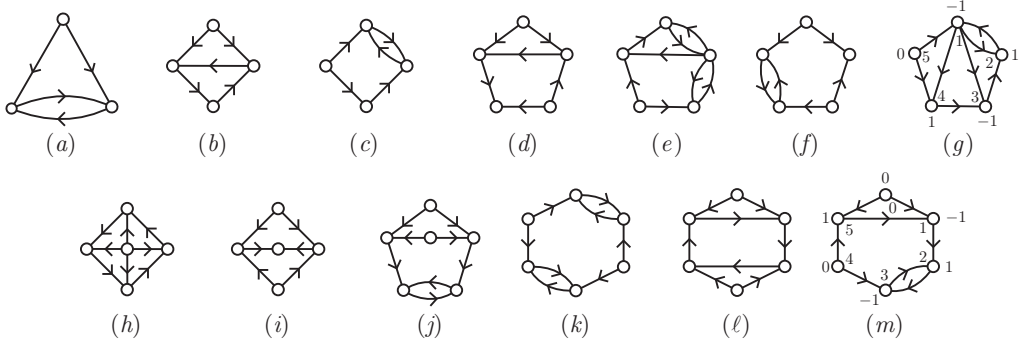

Figure 2: The forbidden subdigraphs characterizing a 2-in-regular digraph admitting a $(1, \leq 1)$ -identifying code (only (a)), or a $(1, \leq 2)$ -identifying code (all of them). The subdigraph (g) and (m) have their vertices numbered in the interior, and the entries of the eigenvector corresponding to eigenvalue -1 in the exterior.

2 Main results

We begin with a result that gives a sufficient (spectral) condition for a digraph to admit a $(1, \leq 1)$ -identifying code.

Lemma 3 *Let D be a digraph with adjacency matrix A and with a set of eigenvalues denoted by $\text{ev}(A)$. If $-1 \notin \text{ev}(A)$, then D admits a $(1, \leq 1)$ -identifying code.*

Observe that the converse is not true since, if $-1 \in \text{ev}(A)$, this does not imply that some of its corresponding eigenvectors are of the form $\mathbf{e}_i - \mathbf{e}_j$. For example, the digraph in Figure 2 (j) has -1 as an eigenvalue, but it does admit a $(1, \leq 1)$ -identifying code.

In [3] the authors gave the following theorem, which is a combinatorial characterization of a 2-in-regular digraph admitting a $(1, \leq 1)$ -, $(1, \leq 2)$ -, or $(1, \leq 3)$ -identifying code.

Theorem 4 ([3]) *Let D be a 2-in-regular digraph. Then,*

- (i) *D admits a $(1, \leq 1)$ -identifying code if and only if it does not contain any subdigraph isomorphic to Figure 2 (a).*
- (ii) *D admits a $(1, \leq 2)$ -identifying code if and only if it does not contain any subdigraph isomorphic to one of the digraphs of Figure 2.*
- (iii) *D admits a $(1, \leq 3)$ -identifying code if and only if it is oriented, TT_3 -free and does not contain any subdigraph isomorphic to one of the digraphs of Figure 3.*

Next, we present an algebraic-combinatorial sufficient condition for a 2-in-regular digraph to admit a $(1, \leq 2)$ - or $(1, \leq 3)$ -identifying code, but first we need the following lemma.

Lemma 5 *Let D' be a digraph with maximum in-degree Δ^- having an eigenvalue λ with eigenvector $\mathbf{x}' = (x'_u)$, such that $x'_v = 0$ for any vertex $v \in V(D')$ with $d^-(v) < \Delta^-$. Then, any Δ^- -in-regular digraph D containing D' as a subdigraph has also the eigenvalue λ .*

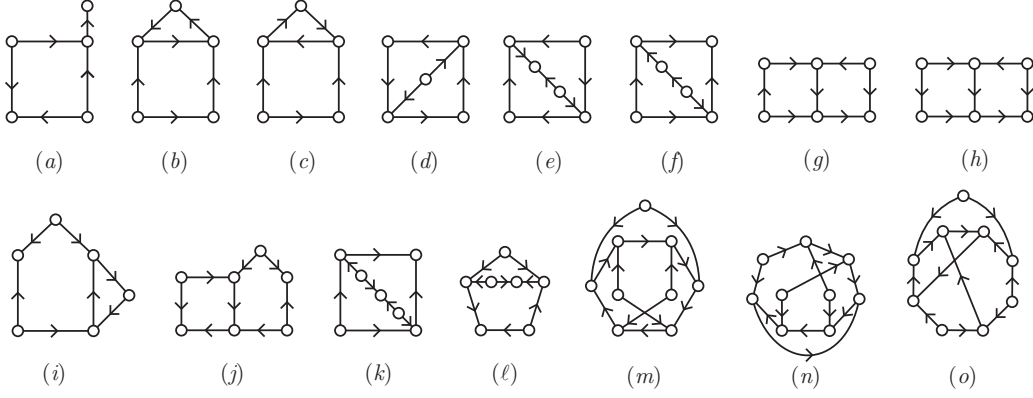

Figure 3: The forbidden subdigraphs characterizing a TT_3 -free, 2-in-regular and oriented digraph admitting a $(1, \leq 3)$ -identifying code.

Now we give an algebraic-combinatorial sufficient condition for a 2-in-regular digraph to admit a $(1, \leq 2)$ -, or $(1, \leq 3)$ -identifying code. By appealing to the eigenvalues of the digraphs we can reduce the number of forbidden subdigraphs considered in Theorem 4.

Theorem 6 *Let D be a 2-in-regular digraph with adjacency matrix A .*

- (i) *If $-1 \notin \text{ev}(A)$ and D does not contain any subdigraph isomorphic to (b), (c), (d), (f) and (i) of Figure 2, then D admits a $(1, \leq 2)$ -identifying code.*
- (ii) *If $-1, 0 \notin \text{ev}(A)$ and D does not contain any subdigraph isomorphic to (b)-(l) of Figure 3, then D admits a $(1, \leq 3)$ -identifying code.*

We provide some necessary notation introduced by Powers [8]. Let $\mathbf{x} = (x_i)$ be an eigenvector associated with an eigenvalue λ different from the spectral radius, and let \mathbf{z} be an eigenvector associated with the spectral radius. We denote by $\mathcal{P}(\mathbf{x})$ and $\mathcal{N}(\mathbf{x})$ the set of its positive and negative entries, respectively. That is, $\mathcal{P}(\mathbf{x}) = \{i : x_i > 0\}$ and $\mathcal{N}(\mathbf{x}) = \{i : x_i < 0\}$. Since \mathbf{x} and \mathbf{z} are orthogonal, $\mathcal{P}(\mathbf{x})$ and $\mathcal{N}(\mathbf{x})$ are nonempty, because all the entries of \mathbf{z} are positive.

Let us show the meaning of the sign of a real eigenvalue on the sets of in-neighborhoods of vertices.

Proposition 7 *Let $D = (V, E)$ be a digraph with adjacency matrix A having some real eigenvalue, say $\lambda \in \text{ev}(A)$, different from the spectral radius. Let $\mathbf{x} = (x_u)_{u \in V}$ be an eigenvector of A associated with λ such that $X = \mathcal{P}(\mathbf{x})$ and $Y = \mathcal{N}(\mathbf{x})$. Then, depending on the sign of λ , the following holds:*

- (a) *If $\lambda < 0$, then $X \cup N^-(X) = Y \cup N^-(Y) \iff N^-[X] = N^-[Y]$.*
- (b) *If $\lambda > 0$, then $X \cup N^-(Y) = Y \cup N^-(X)$.*
- (c) *If $\lambda = 0$, then $N^-(X) = N^-(Y)$.*

The same result holds for graphs by changing $N^-(X)$ and $N^-(Y)$ by $N(X)$ and $N(Y)$, respectively. Moreover, a similar result concerning out-neighborhoods (instead of in-neighborhoods) can be obtained by applying Proposition 7 to the converse digraph of D or, equivalently, considering the left (instead of right) eigenvectors of D . The next result gives an upper bound for ℓ in a digraph D having a $(1, \leq \ell)$ -identifying code.

Corollary 8 *Let D be a digraph admitting a $(1, \leq \ell)$ -identifying code. Let A be its adjacency matrix having at least one negative eigenvalue $-\lambda$ (with $\lambda > 0$) with $\mathbf{x} = (x_1, \dots, x_n)$ any associated eigenvector. Then $\ell < \min_{\mathbf{x}} \max\{|\mathcal{P}(\mathbf{x})|, |\mathcal{N}(\mathbf{x})|\}$.*

Example 9 Consider the digraph of Figure 2 (m). Its spectrum is $\{0^4, 1^1, -1^1\}$. An eigenvector corresponding to the eigenvalue -1 is $(0, -1, 1, -1, 0, 1)$. The positions of the positive entries of this eigenvector give us vertex subset $X = \{2, 5\}$, and the positions of the negatives give $Y = \{1, 3\}$. We can check that $N^-[X] = N^-[Y] = \{0, 1, 2, 3, 4, 5\}$. Then, this digraph does not admit a $(1, \leq 2)$ -identifying code.

To give a general result not depending on some specific eigenvector, but only on the multiplicity of the corresponding eigenvalue, we give the following lemma. More precisely, the next result shows that, given a real eigenvalue with geometric multiplicity m , some of its eigenvectors can be chosen with at least $m - 1$ zero entries.

Theorem 10 Let D be a digraph on n vertices with adjacency matrix A , and let λ be a real eigenvalue of A with geometric multiplicity m . For any given index set $I \subset \{1, 2, \dots, n\}$ with $|I| = m - 1$, there exists an eigenvector \mathbf{x} with eigenvalue λ and entries $x_i = 0$ for every $i \in I$.

Observe that Corollary 8 can also be applied to graphs, which always have real eigenvalues.

References

- [1] G. Araujo-Pardo, C. Balbuena, L. Montejano, J. C. Valenzuela. Partial linear spaces and identifying codes. **European J. Combin.** 32:344–351, 2011.
- [2] C. Balbuena, J. Salas. On the order of graphs with a given girth pair. **Discrete Math.** 321:68–75, 2014.
- [3] C. Balbuena, C. Dalfó, B. Martínez-Barona. Sufficient conditions for a digraph to admit a $(1, \leq \ell)$ -identifying code. **Discuss. Math. Graph Theory**, 2019 (accepted). <http://arxiv.org/abs/1902.04913>
- [4] M. A. Fiol, M. Mitjana. The spectra of some families of digraphs. **Linear Algebra Appl.** 423:109–118, 2007.
- [5] M. Karpovsky, K. Chakrabarty, L. Levitin. On a new class of codes for identifying vertices in graphs. **IEEE Trans. Inform. Theory** 44:599–611, 1998.
- [6] T. Laihonen. On cages admitting identifying codes. **European J. Combin.** 29:737–741, 2008.
- [7] T. Laihonen, S. Ranto. Codes identifying sets of vertices. **Notes Comput. Sci.** 2227:82–91, 2001.
- [8] D. L. Powers. Graph partitioning by eigenvectors. **Linear Algebra Appl.** 101:121–133, 1988.

Connecting edge-colouring

Jørgen Bang-Jensen, Thomas Bellitto, and Anders Yeo

Department of Mathematics and Computer Science, University of Southern Denmark,
Odense, Denmark

Research supported by the Danish research council under grant number DFF-7014-00037B.

EXTENDED ABSTRACT

1 The problem

Let $G = (V, E)$ be an undirected graph and let $c : E \mapsto [1, n]$ be a colouring of the edges of G . A walk in G is said to be properly coloured if and only if it does not use consecutively two edges of the same colour. Such walks have been introduced by Chen and Daykin in [3] and have been well-studied since (see [6] for a survey). Using this definition, edge-coloured graphs can be seen as a powerful generalization of directed graphs [2]: indeed, if D is a directed graph, we can subdivide every arc uv of G by inserting a vertex w_{uv} and we can replace the arc uv by a red edge uw_{uv} and a blue edge $w_{uv}v$. We obtain a 2-edge-coloured bipartite undirected graph with a similar set of possible walks.

More formally, in this paper, we define an edge-coloured undirected graph $G_c = (V, E, c)$ as **properly connected** if and only if for every two vertices u and v in V , there exists a properly coloured walk between u and v . In this case, we say that c is a **connecting edge-colouring** of G . For example, the edge-coloured graph depicted in Figure 1 is properly connected. The vertices v_0 and v_2 are connected by the properly coloured walk $(v_0, v_3, v_4, v_5, v_{13}, v_{12}, v_8, v_4, v_3, v_2)$. Note that the vertices of the graph only have to be connected by walks and we can thus repeat vertices or edges. The vertices of the graph of Figure 1 cannot all be connected by properly coloured elementary paths but the graph is still properly connected.

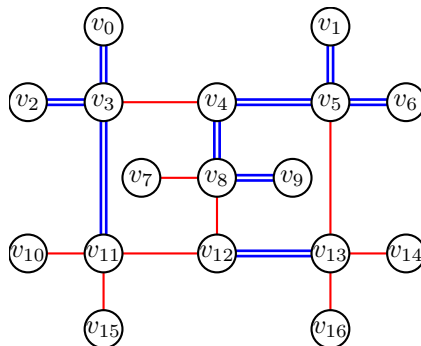

Figure 1: An example of properly connected edge-coloured graph. For readability in black and white, blue edges are represented with a double line.

We define the problem of connecting edge-colouring as follows:

Connecting edge-colouring

Input: A connected undirected graph $G = (V, E)$.

Output: The smallest number of colours k such that there exists a colouring function $c : E \mapsto [1, k]$ such that $G_c = (V, E, c)$ is properly connected.

In this abstract, the main results are given without proof. We refer the reader to [1] for more details.

2 Preliminary results

The number of colours required to connect a graph of n vertices can be anywhere between 1 and $n - 1$. Complete graphs can be properly connected with only one colour while $n - 1$ colours are required to connect a star.

The number of colours required to connect a graph is also upper bounded by the chromatic index of the graph *i.e.* the number of colours required for a proper colouring of the edges of the graph. We say that the edges of a graph are properly coloured if two adjacent edges always have different colours. In this case, every walk in the graph is properly coloured too, but this condition is far from necessary. For example, the graphs with highest chromatic indexes are the complete graphs but they are those that require the fewest colours to be connected.

The number of colours required to connect a tree is exactly its maximum degree Δ . Indeed, a greedy colouring of the edges of a rooted tree by order of increasing depth provides a proper edge-colouring of the tree using only Δ colours and thereby proves that Δ colours are enough to connect the tree. Conversely, if we colour the edges of the tree with fewer than Δ colours, every vertex u of degree Δ will have two adjacent edges, say uv and uw , with same colour and there are no properly coloured walks between v and w .

Determining if a graph can be connected with only one colour comes down to determining if the graph is complete and can be done in $O(|V| + |E|)$.

The first important result we present in this talk is the following:

Theorem 1 *Any graph with a cycle can be connected with 3 colours.*

The complexity of k -colouring for $k \geq 3$ quickly follows.

Corollary 2 *If $k \geq 3$, we can decide in polynomial time if a graph G can be connected with k colours.*

Indeed, if the graph is a tree, the question comes down to deciding if the graph has a vertex of degree strictly greater than k , which is easy. Otherwise, the answer is always yes.

Hence, the only remaining case is $k = 2$.

3 Connecting 2-edge-colouring

We start by studying bipartite graphs for which we establish the following theorem, which was proved independently by Ducoffe et al. in [4]:

Theorem 3 *A bipartite graph G can be connected with two colours if and only if it can be made 2-edge-connected by adding at most one edge.*

This criteria comes down to checking whether the tree induced by the bridges of the graph is a path, which can be done in linear time via a depth-first search.

Note that in the case of bipartite graphs, if two vertices can be connected by a properly coloured walk, then they can also be connected by a properly coloured elementary path. However, as illustrated in Figure 1, the presence of odd cycles can allow for much more complicated connecting walks.

As illustrated in Figure 2 by the graph on the left, odd cycles can make it possible to connect graphs that are arbitrarily far from being 2-edge-connected. On the other hand, the graph depicted on the right in Figure 2 can be made 2-edge-connected by adding the edge uw and still, no colouring of its edges can make it properly connected. For example, the edge-colouring depicted in the figure does not connect the vertices v and w . Thus, Theorem 3 does not extend to all graphs.

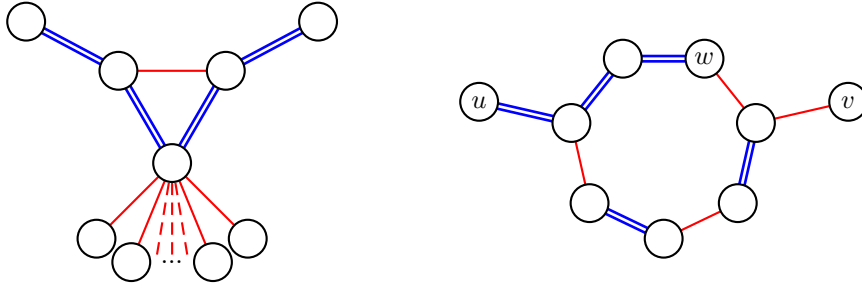

Figure 2: Counter-examples to the generalization of Theorem 3 to non-bipartite graphs.

Goddard and Melville proved the following important result on non-bipartite graphs [5]:

Theorem 4 *If a connected graph has two edge-disjoint odd cycles, then it can be connected with two colours.*

To generalize this result, we introduce the notion of stubborn edge: we define the **stubborn edges** of a graph as the edges that belong to every closed walk of odd length. We denote by \mathcal{S} the set of stubborn edges of a graph. Note that one can check whether a given edge e is stubborn in time $O(n + m)$ by checking whether $G - e$ is bipartite. In the case of a bipartite graph, every closed walk is even and every edge is therefore stubborn.

We then prove the following, which generalizes Theorem 4:

Theorem 5 *If a connected graph has no stubborn edge, then it can be connected with two colours.*

Let G be a graph and let $G \setminus \mathcal{S}$ be the graph obtained from G by removing all the stubborn edges. By an **\mathcal{S} -free component** of G , we mean a connected component of $G \setminus \mathcal{S}$. Note that all \mathcal{S} -free components are bipartite. These components are important because of the following result:

Property 6 *Let G be a non-bipartite 2-edge-coloured graph. Then, there exists an \mathcal{S} -free component \mathcal{K} of G such that there is no properly coloured walk between two vertices $u, v \notin \mathcal{K}$ that goes through a vertex of \mathcal{K} .*

Property 6 together with Theorem 3 provides a strong necessary condition for a non-bipartite graph to have a connecting 2-edge-colouring. We can prove that this condition is also sufficient and we obtain the following characterization of the graphs that can be connected with two colours:

Theorem 7 *A connected non-bipartite graph G can be connected with two colours if and only if there exists an \mathcal{S} -free component \mathcal{K} of G such that $G \setminus \mathcal{K}$ is empty or can be made 2-edge-connected by adding at most one edge.*

The proof of all our theorems are constructive and we can derive polynomial algorithms for optimal connecting edge-colouring from them. Putting all together, we obtain the following theorem:

Theorem 8 *The minimum number of colours required by a connecting edge-colouring of a graph G is:*

- 1 if G is complete;

- its maximum degree $\Delta(G)$ if G is a tree;
- 2 if G is bipartite and can be made 2-edge-connected by adding at most one edge;
- 2 if G is non-bipartite and contains an S -free component \mathcal{K} such that $G \setminus \mathcal{K}$ is empty or can be made 2-edge-connected by adding at most one edge;
- 3 otherwise

Furthermore, in every case, an optimal connecting colouring can be found in polynomial time.

References

- [1] J. Bang-Jensen, T. Bellitto, A. Yeo. Connecting edge-colouring. In **Arxiv**, abs/1907.00428, 2019.
- [2] J. Bang-Jensen, G. Gutin. Digraphs - theory, algorithms and applications. Springer, 2009.
- [3] C. Chen, D. Daykin. Graphs with Hamiltonian cycles having adjacent lines different colors. In **J. Comb. Theory, Ser. B** 21:135–139, 1976.
- [4] G. Ducoffe, R. Marinescu-Ghemeci, A. Popa. On the (di)graphs with (directed) proper connection number two. To appear in **Discrete Applied Mathematics**, 2019.
- [5] W. Goddard, R. Melville. Coloring Graphs to Produce Properly Colored Walks. In **Graphs and Combinatorics**, 33:1271–1281, 2017.
- [6] G. Gutin, E. J. Kim. Properly Coloured Cycles and Paths: Results and Open Problems. In **Graph Theory, Computational Intelligence and Thought, Essays Dedicated to Martin Charles Golumbic on the Occasion of His 60th Birthday**, 200–208, 2009.

Linear transformations between colorings in chordal graphs

Nicolas Bousquet and Valentin Bartier

Univ. Grenoble Alpes, CNRS, Grenoble INP, G-SCOP, France

EXTENDED ABSTRACT

1 Introduction

Reconfiguration problems consist in finding step-by-step transformations between two feasible solutions of a problem such that all intermediate states are also feasible. Such problems model dynamic situations where a given solution already in place has to be modified for a more desirable one while maintaining some properties throughout the transformation. Two main questions are at the core of combinatorial reconfiguration. (i) Is it possible to transform any solution into any other? (ii) If yes, how many steps are needed to perform this transformation? These two questions and their algorithmic counterparts received considerable attention.

Graph recoloring. Throughout the paper, $G = (V, E)$ denotes a graph, $n = |V|$, Δ denotes the maximum degree of G , and k is an integer.

A (proper) k -coloring of G is a function $f : V(G) \rightarrow \{1, \dots, k\}$ such that, for every edge $xy \in E$, we have $f(x) \neq f(y)$. Since we will only consider proper colorings, we will then omit the proper for brevity. The *chromatic number* $\chi(G)$ of a graph G is the smallest k such that G admits a k -coloring. Two k -colorings are *adjacent* if they differ on exactly one vertex. The *k -reconfiguration graph* of G , denoted by $\mathcal{G}(G, k)$ and defined for any $k \geq \chi(G)$, is the graph whose vertices are k -colorings of G , with the adjacency condition defined above. The *k -recoloring diameter* of a graph G is the diameter of $\mathcal{G}(G, k)$ if $\mathcal{G}(G, k)$ is connected and is $+\infty$ otherwise. In other words, it is the minimum D for which any k -coloring can be transformed into any other one through a sequence of at most D single vertex recolorings.

A graph G is *d -degenerate* if any subgraph of G admits a vertex of degree at most d . In other words, there exists an ordering v_1, \dots, v_n of the vertices such that for every i , v_i has at most d neighbors in v_{i+1}, \dots, v_n . It was shown independently by Dyer et al. [7] and by Cereceda et al. [6] that for any d -degenerate graph G and every $k \geq d + 2$, $\mathcal{G}(G, k)$ is connected. Note that the bound on k is the best possible since the $\mathcal{G}(K_n, n)$ is not connected (and K_n is $(n - 1)$ -degenerate). Cereceda [5] conjectured the following:

Conjecture 1 (Cereceda [5]) *For every d , every $k \geq d + 2$, and every d -degenerate graph G , the diameter of $\mathcal{G}(G, k)$ is at most $C_d \cdot n^2$.*

If true, the quadratic function is the best possible, even for paths, as shown in [2]. Bousquet and Heinrich [3] recently proved that the diameter of $\mathcal{G}(G, k)$ is $O(n^{d+1})$. Cereceda's conjecture is only known to be true for $d = 1$ (trees) [2] and $d = 2$ and $\Delta \leq 3$ [8]. The diameter of $\mathcal{G}(G, k)$ is $O(n^2)$ when $k \geq \frac{3}{2}(d+1)$ in [3]. Even if Cereceda's conjecture is widely open for general graphs, it has been proved for a few graph classes, e.g. chordal graphs [2], bounded treewidth graphs [1], and bipartite planar graphs [3].

The diameter of $\mathcal{G}(G, k)$ is linear if $k \geq 2d + 2$ [4] or if k is at least the Grundy number of G plus 1 [1]. When $k = d + 2$, the diameter of $\mathcal{G}(G, k)$ may be quadratic, even for paths [2]. But it might be true that the diameter of $\mathcal{G}(G, k)$ is linear whenever $k \geq d + 3$. In this paper, we investigate the following question, raised for instance in [3]: when does the k -recoloring diameter of d -degenerate graphs becomes linear?

Our results. A graph is *chordal* if it does not contain any induced cycle of length at least 4. Chordal graphs admit a simplicial elimination ordering, i.e. there exists an ordering v_1, \dots, v_n of V such that, for every i , $N[v_i] \cap \{v_{i+1}, \dots, v_n\}$ is a clique. Chordal graphs are

$(\omega(G) - 1)$ -degenerate where $\omega(G)$ is the size of a maximum clique of G . Our main result is the following:

Theorem 2 *Let Δ be a fixed integer. Let G be a d -degenerate chordal graph of maximum degree Δ . For every $k \geq d + 4$, the diameter of $\mathcal{G}(G, k)$ is at most $O(n)$. Moreover, given two colorings c_1, c_2 of G , a transformation of length at most $O(n)$ can be found in linear time.*

Note that the bound on k is almost the best possible since we know that this result cannot hold for $k \leq d + 2$ [2]. So there is only one remaining case which is the case $k = d + 3$. Let us roughly describe the idea of our method on interval graphs. A buffer \mathcal{B} is a set of vertices contained in $f(\omega)$ consecutive cliques of the clique path. We assume that at the left of the buffer, the coloring of the graph already matches the target coloring. We moreover assume that the coloring of \mathcal{B} is special in the sense that, for every vertex v in \mathcal{B} , at most $d + 2$ colors appear in the neighborhood of v ¹. Note that in order to satisfy this property, the buffer has to be “long enough”. The main technical part of the proof consists in showing that if the buffer is “long enough”, then we can only modify the colors of the vertices of the buffer in such a way the same assumptions hold for the buffer starting one clique to the right of the starting clique of \mathcal{B} . We simply have to repeat at most n times this operation to guarantee that the coloring of the whole graph is the target coloring. Since a vertex is recolored only if it is in the buffer and a vertex is in the buffer a constant (assuming Δ constant) number of times, every vertex is recolored a constant number of times.

2 Buffer, blocks and regions

Throughout this section, $G = (V, E)$ is a chordal graph on n vertices of maximum clique number ω , maximum degree Δ and T is a clique tree of G rooted in an arbitrary node. Let $k \geq \omega + 3$ be the number of colors denoted by $1, \dots, k$. Given two integers $x \leq y$, $\llbracket x, y \rrbracket$ is the set $\{x, x + 1, \dots, y\}$. The *closed neighbourhood* of a set $S \subseteq V$ is $N[S] := S \cup (\cup_{v \in S} N(v))$.

Vertex ordering and canonical coloring. Let v_1, v_2, \dots, v_n be a perfect elimination ordering of $V(G)$. A greedy coloring of v_n, v_{n-1}, \dots, v_1 gives an optimal coloring c_0 of G using only ω colors. The coloring c_0 is called the *canonical coloring* of G . The colors $c \in 1, 2, \dots, \omega$ are the *canonical colors* and the colors $c > \omega$ are *non-canonical*. Note that the independent sets $X_i := \{v \in V \text{ such that } c_0(v) = i\}$ for $i \leq \omega$, called the *classes* of G , partition the vertex set V .

Let C_e be a clique of T . We denote by T_{C_e} the subtree of T rooted in C_e and by $h_{C_e}(C)$ the height of the clique $C \in T_{C_e}$. Given a vertex $v \in T_{C_e}$, we say that v *starts* at height h if the maximum height of a clique of T_{C_e} containing v is h (in T_{C_e}).

Let $s := 3\binom{\omega}{2} + 2$ and $N = s + k - \omega + 1$ (where k is the number of colors). The *buffer* \mathcal{B} rooted in C_e is the set of vertices of G that start at height at most $3\Delta N - 1$ in T_{C_e} . For every $0 \leq i \leq 3N - 1$, the *block* Q_{3N-i} of \mathcal{B} is the set of vertices of G that start at height h with $i\Delta \leq h \leq (i + 1)\Delta - 1$. Finally, for $0 \leq i \leq N - 1$, the *region* R_i of \mathcal{B} is the set of blocks $Q_{3i+1}, Q_{3i+2}, Q_{3(i+1)}$. Unless stated otherwise, we will always denote the three blocks of R_i by A_i, B_i and C_i , and the regions of a buffer \mathcal{B} by R_1, \dots, R_N . Given a color class X_p and a $S \subseteq V$, we denote by $N[S, k]$ the set $N[S \cap X_k]$. By definition of a block we have:

Property 3 *Let C_e be a clique of T and \mathcal{B} be the buffer rooted in T_{C_e} . Let Q_{i-1}, Q_i, Q_{i+1} be three consecutive blocks of \mathcal{B} . Then $N[Q_i] \subseteq Q_{i-1} \cup Q_i \cup Q_{i+1}$. In particular for each region $R_i = (A_i, B_i, C_i)$ of \mathcal{B} , $N[B_i] \subseteq R_i$.*

¹Our condition is actually even more restrictive.

2.1 Vectorial coloring and valid buffer

Let \mathcal{B} be a buffer. We denote the set of vertices of class p that belong to the sequence of blocks Q_i, \dots, Q_j of \mathcal{B} by (Q_i, \dots, Q_j, p) . A *color vector* ν is a vector of size ω such that $\nu(p) \in \llbracket 1, k \rrbracket$ for every $p \in \llbracket 1, \omega \rrbracket$, and $\nu(p) \neq \nu(q)$ for every $p \neq q$. A block Q is *well-colored for a color vector* ν_Q (or just *well-colored* if ν is clear from context) if all the vertices of (Q, p) are colored with $\nu_Q(p)$. For brevity, we say that (Q, ν_Q) is *well-colored*. Note that a well-colored block is properly colored. Since the set (Q, p) may be empty, a block may be well-colored for different vectors. However, a color vector defines a unique coloring of the vertices of block. The color vector ν is *canonical* if $\nu(p) = p$ for every $p \leq \omega$. A sequence of blocks Q_1, \dots, Q_r is *well-colored for* (ν_1, \dots, ν_r) if (Q_i, ν_i) is well-colored for every $i \leq r$.

Let $\mathcal{B} = R_1, R_2, \dots, R_N$ be a buffer such that all the regions $R_i = A_i, B_i, C_i$ are well-colored for the vectors $\nu_{A_i}, \nu_{B_i}, \nu_{C_i}$. So \mathcal{B} is well-colored for $\nu = (\nu_{A_1}, \nu_{B_1}, \nu_{C_1}, \nu_{A_2}, \dots, \nu_{C_N})$. The buffer (\mathcal{B}, ν) is *valid* if for every $i \in \llbracket 1, N \rrbracket$, the number of different colors in ν_{A_i}, ν_{B_i} and ν_{C_i} is at most $\omega + 2$, $\nu_{A_{i+1}} = \nu_{C_i}$ for all i in $\llbracket 1, N - 1 \rrbracket$, and an additional number of technical properties are verified².

Note that if (\mathcal{B}, ν) is valid, then every vertex of \mathcal{B} has at most $\omega + 2$ colors in its neighbourhood in $G[\mathcal{B}]$ due to Property 3. Then, as $k \geq \omega + 3$, there always exists a color that does not appear locally and that we can use to modify the coloring of the buffer.

3 Algorithm outline

Let G be a chordal graph of maximum degree Δ and maximum clique size ω , T be a clique tree of G , and ϕ be any k -coloring of G . We propose an iterative algorithm that recolors the vertices of T from the leaves to the root until we obtain the canonical coloring c_0 defined previously. Let S be a clique of T . A coloring α of G is *treated up to* S if:

1. Vertices starting at height more than $3\Delta N$ in T_S are colored canonically, and
2. The buffer rooted at S is valid.

Let C be a clique of T . We associate a vector ν_C of length ω to the clique C as follows. We set $\nu_C(\ell) = \alpha(v)$ if there exists $v \in X_\ell \cap C$. Then we arbitrarily complete ν_C in such a way all the coordinates of ν_C are distinct (which is possible since $|\nu_C| < k$).

Theorem 2 is a consequence of the following lemmas.

Lemma 4 *Let C be a clique associated with ν_C . Let S be a child of C in T , \mathcal{B} be the buffer rooted at S and ν be a vector sequence such that (\mathcal{B}, ν) is valid. There exists a recoloring sequence of $\cup_{i=2}^N R_i$ such that the resulting coloring ν' satisfies $\nu'_{C_N} = \nu_C$ and (\mathcal{B}, ν') is valid. Moreover, every vertex of $\cup_{i=s}^N R_i$ is recolored at most $O(\omega)$ times.*

In other words, Lemma 4 allows us to obtain a coloring of G such that the coloring of the first cliques of T_S match the coloring of C while maintaining a valid buffer.

Let C be a clique and S_1, S_2 be two children of C . For every $i \leq 2$, let \mathcal{B}_i be the buffer of S_i and assume that \mathcal{B}_i is valid for ν^i . We say that \mathcal{B}_1 and \mathcal{B}_2 have *the same coloring* if $\nu^1 = \nu^2$.

Lemma 5 *Let C be a clique associated with ν_C . Let S_1, S_2, \dots, S_e be the children of C , and for every $i \leq e$, \mathcal{B}_i be the buffer rooted at S_i . Let ν^i be a vectorial coloring such that (\mathcal{B}_i, ν^i) is valid. If $D_{\mathcal{B}_i}(\nu_C, \nu^i) = 0$ for every $i \leq e$, then there exists a recoloring sequence of $\cup_{j=2}^{N-1} R_j^i$ such that every coordinate is recolored $O(\omega^2)$ times, the final coloring of all the \mathcal{B}_i s is the same coloring ν' , $D_{\mathcal{B}_i}(\nu_C, \nu') = 0$, and (\mathcal{B}_i, ν') is valid for every $i \leq e$.*

Given the children S_1, S_2, \dots, S_e of C , Lemma 5 ensures that we can obtain the same coloring for all the buffers while maintaining proper colorings all along. Finally, Lemma 6 shows how we can use such colorings to "shift" the valid buffer one clique up in the tree:

²Due to size restriction we can not give them in this extended abstract.

Lemma 6 *Let C be a clique of T with children S_1, S_2, \dots, S_e and let α be a k -coloring of G treated up to S_i for every $i \in \llbracket 1, e \rrbracket$. Let ν_C be a vector associated with C and $\mathcal{B}_i = R_1^i, \dots, R_N^i$ denote the buffer rooted at S_i . Assume that there exists ν such that (\mathcal{B}_i, ν) is valid for every $i \leq e$ and satisfies $\nu_N = \nu_C$. Then there exists a recoloring sequence of $\cup_{i \leq e} \cup_{j=2}^{N-1} R_j^i$ such that, every vertex is recolored at most one time and such that the resulting coloring of G is treated up to C .*

Let us now briefly describe how we can use Lemmas 4 to 6 to derive Theorem 2. Let c_0 be the canonical coloring of G and T be a clique tree of G . Let us first show that given a clique $C \in T$ with children S_1, \dots, S_e and a coloring α treated up to S_i for every $i \leq e$, we can obtain a coloring of G treated up to C . Let ν_C be a vector associated with C . For every $i \leq e$, let \mathcal{B}_i be the buffer rooted in S_i and ν_i be a vectorial coloring of \mathcal{B}_i such that (\mathcal{B}_i, ν^i) is valid. For every $i \leq e$, by applying Lemmas 4 to (\mathcal{B}_i, ν^i) , we obtain a vectorial coloring ν^i such that (\mathcal{B}_i, ν^i) is valid and $\nu_{C_N}^i = \nu_C$. By Lemma 5, we can recolor each ν^i into ν' such that for every i , (\mathcal{B}_i, ν') is valid and $\nu'_{C_N} = \nu_C$. Then we can apply Lemma 6 to obtain a coloring of G such that the buffer (\mathcal{B}, ν) rooted in C is valid. Since no vertex starting in cliques $W \in T_C$ with $h_C(W) > 3\Delta N$ is recolored, these vertices remain canonically colored and the resulting coloring of G is treated up to C . Note that only vertices of T_C that start in cliques of height at most $3\Delta N$ are recolored at most $O(\omega^2)$ times to obtain a coloring treated up to C .

By applying this process from the leaves to the root of T , we can recolor any k -coloring of G into c_0 in a linear number of steps, and thus we can recolor any k -coloring into any other in a linear number of steps. Furthermore, a clique tree of G can be computed in linear time [9] and parents can be determined in constant time (assuming a linear time pre-processing via a breadth-first search), and thus the algorithm runs in linear time.

References

- [1] M. Bonamy and N. Bousquet. Recoloring graphs via tree decompositions. *Eur. J. Comb.*, 69:200–213, 2018.
- [2] M. Bonamy, M. Johnson, I. Lignos, V. Patel, and D. Paulusma. Reconfiguration graphs for vertex colourings of chordal and chordal bipartite graphs. *Journal of Combinatorial Optimization*, pages 1–12, 2012.
- [3] N. Bousquet and M. Heinrich. A polynomial version of Cereceda’s conjecture. *arXiv e-prints*, 2019.
- [4] N. Bousquet and G. Perarnau. Fast recoloring of sparse graphs. *Eur. J. Comb.*, 52:1–11, 2016.
- [5] L. Cereceda. *Mixing Graph Colourings*. PhD thesis, London School of Economics and Political Science, 2007.
- [6] L. Cereceda, J. van den Heuvel, and M. Johnson. Mixing 3-colourings in bipartite graphs. *Eur. J. Comb.*, 30(7):1593–1606, 2009.
- [7] M. Dyer, A. D. Flaxman, A. M. Frieze, and E. Vigoda. Randomly coloring sparse random graphs with fewer colors than the maximum degree. *Random Structures & Algorithms*, 29(4):450–465, 2006.
- [8] C. Feghali, M. Johnson, and D. Paulusma. A reconfigurations analogue of brooks’ theorem and its consequences. *Journal of Graph Theory*, 83(4):340–358, 2016.
- [9] P. Galinier, M. Habib, and C. Paul. Chordal graphs and their clique graphs. In M. Nagl, editor, *Graph-Theoretic Concepts in Computer Science*, pages 358–371, Berlin, Heidelberg, 1995. Springer Berlin Heidelberg.

Domination versus edge domination

*Julien Baste*¹, *Maximilian Fürst*¹, *Michael A. Henning*²,
*Elena Mohr*¹, and *Dieter Rautenbach*¹

¹ Institute of Optimization and Operations Research, Ulm University, Germany

² Department of Mathematics and Applied Mathematics, University of Johannesburg,
South Africa

EXTENDED ABSTRACT

We consider finite, simple, and undirected graphs, and use standard terminology. Let G be a graph. A set D of vertices of G is a *dominating set* in G if every vertex in $V(G) \setminus D$ has a neighbor in D , and the *domination number* $\gamma(G)$ of G is the minimum cardinality of a dominating set in G . For a set M of edges of G , let $V(M)$ denote the set of vertices of G that are incident with an edge in M . The set M is a *matching* in G if the edges in M are pairwise disjoint, that is, $|V(M)| = 2|M|$. A matching M in G is *maximal* if it is maximal with respect to inclusion, that is, the set $V(G) \setminus V(M)$ is independent. Let the *edge domination number* $\gamma_e(G)$ of G be the minimum size of a maximal matching in G . A maximal matching in G of size $\gamma_e(G)$ is a *minimum maximal matching*.

A natural connection between the domination number and the edge domination number of a graph G becomes apparent when considering the line graph $L(G)$ of G . Since a maximal matching M in G is a maximal independent set in $L(G)$, the edge domination number $\gamma_e(G)$ of G equals the independent domination number $i(L(G))$ of $L(G)$. Since $L(G)$ is always claw-free, and since the independent domination number equals the domination number in claw-free graphs [1], $\gamma_e(G)$ actually equals the domination number $\gamma(L(G))$ of $L(G)$. While the domination number [6] and the edge domination number [9], especially with respect to computational hardness and algorithmic approximability [2, 3, 4, 5, 7, 8], have been studied extensively for a long time, little seems to be known about their relation. For regular graphs, we conjecture the following:

Conjecture 1 *If G is a Δ -regular graph with $\Delta \geq 1$, then $\gamma(G) \leq \gamma_e(G)$.*

The conjecture is trivial for $\Delta \leq 2$, and fails for non-regular graphs, see Figure 1. Note that for every graph G without isolated vertices and a maximal matching M in G , the set of vertices that are incident with an edge in M is a dominating set. Hence, we obtain $\gamma(G) \leq 2\gamma_e(G)$ for every graph G without isolated vertices.

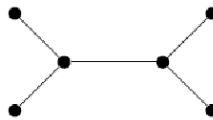

Figure 1: A non-regular graph G with $\gamma(G) = 2 > 1 = \gamma_e(G)$.

Our contributions are three results related to Conjecture 1. A simple probabilistic argument implies a weak version of Conjecture 1, which approaches the desired bound for large Δ .

Theorem 2 *If G is a Δ -regular graph with $\Delta \geq 1$, then $\gamma(G) \leq \left(1 + \frac{2(\Delta-1)}{\Delta^{2\Delta}}\right) \gamma_e(G)$.*

Proof: Let M be a minimum maximal matching in G . Since every vertex in $V(G) \setminus V(M)$ has Δ neighbors in $V(M)$, and every vertex in $V(M)$ has at most $\Delta - 1$ neighbors in $V(G) \setminus V(M)$, we have

$$\Delta(n - 2\gamma_e(G)) \leq 2(\Delta - 1)\gamma_e(G), \tag{1}$$

where n is the order of G .

Let the set D arise by selecting, for every edge in M , one of the two incident vertices independently at random with probability $1/2$. Clearly, $|D| = \gamma_e(G)$. If u is a vertex in $V(G) \setminus V(M)$, then u has no neighbor in D with probability at most $1/2^\Delta$. Note that u might be adjacent to both endpoints of some edge in M in which case it always has a neighbor in D . If B is the set of vertices in $V(G) \setminus V(M)$ with no neighbor in D , then linearity of expectation implies

$$\mathbb{E}[|B|] = \sum_{u \in V(G) \setminus V(M)} \mathbb{P}[u \in B] \leq \frac{|V(G) \setminus V(M)|}{2^\Delta} = \frac{n - 2\gamma_e(G)}{2^\Delta}.$$

Since $D \cup B$ is a dominating set in G , the first moment method implies

$$\gamma(G) \leq |D| + \mathbb{E}[|B|] = \gamma_e(G) + \frac{n - 2\gamma_e(G)}{2^\Delta} \stackrel{(1)}{\leq} \gamma_e(G) + \frac{2(\Delta - 1)\gamma_e(G)}{\Delta 2^\Delta},$$

which completes the proof. \square

For cubic graphs, Theorem 2 implies $\gamma(G) \leq \frac{7}{6}\gamma_e(G)$, which we improve with our next result. Even though the improvement is rather small, we believe that it is interesting especially because of the approach used in its proof.

Theorem 3 *If G is a cubic graph, then $\gamma(G) \leq (\frac{7}{6} - \frac{1}{204})\gamma_e(G)$.*

Finally, we show Conjecture 1 for cubic claw-free graphs.

Theorem 4 *If G is a cubic claw-free graph, then $\gamma(G) \leq \gamma_e(G)$.*

Proof: Let M be a minimum maximal matching in G . Let the set D of $|M|$ vertices intersecting each edge in M be chosen such that the set $B = \{u \in V(G) \setminus V(M) : |N_G(u) \cap D| = 0\}$ is smallest possible. For a contradiction, we may suppose that B is non-empty. Let $C = \{u \in V(G) \setminus V(M) : |N_G(u) \cap D| = 1\}$. Let b be a vertex in B . Let $u_{-1}v_{-1}$, u_0v_0 , and u_1v_1 in M be such that $N_G(u) = \{v_{-1}, v_0, v_1\}$. Since D intersects each edge in M , we have $u_{-1}, u_0, u_1 \in D$. Since G is claw-free, we may assume, by symmetry, that v_0 and v_1 are adjacent, which implies that v_{-1} is not adjacent to v_0 or v_1 . Let x be the neighbor of v_{-1} distinct from u_{-1} and b . Since G is claw-free, the vertex x is adjacent to u_{-1} . If $x = u_0$, then u_0 has no neighbor in C , and exchanging u_0 and v_0 within D reduces $|B|$, which is a contradiction. Hence, by symmetry between u_0 and u_1 , the vertex x is distinct from u_0 and u_1 . Since exchanging u_1 and v_1 within D does not reduce $|B|$, the vertex u_1 has a neighbor c_1 in C , which is necessarily distinct from x .

Now, let $\sigma : v_1, u_1, c_1, v_2, u_2, c_2, \dots, v_k, u_k, c_k$ be a maximal sequence of distinct vertices from $V(G) \setminus \{u_{-1}, u_0, v_{-1}, v_0, b, x\}$ such that $u_i v_i \in M$, $u_i \in D$, $c_i \in C$, u_i is adjacent to c_i for every $i \in [k]$, and v_{i+1} is adjacent to u_i for every $i \in [k-1]$. Let $X = \{u_{-1}, u_0, v_{-1}, v_0, b, x\} \cup \{v_1, u_1, c_1, v_2, u_2, c_2, \dots, v_k, u_k, c_k\}$, and see Figure 2 for an illustration.

Let v_{k+1} be the neighbor of u_k distinct from v_k and c_k . Since G is claw-free, the vertex v_{k+1} is adjacent to c_k . Since $V(G) \setminus V(M)$ is independent, we have $u_{k+1}v_{k+1} \in M$ for some vertex u_{k+1} . Since $c_k \in C$ and $u_k \in D$, we obtain $v_{k+1} \notin D$ and $u_{k+1} \in D$, which implies that the vertex v_{k+1} does not belong to X .

If u_{k+1} belongs to X , then $u_{k+1} = x$, and replacing D with

$$D' = (D \setminus \{u_1, u_2, \dots, u_{k+1}\}) \cup \{v_1, v_2, \dots, v_{k+1}\}$$

reduces $|B|$, which is a contradiction. Hence, the vertex u_{k+1} does not belong to X . If u_{k+1} has a neighbor c_{k+1} in C , then, by the structural conditions, the vertex c_{k+1} does not belong to X , and the sequence σ can be extended by appending $v_{k+1}, u_{k+1}, c_{k+1}$, contradicting its choice. Hence, the vertex u_{k+1} has no neighbor in C , and replacing D with the set D' as above again reduces $|B|$. This final contradiction completes the proof. \square

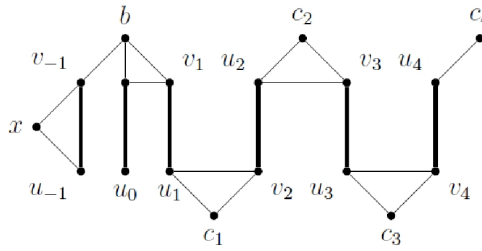

Figure 2: A subgraph of G with vertex set X , where $k = 4$.

References

- [1] R.B. Allan and R. Laskar, On domination and independent domination numbers of a graph, *Discrete Mathematics* 23 (1978) 73-76.
- [2] Z. Caner Taşkin and T. Ekim, Integer programming formulations for the minimum weighted maximal matching problem, *Optimization Letters* 6 (2012) 1161-1171.
- [3] R. Carr, T. Fujito, G. Konjevod, and O. Parekh, A $2\frac{1}{10}$ -approximation algorithm for a generalization of the weighted edge-dominating set problem, *Journal of Combinatorial Optimization* 5 (2001) 317-326.
- [4] M. Chlebík and J. Chlebíková, Approximation hardness of edge dominating set problems, *Journal of Combinatorial Optimization* 11 (2006) 279-290.
- [5] Z. Gotthilf, M. Lewenstein, and E. Rainshmidt, A $\left(2 - c\frac{\log n}{n}\right)$ approximation algorithm for the minimum maximal matching problem, *Lecture Notes in Computer Science* 5426 (2009) 267-278.
- [6] T.W. Haynes, S.T. Hedetniemi, and P.J. Slater, *Fundamentals of Domination in Graphs*, Marcel Dekker, Inc., New York, 1998.
- [7] J.D. Horton and K. Kilakos, Minimum edge dominating sets, *SIAM Journal on Discrete Mathematics* 6 (1993) 375-387.
- [8] R. Schmieđ and C. Viehmann, Approximating edge dominating set in dense graphs, *Theoretical Computer Science* 414 (2012) 92-99.
- [9] M. Yannakakis and F. Gavril, Edge dominating sets in graphs, *SIAM Journal on Applied Mathematics* 38 (1980) 364-372.

Bounding and approximating minimum maximal matchings in regular graphs

*Julien Baste*¹, *Maximilian Fürst*¹, *Michael A. Henning*²,
*Elena Mohr*¹, and *Dieter Rautenbach*¹

¹ Institute of Optimization and Operations Research, Ulm University, Germany

² Department of Mathematics and Applied Mathematics, University of Johannesburg, South Africa

EXTENDED ABSTRACT

We consider finite, simple, and undirected graphs, and use standard terminology. Let G be a graph and let M be a set of edges of G . Let $V(M)$ denote the set of vertices of G that are incident with an edge in M . The set M is a *matching* in G if the edges in M are pairwise disjoint. A matching M in G is *maximal* if it is maximal with respect to inclusion, that is, the set $V(G) \setminus V(M)$ is independent. Let the *edge domination number* $\gamma_e(G)$ of G be the minimum size of a maximal matching in G . A maximal matching in G of size $\gamma_e(G)$ is a *minimum maximal matching*.

The edge domination number and minimum maximal matchings have been studied for a long time. Yannakakis and Gavril [12] showed that finding a minimum maximal matching is NP-hard even for planar graphs or bipartite graphs of maximum degree 3. Stronger hardness and inapproximability results were obtained [7, 6, 10], and heuristics as well as approximation algorithms were studied [1, 2, 3, 5, 8, 9].

In the present paper we consider upper bounds on the edge domination number and their algorithmic consequences. We state the following conjecture as a starting point.

Conjecture 1 *If G is a connected Δ -regular graph of order n for some $\Delta \geq 3$, then*

$$\gamma_e(G) \leq \frac{2\Delta - 1}{4\Delta}n + \frac{1}{2} \quad (1)$$

with equality in (1) if and only if G has a spanning subgraph that is the union of an odd number of copies of $K_{\Delta, \Delta} - e$, see Figure 1.

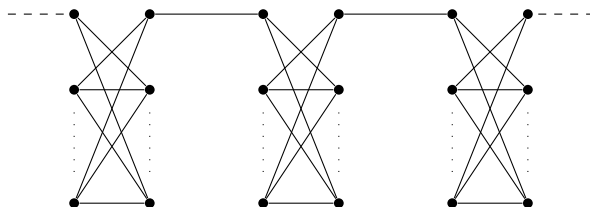

Figure 1: The extremal graphs of Conjecture 1.

Our two main results imply weak versions of Conjecture 1. Firstly, we prove Conjecture 1 for $\Delta = 3$ under more restrictive assumptions. Let T^* be the tree that arises by subdividing exactly two edges of a claw $K_{1,3}$ exactly once. Recall that a graph is T^* -free if it does not contain T^* as an induced subgraph.

Theorem 2 *If G is a connected cubic graph of order n that is bipartite and T^* -free, then*

$$\gamma_e(G) \leq \frac{5}{12}n + \frac{1}{2}.$$

In view of the extremal graphs from Conjecture 1, the bound in Theorem 2 is still best possible. Secondly, we prove a weaker bound for general Δ .

Theorem 3 *If G is a connected Δ -regular graph of order n for some $\Delta \geq 3$, then*

$$\gamma_e(G) \leq \frac{\Delta(2\Delta - 3)n + 2\Delta}{2(\Delta - 1)(2\Delta - 1)} \quad (2)$$

with equality if and only if G is $K_{\Delta, \Delta}$.

The proofs of Theorems 2 and 3 rely on bounds for non-regular graphs given in the next section that are of interest on their own right.

Since our proofs yield efficient algorithms to construct maximal matchings whose sizes are at most the corresponding upper bounds, some simple lower bounds on the edge domination number based on double counting yield approximation algorithms that improve some known results [1, 2, 3, 5, 8, 9] for restricted classes of graphs.

Theorem 4 *Let Δ be an integer at least 3.*

For every fixed $\epsilon > 0$, there are polynomial time approximation algorithms for the minimum maximal matching problem that have approximation ratios

- $\frac{25}{18} + \epsilon$ *for connected cubic bipartite T^* -free graphs,*
- $2 - \frac{1}{\Delta-1} + \epsilon$ *for connected Δ -regular graphs, and*
- $1 + \frac{4\Delta-7}{2\Delta^2-3\Delta+1} + \epsilon$ *for connected claw-free Δ -regular graphs.*

The proofs of Theorem 2 and Theorem 3 are based on the following two results.

Proposition 5 *If G is a subcubic bipartite T^* -free graph of order n and size m such that no component of G is cubic, then*

$$\gamma_e(G) \leq \frac{2n}{3} - \frac{m}{6}. \quad (3)$$

Furthermore, a maximal matching whose size is at most the right hand side of (3) can be found efficiently.

Proposition 6 *If G is a graph of order n , size m , and maximum degree at most Δ for some integer $\Delta \geq 3$ such that no component of G is Δ -regular, then*

$$\gamma_e(G) \leq \frac{\Delta n}{2\Delta - 1} - \frac{m}{(\Delta - 1)(2\Delta - 1)}, \quad (4)$$

with equality if and only if

- Δ *is odd and every component of G is $K_{\Delta-1, \Delta-1}$, or*
- Δ *is even and every component of G is $K_{\Delta-1, \Delta-1}$ or K_{Δ} .*

Furthermore, a maximal matching whose size is at most the right hand side of (4) can be found efficiently.

References

- [1] Z. Caner Taşkin and T. Ekmim, Integer programming formulations for the minimum weighted maximal matching problem, *Optimization Letters* 6 (2012) 1161-1171.
- [2] J. Cardinal, M. Labbé, S. Langerman, E. Levy, and H. Mélot, A tight analysis of the maximal matching heuristic, *Lecture Notes in Computer Science*, 3595 (2005) 701-709.

- [3] J. Cardinal, S. Langerman, and E. Levy, Improved approximation bounds for edge dominating set in dense graphs, *Theoretical Computer Science* 410 (2009) 949-957.
- [4] D.M. Cardoso, J.O. Cerdeira, C. Delorme, and P.C. Silva, Efficient edge domination in regular graphs, *Discrete Applied Mathematics* 156 (2008) 3060-3065.
- [5] R. Carr, T. Fujito, G. Konjevod, and O. Parekh, A $2\frac{1}{10}$ -approximation algorithm for a generalization of the weighted edge-dominating set problem, *Journal of Combinatorial Optimization* 5 (2001) 317-326.
- [6] M. Chlebík and J. Chlebíková, Approximation hardness of edge dominating set problems, *Journal of Combinatorial Optimization* 11 (2006) 279-290.
- [7] M. Demange and T. Ekim, Minimum maximal matching Is NP-hard in regular bipartite graphs, *Lecture Notes in Computer Science* 4978 (2008) 364-374.
- [8] T. Fujito and H. Nagamochi, A 2-approximation algorithm for the minimum weight edge dominating set problem, *Discrete Applied Mathematics* 118 (2002) 199-207.
- [9] Z. Gotthilf, M. Lewenstein, and E. Rainshmidt, A $\left(2 - c\frac{\log n}{n}\right)$ approximation algorithm for the minimum maximal matching problem, *Lecture Notes in Computer Science* 5426 (2009) 267-278.
- [10] J.D. Horton and K. Kilakos, Minimum edge dominating sets, *SIAM Journal on Discrete Mathematics* 6 (1993) 375-387.
- [11] R. Schmied and C. Viehmann, Approximating edge dominating set in dense graphs, *Theoretical Computer Science* 414 (2012) 92-99.
- [12] M. Yannakakis and F. Gavril, Edge dominating sets in graphs, *SIAM Journal on Applied Mathematics* 38 (1980) 364-372.

Linear programming based approximation for unweighted induced matchings — breaking the Δ barrier

Julien Baste, *Maximilian Fürst*, and Dieter Rautenbach

Institute of Optimization and Operations Research, Ulm University, Germany

EXTENDED ABSTRACT

We consider finite, simple, and undirected graphs, and use standard terminology. A set M of edges of a graph G is an *induced matching* in G if no two edges in M are adjacent or joined by an edge, that is, M is an independent set of the square $L^2(G)$ of the line graph $L(G)$ of G . The *induced matching number* $\nu_s(G)$ of G is the maximum cardinality of an induced matching in G .

The problem to find a maximum induced matching in a given graph does not allow a polynomial time approximation algorithm with approximation factor $n^{1/2-\epsilon}$ for some positive ϵ , unless $P = NP$ [10], and it is APX-complete for Δ -regular bipartite graphs [1]. Several polynomial time approximation algorithms have been proposed for Δ -regular graphs: Duckworth, Manlove, and Zito [2, 12] showed that a simple greedy strategy has approximation ratio $\Delta - O(1)$. Combining the greedy strategy with local search, Gotthilf and Lewenstein [6] improved this to $0.75\Delta + 0.15$. For Δ -regular $\{C_3, C_5\}$ -free graphs, Rautenbach [11] showed that the algorithm from [6] has approximation ratio $0.708\bar{3}\Delta + 0.425$. Finally, for $\Delta = 3$, that is, for cubic graphs, Joos, Rautenbach, and Sasse [8] described a polynomial time algorithm with approximation ratio $\frac{9}{5}$. All these approximation ratios for Δ -regular graphs rely on the simple upper bound

$$\nu_s(G) \leq \frac{m(G)}{2\Delta - 1}, \quad (1)$$

which fails for not necessarily regular graphs of maximum degree Δ .

Only very recently, Lin, Mestre, and Vasiliev [9] improved the straightforward approximation ratio of $2(\Delta - 1)$ of the greedy algorithm [12] applied to a graph of maximum degree Δ . Their approach relies on linear programming and a local ratio technique. They actually consider the weighted version of the problem, and provide a polynomial time algorithm with approximation ratio Δ . As they show that the integrality gap of their integer linear programming formulation of the weighted induced matching problem is at least $\Delta - 1$, there is not much room for improvement of the approximation ratio using their approach.

In order to phrase the integer linear programming formulation of the maximum induced matching problem, we introduce some notation. Let G be a graph. For a vertex u of G , let $\delta_G(u)$ be the set of edges of G that are incident with u . For an edge uv of G , let

$$\delta_G(uv) = \delta_G(u) \cup \delta_G(v), \quad \text{and let} \quad C_G(uv) = \bigcup_{w \in N_G[u] \cup N_G[v]} \delta_G(w).$$

Note that a set M of edges in G is an induced matching in G

- if and only if $f \notin C_G(e)$ for every two distinct edges e and f in M
- if and only if $\delta_G(e)$ contains at most one edge from M for every edge e of G .

The second equivalence motivates the following (unweighted version of the) integer linear program from [9]:

$$\begin{aligned} \max \quad & \sum_{e \in E(G)} x_e \\ \text{s.t.} \quad & \sum_{f \in \delta_G(e)} x_f \leq 1 \quad \forall e \in E(G) \\ & x_e \in \{0, 1\} \quad \forall e \in E(G) \end{aligned} \quad (2)$$

Clearly, the value of (2) equals $\nu_s(G)$, and $\{e \in E(G) : x_e = 1\}$ is an induced matching for every feasible solution $(x_e)_{e \in E(G)}$ of (2). We consider the relaxation (P) of (2) together with its dual linear program (D):

$$(P) \begin{cases} \max & \sum_{e \in E(G)} x_e \\ \text{s.t.} & \sum_{f \in \delta_G(e)} x_f \leq 1 \quad \forall e \in E(G) \\ & x_e \geq 0 \quad \forall e \in E(G) \end{cases}$$

$$(D) \begin{cases} \min & \sum_{e \in E(G)} y_e \\ \text{s.t.} & \sum_{f \in \delta_G(e)} y_f \geq 1 \quad \forall e \in E(G) \\ & y_e \geq 0 \quad \forall e \in E(G) \end{cases}$$

Let $\nu_s^*(G)$ and $\tau_s^*(G)$ denote the optimum values of the linear programs (P) and (D), respectively. If $(x_e)_{e \in E(G)}$ is some feasible solution of (P) or (D), and $F \subseteq E(G)$, then let $x(F) = \sum_{e \in F} x_e$, in particular, $\sum_{f \in \delta_G(e)} x_f = x(\delta_G(e))$.

By linear programming duality,

$$\nu_s(G) \leq \nu_s^*(G) = \tau_s^*(G). \quad (3)$$

If G is Δ -regular, then setting $x_e = \frac{1}{2\Delta-1}$ for every edge e of G yields optimal solutions for (P) and (D) of value $\frac{m(G)}{2\Delta-1}$, which implies that (1) follows immediately from (3). The results of Lin et al. [9] imply that the integrality gap of the weighted version of (2) is at most Δ and at least $\Delta - 1$.

We conjecture that this can be improved considerably for unweighted graphs.

Conjecture 1 *If G is a graph of maximum degree Δ , then*

$$\frac{\nu_s^*(G)}{\nu_s(G)} \leq \begin{cases} \frac{5\Delta^2}{8\Delta-4} & , \text{ if } \Delta \text{ is even,} \\ \frac{5\Delta^3 - 21\Delta^2 + 7\Delta + 1}{8\Delta^2 - 36\Delta + 20} & , \text{ if } \Delta \text{ is odd} \end{cases} \quad (4)$$

with equality in (4) if and only if G arises by replacing the five vertices of the cycle C_5 of order five with independent sets of cardinalities $\lfloor \frac{\Delta}{2} \rfloor$, $\lfloor \frac{\Delta}{2} \rfloor$, $\lfloor \frac{\Delta}{2} \rfloor$, $\lceil \frac{\Delta}{2} \rceil$, and $\lceil \frac{\Delta}{2} \rceil$ in this cyclic order.

Note that the extremal graph in Conjecture 1 also appears in Erdős and Nešetřil's famous open conjecture on the strong chromatic index [3]. If Δ is even, then this blown-up C_5 is Δ -regular, and $\nu_s^*(G)$ equals $\frac{m(G)}{2\Delta-1} = \frac{5\Delta^2}{8\Delta-4}$. If Δ is odd, then setting

- $x_e = \frac{\Delta-5}{2\Delta^2-9\Delta+5}$ for the edges e between an independent set of order $\frac{\Delta-1}{2}$ and an independent set of order $\frac{\Delta+1}{2}$, and setting
- $x_e = \frac{\Delta-3}{2\Delta^2-9\Delta+5}$ for all remaining edges e

yields optimal solutions for (P) and (D), which explains the specific value in Conjecture 1.

Gotthilf and Lewenstein [6] obtain the approximation ratio $0.75\Delta + 0.15$ by providing a polynomial time algorithm that computes an induced matching of size at least

$$\frac{m(G)}{1.5\Delta^2 - 0.5\Delta} \quad (5)$$

in a given not necessarily regular graph G of maximum degree Δ (cf. also [5] choosing $f = 3\Delta^2/2 - \Delta/2$ and $g = 0$ in Theorem 2(ii) and in the proof of Corollary 3). For Δ -regular graphs, it follows that the integrality gap of (2) is at most $\frac{1.5\Delta^2 - 0.5\Delta}{2\Delta - 1} = \frac{3}{4}\Delta + O(1)$.

We proceed to our results. Our first result is a best-possible upper bound on the fractional induced matching number. Let T^* be the tree that arises by subdividing each edge of the star $K_{1,\Delta}$ of order $\Delta + 1$ once.

Theorem 2 *If G is a graph of maximum degree at most Δ such that no component of G has order at most 2, then $\nu_s^*(G) \leq \frac{\Delta}{2\Delta+1}n(G)$ with equality if and only if each component of G is isomorphic to T^* .*

Combining Theorem 2 with the main result from [8] yields an approximation ratio of 18/7 for subcubic graphs. Our second result improves this.

Theorem 3 *There is a polynomial time algorithm that, for a given subcubic graph G , produces an induced matching M in G as well as a feasible solution $(y_e)_{e \in E(G)}$ of (D) with $|M| \geq \frac{3}{7}y(E(G))$.*

Our final result concerns general maximum degrees.

Theorem 4 *There is a polynomial time algorithm that, for a given graph G of maximum degree at most Δ for some $\Delta \geq 3$, produces an induced matching M in G with*

$$|M| \geq \frac{\nu_s^*(G)}{(1 - \epsilon)\Delta + \frac{1}{2}} \text{ where } \epsilon \approx 0.02005.$$

The last two theorems imply, in particular, that the problem to find a maximum induced matching in the considered graphs can be approximated in polynomial time within ratios of $\frac{7}{3}$ and $(1 - \epsilon)\Delta + \frac{1}{2}$, respectively. Theorem 4 allows an interesting corollary.

Corollary 5 *If G is a graph of maximum degree at most Δ , then*

$$\nu_s(G) \geq \frac{\nu(G)}{2(1 - \epsilon)\Delta + 1} \text{ where } \epsilon \approx 0.02005,$$

where $\nu(G)$ denotes the matching number of G .

Proof: Let M be some maximum matching in G . Setting $x_e = 1/2$ for every edge e in M , and $x_e = 0$ otherwise, yields a feasible solution of (P). This implies $\nu_s^*(G) \geq x(E(G)) = |M|/2$. Now, Theorem 4 implies the statement. \square

References

- [1] K.K. Dabrowski, M. Demange, V.V. Lozin, New results on maximum induced matchings in bipartite graphs and beyond, *Theoretical Computer Science* 478 (2013) 33-40.
- [2] W. Duckworth, D.F. Manlove, M. Zito, On the approximability of the maximum induced matching problem, *Journal of Discrete Algorithms* 3 (2005) 79-91.
- [3] R.J. Faudree, R.H. Schelp, A. Gyarfas, Zs. Tuza, Induced matchings in bipartite graphs, *Discrete Mathematics* 78 (1989) 83-87.
- [4] Z. Furedi, F. Lazebnik, A. Seress, V.A. Ustimenko, A.J. Woldar, Graphs of prescribed girth and bi-degree, *Journal of Combinatorial Theory, Series B* 64 (1995) 228-239.
- [5] M. Furust, M. Leichter, D. Rautenbach, Locally searching for large induced matchings, *Theoretical Computer Science* 720 (2018) 64-72.

- [6] Z. Gotthilf, M. Lewenstein, Tighter approximations for maximum induced matchings in regular graphs, *Lecture Notes in Computer Science* 3879 (2006) 270-281.
- [7] F. Joos, Induced matchings in graphs of bounded degree, *SIAM Journal on Discrete Mathematics* 30 (2016) 1876-1882.
- [8] F. Joos, D. Rautenbach, T. Sasse, Induced matchings in subcubic graphs, *SIAM Journal on Discrete Mathematics* 28 (2014) 468-473.
- [9] M.C. Lin, J. Mestre, S. Vasiliev, Approximating weighted induced matchings, *Discrete Applied Mathematics* 243 (2018) 304-310.
- [10] Y. Orlovich, G. Finke, V. Gordon, I. Zverovich, Approximability results for the maximum and minimum maximal induced matching problems, *Discrete Optimization* 5 (2008) 584-593.
- [11] D. Rautenbach, Two greedy consequences for maximum induced matchings, *Theoretical Computer Science* 602 (2015) 32-38.
- [12] M. Zito, Induced matchings in regular graphs and trees, *Lecture Notes in Computer Science* 1665 (1999) 89-101.

Bounding the broadcast domination number by the multipacking number

Laurent Beaudou ¹, Richard Brewster ², Florent Foucaud ³, Bohdana Mitchell ²

¹ Higher School of Economics, Moscow, Russian Federation

² Math and Stats, Thompson Rivers University, Canada

³ LaBRI, University of Bordeaux, France

EXTENDED ABSTRACT

The dual concepts of coverings and packings are well studied in graph theory, see [5]. Coverings of graphs with balls of radius one and packings of vertices with pairwise distances at least two are the well-known concepts of domination and independence respectively, see [10]. Typically we are interested in minimum (cost) coverings and maximum (weight) packings. Two natural questions to ask are the following: For what graphs do these dual problems have equal (integer) values? In the case of non-equality, can we bound the difference between the two values? The second question is the focus of this work.

The particular covering problem we study is broadcast domination. Let $G = (V, E)$ be a graph. Define the *ball of radius r around v* by

$$N_r[v] = \{u : d(u, v) \leq r\}.$$

A *dominating broadcast* of G is a collection of balls $N_{r_1}[v_1], N_{r_2}[v_2], \dots, N_{r_t}[v_t]$ (each $r_i > 0$) such that $\bigcup_{i=1}^t N_{r_i}[v_i] = V$. Alternatively, a dominating broadcast is a function $f : V \rightarrow \mathbb{N}$ such that for any vertex $u \in V$, there is a vertex $v \in V$ with $f(v) > 0$ and $\text{dist}(u, v) \leq f(v)$. A vertex v with $f(v) > 0$ can be thought of as the site from which the broadcast is transmitted with power $f(v)$. The ball $N_{f(v)}[v]$ is the set of vertices that hear the broadcast from v . (The ball $N_{f(v)}[v]$ belongs to the covering.) Vertices u for which $f(u) = 0$ do not broadcast and the trivial ball $N_0[u]$ is not included in the cover.

The *cost* of a dominating broadcast f is $\sum_{v \in V} f(v)$. The minimum cost of a dominating broadcast in G (taken over all dominating broadcasts) is the *broadcast domination number* of G , denoted by $\gamma_b(G)$.

The broadcast domination number can be defined as an integer linear program:

$$\gamma_b(G) = \min\{cx \mid x_{(i,k)} \in \{0, 1\}, Ax \geq \mathbf{1}\}$$

where the vectors c, x and the columns of A are indexed by (i, k) for $i \in V(G)$ and $1 \leq k \leq \text{diam}(G)$. The entry $c_{(i,k)} = k$. The entry $x_{(i,k)} = 1$ if and only if $N_k[i]$ is in the dominating broadcast, i.e. $f(i) = k$. Finally, the matrix $A = [a_{j,(i,k)}]$ is defined by $a_{j,(i,k)} = 1$ if vertex j belongs to $N_k[i]$ in G and is zero otherwise.

The dual to this problem is the *maximum multipacking problem* [3, 14]. A *multipacking* in a graph G is a subset $P \subseteq V(G)$ such that for any positive integer r and any vertex v in V , the ball of radius r centred at v contains at most r vertices of P . The maximum size of a multipacking of G , its *multipacking number*, is denoted by $\text{mp}(G)$. That is,

$$\text{mp}(G) = \max\{y\mathbf{1} \mid y_j \in \{0, 1\}, yA \leq c\}.$$

In this work our bounds are based on the diameter of the graph in question. Hence, we restrict our attention to connected graphs with the observation that disconnected graphs can be studied component-wise.

Broadcast domination was introduced by Erwin [6, 7] in his doctoral thesis in 2001. Multipacking was then defined by Teshima in her Master's Thesis [14] in 2012, see also [3] (and [4, 9, 15] for subsequent studies). This work fits into the general study of coverings and packings, which has a rich history in Graph Theory: Cornuéjols wrote a monograph on the topic [5].

In early work, Meir and Moon [13] studied various coverings and packings in trees, providing several inequalities relating the size of a minimum covering and a maximum packing. Giving such inequalities connecting the parameters γ_b and mp is the focus of our work. Since broadcast domination and multipacking are dual problems, we know that for any graph G ,

$$\text{mp}(G) \leq \gamma_b(G).$$

This bound is tight, in particular for strongly chordal graphs, see [8, 12, 14]. (In a recent companion work we prove equality for grids [2].) A natural question comes to mind. How far apart can these two parameters be? Hartnell and Mynhardt [9] gave a family of connected graphs $(G_k)_{k \in \mathbb{N}}$ for which the difference between both parameters is k . In other words, the difference can be arbitrarily large. Nonetheless, they proved the ratio is bounded as follows.

For any connected graph G , a diametrical path is an isometric path. It follows that a multipacking of the diametrical path is also a multipacking in G . Since $\text{mp}(P_n) = \lceil n/3 \rceil$, we obtain

$$\text{mp}(G) \geq \left\lceil \frac{\text{diam}(G) + 1}{3} \right\rceil$$

Pairing this with the observation $\gamma_b(G) \leq \text{rad}(G)$ (see [6]), and some further analysis, they proved for any connected graph G with $\text{mp}(G) \geq 2$,

$$\gamma_b(G) \leq 3\text{mp}(G) - 2.$$

They then asked [9, Section 5] whether the factor 3 can be improved. Answering their question in the affirmative, our main result is the following.

Theorem 1 *Let G be a connected graph. Then,*

$$\gamma_b(G) \leq 2\text{mp}(G) + 3.$$

Moreover, we conjecture that the additive constant in the bound of Theorem 1 can be removed.

Conjecture 2 *For any connected graph G , $\gamma_b(G) \leq 2\text{mp}(G)$.*

Through a further refinement of the methods in [9], we establish Conjecture 2 holds for small values of mp.

Theorem 3 *Let G be a connected graph. If $\text{mp}(G) \leq 4$, then $\gamma_b(G) \leq 2\text{mp}(G)$.*

We know a few examples of connected graphs G which achieve the conjectured bound, that is, $\gamma_b(G) = 2\text{mp}(G)$. For example, one can easily check that C_4 and C_5 have multipacking number 1 and broadcast number 2. We know of connected examples having multipacking number 2 and domination broadcast number 4. By taking disjoint unions of these graphs, we can build further extremal graphs with arbitrary multipacking number. However, if we only consider connected graphs, we do not even know an example with multipacking number 3 and domination broadcast number 6. Hartnell and Mynhardt [9] constructed an infinite family of connected graphs G with $\gamma_b(G) = \frac{4}{3}\text{mp}(G)$, but we do not know any construction with a higher ratio. Are there arbitrarily large connected graphs that reach the bound of Conjecture 2?

Finally, we note that while computing γ_b can be done in polynomial time [11], the computation complexity of computing mp remains open. Our proofs are constructive. In particular, given a connected graph G , we construct a multipacking of size at least $\frac{\text{mp}(G)-3}{2}$. Consequently, our work provides a $(2 + o(1))$ -approximation algorithm for mp.

References

- [1] L. Beaudou, R. C. Brewster, and F. Foucaud, Broadcast domination and multipacking: bounds and the integrality gap, *Aust. J. Comb.*, **74** (2019), 86–97.
- [2] L. Beaudou and R. C. Brewster, On the multipacking number of grid graphs, *Disc. Math. Theor. Comp Sci.* **21** (2019)
- [3] R. C. Brewster, C. M. Mynhardt and L. Teshima, New bounds for the broadcast domination number of a graph, *Cent. Eur. J. Math.*, **11** (2013), 1334–1343.
- [4] R. C. Brewster, G. MacGillivray and F. Yang, Broadcast domination and multipacking in strongly chordal graphs, *Discrete Appl. Math.*, **261** (2019), 108–118.
- [5] G. Cornuéjols. *Combinatorial Optimization: packing and covering*. CBMS-NSF regional conference series in applied mathematics, vol. 74. Society for Industrial and Applied Mathematics (SIAM), Philadelphia, 2001.
- [6] D. J. Erwin, *Cost domination in graphs*, PhD Thesis, Department of Mathematics, Western Michigan University, 2001.
- [7] D. J. Erwin, Dominating broadcasts in graphs, *Bull. Inst. Combin. Appl.*, **42** (2004), 89–105.
- [8] M. Farber, Domination, Independent Domination, and Duality in Strongly Chordal Graphs, *Discrete Appl. Math.*, **7** (1984), 115–130.
- [9] B. L. Hartnell and C. M. Mynhardt, On the difference between broadcast and multipacking numbers of graphs, *Util. Math.*, **94** (2014), 19–29.
- [10] T. W. Haynes, S. T. Hedetniemi, and P. J. Slater, Fundamentals of domination in graphs. *Monographs and Textbooks in Pure and Applied Mathematics*, 208. Marcel Dekker, Inc., New York, 1998.
- [11] P. Heggernes and D. Lokshtanov, Optimal broadcast domination in polynomial time, *Discrete Math.*, **306** (2006), 3267–3280.
- [12] A. Lubiw, Doubly Lexical Orderings of Matrices, *SIAM J. Comput.*, **16** (1987), 854–879.
- [13] A. Meir and John W. Moon, Relations between packing and covering numbers of a tree, *Pacific J. Math.*, **61** (1975), 225–233.
- [14] L. Teshima, *Broadcasts and multipackings in graphs*, Master’s Thesis, Department of Mathematics and Statistics, University of Victoria, 2012.
- [15] F. Yang, *New results on broadcast domination and multipacking*, Master’s Thesis, Department of Mathematics and Statistics, University of Victoria, 2015.

Bounds on Broadcast Independence

Stéphane Bessy ¹ and Dieter Rautenbach ²

¹ Laboratoire d'Informatique, de Robotique et de Microélectronique de Montpellier,
Université Montpellier, France

² Institute of Optimization and Operations Research, Ulm University, Germany

EXTENDED ABSTRACT

In his PhD thesis [8] Erwin introduced the notions of broadcast domination and broadcast independence in graphs, cf. also [7]. While broadcast domination was studied in detail [6, 9, 10, 11, 12, 13], only little research exists on broadcast independence [1, 5]. In the present paper we relate broadcast independence to ordinary independence in graphs; one of the most fundamental and well studied notions in graph theory.

We consider finite, simple, and undirected graphs, and use standard terminology and notation. Let \mathbb{N}_0 be the set of nonnegative integers. For a connected graph G , a function $f : V(G) \rightarrow \mathbb{N}_0$ is an *independent broadcast on G* if

(B1) $f(x) \leq \text{ecc}_G(x)$ for every vertex x of G , where $\text{ecc}_G(x)$ is the eccentricity of x in G , and

(B2) $\text{dist}_G(x, y) > \max\{f(x), f(y)\}$ for every two distinct vertices x and y of G with $f(x), f(y) > 0$, where $\text{dist}_G(x, y)$ is the distance of x and y in G .

The *weight* of f is $\sum_{x \in V(G)} f(x)$. The *broadcast independence number* $\alpha_b(G)$ of G is the maximum weight of an independent broadcast on G , and an independent broadcast on G of weight $\alpha_b(G)$ is *optimal*. Let $\alpha(G)$ be the usual independence number of G , that is, $\alpha(G)$ is the maximum cardinality of an independent set in G , which is a set of pairwise nonadjacent vertices of G . For an integer k , let $[k]$ be the set of all positive integers at most k , and let $[k]_0 = \{0\} \cup [k]$.

Clearly, assigning the value 1 to every vertex in an independent set in some connected graph G , and 0 to all remaining vertices of G , yields an independent broadcast on G , which implies

$$\alpha_b(G) \geq \alpha(G) \text{ for every connected graph } G.$$

A consequence of our main result is that $\alpha_b(G) \leq 4\alpha(G)$ for every connected graph G . The fact that the broadcast independence number and the independence number are within a constant factor from each other immediately implies the computational hardness of the broadcast independence number, and also yields efficient constant factor approximation algorithms for the broadcast independence number on every class of graphs for which the independence number can efficiently be approximated within a constant factor.

We completely describe two infinite classes of graphs \mathcal{G}_2 and \mathcal{G}_0 illustrated in Figure 1 and Figure 2, and prove the following result.

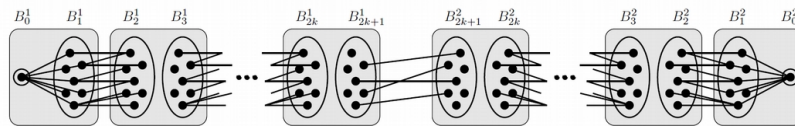

Figure 1: A graph from the family \mathcal{G}_2 . The vertices in each gray box form a clique.

Theorem 1 *If G is a connected graph such that G has diameter at least 3 or $\alpha(G) \geq 3$, and f is an optimal broadcast on G , then*

$$\alpha_b(G) \leq 4\alpha(G) - 4 \min \left\{ 1, \frac{2\alpha(G)}{f_{\max} + 2} \right\}, \quad (1)$$

where $f_{\max} = \max\{f(x) : x \in V(G)\}$. Equality holds in (1) if and only if $G \in \mathcal{G}_0 \cup \mathcal{G}_2$.

The assumption that G has diameter at least 3 or $\alpha(G) \geq 3$ excludes some trivial cases.

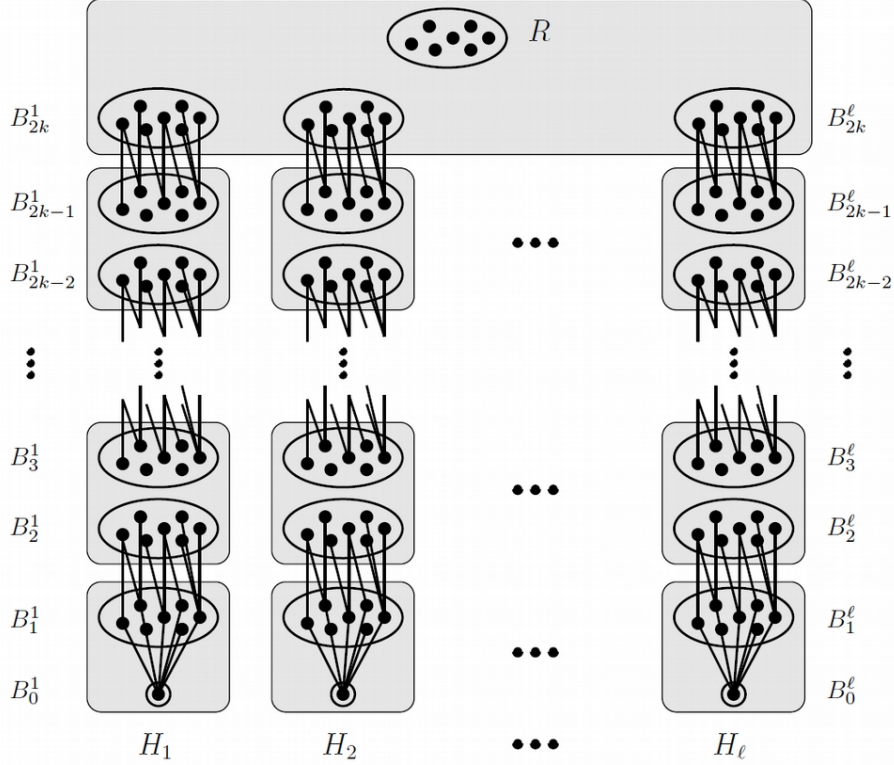

Figure 2: A graph from the family $\mathcal{G}_0(k, \ell)$. Also here, the vertices in each gray box form a clique.

Theorem 1 implies

$$1 \leq \frac{\alpha_b(G)}{\alpha(G)} \leq 4$$

for every connected graph G . Its proof suggests that $\frac{\alpha_b(G)}{\alpha(G)}$ should be smaller than 4 for connected graphs G of sufficiently large local expansion and sparsity. Natural hypotheses ensuring these properties are lower bounds on the girth and the minimum degree. In this direction, we show the following two results.

Theorem 2 *If G is a connected graph of girth at least 6 and minimum degree at least 3, then*

$$\alpha_b(G) < 2\alpha(G).$$

Theorem 3 *For every positive integer k , there is a connected graph G of girth at least k and minimum degree at least k such that*

$$\alpha_b(G) \geq 2 \left(1 - \frac{1}{k}\right) \alpha(G).$$

Together, the last two results imply that lower bounds on the girth and the minimum degree of a connected graph G can lower the fraction $\frac{\alpha_b(G)}{\alpha(G)}$ from 4 below 2, but not any further.

References

- [1] M. Ahmane, I. Bouchemakh, E. Sopena, On the broadcast independence number of caterpillars, *Discrete Applied Mathematics* 244 (2018) 20-35.
- [2] S. Bessy, D. Rautenbach, Girth, minimum degree, independence, and broadcast independence, *Commun. Comb. Optim.* 4 (2019), 131-139.
- [3] S. Bessy, D. Rautenbach, Algorithmic aspects of broadcast independence, arXiv:1809.07248.
- [4] S. Bessy, D. Rautenbach, Relating broadcast independence and independence, arXiv:1809.09288.
- [5] I. Bouchemakh, M. Zemir, On the broadcast independence number of grid graph, *Graphs and Combinatorics* 30 (2014) 83-100.
- [6] R.C. Brewster, C.M. Mynhardt, L.E. Teshima, New bounds for the broadcast domination number of a graph, *Central European Journal of Mathematics* 11 (2013) 1334-1343.
- [7] J.E. Dunbar, D.J. Erwin, T.W. Haynes, S.M. Hedetniemi, S.T. Hedetniemi, Broadcasts in graphs, *Discrete Applied Mathematics* 154 (2006) 59-75.
- [8] D.J. Erwin, Cost domination in graphs, (Ph.D. thesis), Western Michigan University, 2001.
- [9] P. Heggenes, D. Lokshantov, Optimal broadcast domination in polynomial time, *Discrete Mathematics* 36 (2006) 3267-3280.
- [10] S. Herke, C.M. Mynhardt, Radial Trees, *Discrete Mathematics* 309 (2009) 5950-5962.
- [11] S. Lunney, C.M. Mynhardt, More trees with equal broadcast and domination numbers, *Australasian Journal of Combinatorics* 61 (2015) 251-272.
- [12] S.M. Seager, Dominating broadcasts of caterpillars, *Ars Combinatorica* 88 (2008) 307-319.
- [13] K.W. Soh, K.M. Koh, Broadcast domination in graph products of paths, *Australasian Journal of Combinatorics* 59 (2014) 342-351.

Triangle-free graphs with large packing chromatic number

*Ez-Zobair BIDINE*¹ and *Mustapha KCHIKECH*²

¹ Faculty of Sciences and Technics of Settat, Hassan 1st University, Morocco

² Poly-disciplinary Faculty of Safi, Caadi Ayad University, Morocco

EXTENDED ABSTRACT

A k -packing coloring of a graph G with vertex set V , for some integer k , is a mapping $f : V \rightarrow \{1, 2, \dots, k\}$ such that for any two distinct vertices u and v from V : if $f(u) = f(v) = i$, then $d_G(u, v) > i$, where $d_G(u, v)$ is the distance between u and v in G . The packing chromatic number $\chi_\rho(G)$ of a graph G is the smallest integer k such that the graph G has a k -packing coloring [1]. A k -packing colorable graph is a graph such that $\chi_\rho(G) \leq k$. The decision problem related to computing the packing chromatic number is \mathcal{NP} -hard in general. The boundness of the packing chromatic number was the subject of most papers investigating this parameter. The number $|G| - \alpha(G) + 1$ is a famous upper bound of $\chi_\rho(G)$ for any graph G of order $|G|$ where $\alpha(G)$ is the independence number of a graph G [1]. But the independence number problem is also known to be \mathcal{NP} -hard in general. It is interesting to generate graphs which packing chromatic number can be controlled. In this paper, we show that any graph G of order $|G|$ can be transformed into a graph $f(G)$ (via some transformation f) such that $\chi_\rho(f(G)) \in \mathcal{O}(|G|)$.

The neighborhood of every vertex in triangle-free graphs is an independent set, but there may exist maximum independent sets that are not neighborhoods of vertices. Then, in such graphs, it is evident that

$$\Delta(G) \leq \alpha(G) \tag{1}$$

A graph is maximal triangle-free if no edge may be added without producing a triangle. In this paper we prove the existence of a class of maximal triangle-free (and then of diameter 2) graphs satisfying (1) with equality and with large packing chromatic number. The existence of class of maximal triangle-free graphs with large packing chromatic number satisfying $\chi_\rho = \Delta = \alpha = \chi'$ will be also proved, where Δ and χ' stands for the maximum degree and the edge-chromatic number respectively.

1 Notations and Preliminary results

Recall first the following result presenting an upper bound of the packing chromatic numbers.

Proposition 1 ([1]). *If G is a graph with order $|G|$, then*

$$\chi_\rho(G) \leq |G| - \alpha(G) + 1 \tag{2}$$

with equality if $\text{diam}(G) = 2$.

Many are papers investigating the boundness of the packing chromatic number from above by a constant for several classes of graphs. This question for the class of subcubic graphs was answered in the negative [10] after being considered in recent works [11, 12, 13].

Most of the proposed constructions in this paper are based on Mycielski's graphs. The Mycielski's theorem gives the existence of triangle-free graphs with arbitrarily large chromatic numbers [3]. Given a graph $G = (V(G), E(G))$, the *Mycielski graph* of G is the graph, denoted by $\mu(G)$, with the vertex set $V(\mu(G)) = V(G) \cup V'(G) \cup \{z\}$ and the edge set $E(\mu(G)) = E(G) \cup \{uv' : uv \in E(G)\} \cup \{v'z : v' \in V'\}$ where $V'(G) = \{u' : u \in V\}$. A vertex v' from $V'(G)$ is called a twin (or copy) of v . The vertex z is called the root of $\mu(G)$. Recall

that $\omega(\mu(G)) = \omega(G)$ and $\chi(\mu(G)) = \chi(G) + 1$ are two nice properties of this transformation. The *iterated Mycielskian* of a graph G , denoted $\mu^p(G)$ for $p \geq 1$, is the transformation of G defined by $\mu^0(G) = G$ and $\mu^p(G) = \mu(\mu^{p-1}(G))$. If such transformation is applied on a triangle-free graph G , then the obtained graph $\mu^p(G)$ is also a triangle-free graph (by induction on p). The Mycielskians were investigated from many points of view [5, 6, 7, 4, 8, 9]. Note that $|\mu^p(G)| = 2^p(1 + |G|) - 1$.

Recall the that the diameter of the Mycielskian of a graph is given by :

Theorem 2 ([2]). *For a graph G without isolated vertices,*

$$\text{diam}(\mu(G)) = \min \{ \max \{ 2, \text{diam}(G) \}, 4 \}$$

Let introduce the next definition, which we shall use in the next section.

Definition 3. *Let k be a positive integer. A graph G is said \mathcal{T} - k -graph if there exists a transformation f of G such that the obtained graph $f(G)$ is k -packing colorable. If $\chi_\rho(f(G)) = k$, then G is said \mathcal{T}_ρ - k -graph.*

2 \mathcal{T} - k -graphs

We will focus on graphs G that are \mathcal{T} - k -graphs where k is a positive integer satisfying $k \in \mathcal{O}(|G|)$.

Theorem 4. *Every connected graph G with diameter at least 4 is a \mathcal{T} - $(|G| - 1)$ -graph. Moreover, every triangle-free graph G is a \mathcal{T}_ρ - $(|G| - 1)$ -graph.*

Theorem 5. *Every graph G with diameter at least 3 is a \mathcal{T} - $(|G| + 1)$ -graph.*

The graph P_4 graph is \mathcal{T}_ρ - $(|P_4| + 1)$ -graph. In deed $\chi_\rho(\mu(P_4)) = 5 = 1 + |P_4|$.

Theorem 6. *Every (non empty) graph G is a \mathcal{T} - $2|G|$ -graph. Moreover, every triangle-free graph G is a \mathcal{T}_ρ - $2|G|$ -graph.*

3 Triangle-free graphs with large packing chromatic number

By applying the theorem 2, several times on successive iterated mycielskian of a graph with diameter two, each iterated mycielskian of G is also a triangle-free graph.

Let G be a graph and i be a positive integer and let $\mu^i(G)$ be the i^{th} iterated mycielskian of G with $V(\mu^i(G)) = V(\mu^{i-1}(G)) \cup V'(\mu^{i-1}(G)) \cup \{z_i\}$. Let x be a vertex from $V(\mu^i(G))$.

The degree of x in $\mu^i(G)$ can be given as follows

$$d_{\mu^i(G)}(x) = \begin{cases} 2d_{\mu^{i-1}(G)}(x) & , \text{if } x \in V(\mu^{i-1}(G)) \\ 1 + d_{\mu^{i-1}(G)}(u) & , \text{if } x \in V'(\mu^{i-1}(G)) \text{ where } x = u' \text{ and } u \in V(\mu^{i-1}(G)) \\ 2^{i-1}(1 + |G|) - 1 & , x = z_i \end{cases}$$

We will need the following lemma :

Lemma 7. *If G is a graph such that $2\Delta(G) > |G|$, then for any positive integer i we have :*

$$\Delta(\mu^i(G)) = 2^i \Delta(G)$$

Next, is the main theorem of this section :

Theorem 8. *For any positive integers $p \geq 1$ and $n \geq 2$, there exists a maximal triangle-free graph $H_{p,n}$ such that :*

1. $\alpha(H_{p,n}) = \Delta(H_{p,n}) = 2^p \cdot n$
2. $\chi_\rho(H_{p,n}) = 2^{p+1}$

The edge-chromatic number $\chi'(G)$ of a graph G is the chromatic number of its line graph. In 1964, Vizing [14] showed that every graph G has edge-chromatic number either $\Delta(G)$ (known as Class I graphs) or $\Delta(G) + 1$ (known as Class II graphs). Deciding the class of a given graph is \mathcal{NP} -complete for general graphs [16]. It was shown in [15] that the Mycielski graph of a graph G is class I except for $G = K_2$. It follows by successive mycielski construction that :

Proposition 9. *For any positive integer $p \geq 1$ and any graph G other than K_2 , the iterated Mycielskian graph $\mu^p(G)$ of G is class I. And then $\chi'(\mu^p(G)) = \Delta(\mu^p(G))$. Moreover, if $2\Delta(G) > |G|$, then $\chi'(\mu^p(G)) = 2^p \chi'(G)$.*

An immediate result from theorems 8 and 9 is :

Corollary 10. *For any positive integer $p \geq 1$, there exists a class of graphs G_p such that*

$$\Delta(G_p) = \alpha(G_p) = \chi_\rho(G_p) = \chi'(G_p) = 2^{p+1}$$

References

- [1] W.Goddard, S.M. Hedetniemi, S.T. Hedetniemi, J M. Harris; and D.F. Rall. Broadcast chromatic numbers of graphs. **Ars Combinatoria**, 86:33-50, 2008.
- [2] D.C. Fisher, P.A Mckenna, and E.D. Boyer. Hamiltonicity, diameter, domination, packing, and biclique partitions of mycielski's graphs. **Elsevier**, 1997.
- [3] J. Mycielski. Sur le coloriage des graphes. *Colloq. Math*, 3:161–162, 1955.
- [4] G.J Change, L. Huang and W. Zhu. Circular chromatic numbers of Mycielski's graphs **Discrete Mathematics**, 205:23–37, 1999.
- [5] T. Doslic. Mycielskians and matchings. **Discuss. Math. Graph Theory**, 25(3): 261–266, 2005.
- [6] L. Guo, R. Liu, and X. Guo. Super connectivity and super edge connectivity of the mycielskian of a graph. **Graphs and Combinatorics**, 28(2):143–147, 2012.
- [7] L. Huang and G.J Chang. The circular chromatic number of the mycielskian of G_k^d . **Journal of Graph Theory**, 32(1), 63-71, 1999.
- [8] W .Lin, D.D-F Liu, and X. Zhu. Multi-coloring the mycielskian of graphs. **Journal of Graph Theory**, 63(4):311–323, 2010.
- [9] W. Lin, J. Wu, P.C.B Lam, and G. Gu. Several parameters of generalized mycielskians. **Discrete Applied Mathematics**, 154(8):1173-1182, 2006.
- [10] J. Balogh, A. Kostachka, and X. Liu. Packing chromatic number of cubic graphs. **Discrete Mathematics**, 341(2):474–483, 2018.

- [11] B. Brešar, S. Klavžar, and D.F. Rall. Packing chromatic number of base-3 sierpinski graphs. **Graphs combin**, 32, 2016.
- [12] B. Brešar, S. Klavžar, D.F. Rall, and K. Wash. Packing chromatic number under local changes in a graph. **Discrete Mathematics**, 340:1110–1115, 2017.
- [13] N. Gastineau and O. Togni. S-packing colorings of cubic graphs. **Discrete Mathematics**, 339:2461–2470, 2016.
- [14] V.G. Vizing. On an estimate of the chromatic class of a p-graph. **Discret Analiz**, 3:25–30, 1964.
- [15] Y.S. Kwon, J. Lee, and Z. Zhongfu. Edge-chromatic numbers of mycielski graphs. **Discrete Mathematics**, 312(6):1222–1225, 2012.
- [16] I. Holyer. The np-completeness of edge-coloring. **SIAM Journal on computing**, 10(4):718–720, 1981.
- [17] A. Aazami, M. D. Stip. Approximation algorithms and hardness for domination with propagation. **SIAM J. Discrete Math.** 23:1382–1399, 2009.
- [18] B. Brešar and J. Ferme. Graphs that are critical for the packing chromatic number. **arXiv preprint arXiv:1904.10212**, 2019.

Optimizing dominating sets under constrained transformation

Alexandre Blanché¹, Haruka Mizuta², Paul Ouvrard¹ and Akira Suzuki²

¹ LaBRI-CNRS, University of Bordeaux, France

² Graduate School of Information Sciences, Tohoku University, Sendai, Japan

EXTENDED ABSTRACT

Dominating set reconfiguration. A *dominating set* in a graph G is a subset D of vertices of G such that any vertex in the graph is either in D or a neighbor of a vertex of D . We are interested in *reconfiguring* ([3], [4]) dominating sets: given a dominating set D , we can obtain another one by adding or deleting one vertex from D . By using only these operations and without getting above a certain bound on the size of the set, which dominating sets are reachable from the initial one?

More formally, we say that a $\text{TAR}(k)$ *sequence* between two dominating sets D and D' is a sequence $D = D_0, D_1, \dots, D_m = D'$ of dominating sets such that each intermediate set is obtained from the previous one by addition or removal of one vertex, and $|D_i| \leq k$ for all i . The *Dominating set reconfiguration reachability problem* REACH-DSR is defined as follows: given a graph G , a bound $k \in \mathbb{N}$ and two dominating sets D, D' , is there a $\text{TAR}(k)$ sequence between D and D' ? If there exists such a sequence, we say that D' is *reachable* from D under the $\text{TAR}(k)$ rule (and vice-versa).

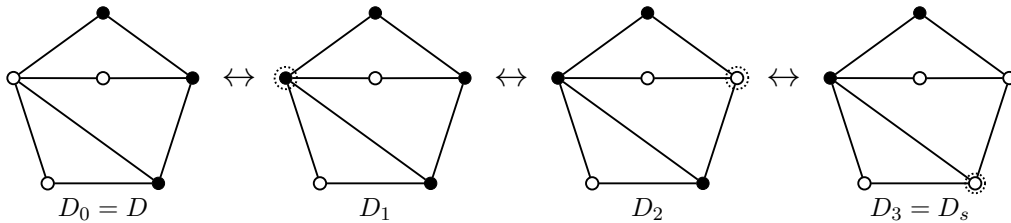

Figure 1: An example of reconfiguration sequence between D_0 and D_3 via dominating sets D_1, D_2 with upper bound $k = 4$, where vertices contained in a dominating set are depicted by colored circles, and added or removed vertices are surrounded by dotted circles.

The goal of reconfiguration, in particular of dominating sets, is usually to find a better solution of our problem ; in this case a dominating set which has fewer vertices than the original one. Based on this idea, Ito *et al* introduced a new framework of reconfiguration problems [7]. In this variant called OPT-ISR, for *Optimization variant of Independent set reconfiguration*, we are only given an initial solution, in this case an independent set, and the goal is to find a better solution that is reachable from the initial one through reconfiguration steps, again while staying above (in the case of a maximization problem) a certain bound. Since the dominating set reconfiguration is well studied ([1], [2], [5]), we chose to focus on the optimization variant OPT-DSR of the dominating set reconfiguration problem.

OPT-DSR

- **Input:** A graph G , an upper bound $k \in \mathbb{N}$, a desired bound $s \in \mathbb{N}$ and a dominating set D_0 of G , such that $|D_0| \leq k$.
- **Question:** Is there dominating set D_t of G , reachable from D_0 under the $\text{TAR}(k)$ rule and such that $|D_t| \leq s$?

We study the complexity of the problem both in terms of polynomial-time (in)tractability and fixed-parameter (in)tractability.

Polynomial-time (in)tractability We first observe that OPT-DSR generalizes the classical *minimum dominating set problem*, which is known to be NP-complete [6]. Hence we deduce this first complexity result:

Theorem 1 *OPT-DSR is NP-hard.*

More precisely, we can prove that the problem is in fact PSPACE-complete, even on three classes of graphs: bounded pathwidth graphs, split graphs and bipartite graphs. A *split graph* is a graph whose vertices can be partitioned into a clique and an independent set.

Theorem 2 *OPT-DSR is PSPACE-complete even for bounded pathwidth graphs, for split graphs, and for bipartite graphs.*

For bounded pathwidth and split graphs, we prove the theorem by giving a polynomial-time reduction from the optimization variant of *Vertex cover reconfiguration*, OPT-VCR, which is the equivalent of OPT-DSR in terms of vertex covers. OPT-VCR is known to be PSPACE-complete even for graphs with bounded pathwidth [7]. For bipartite graphs, we give a polynomial-time reduction from OPT-DSR on split graphs.

On the other hand, we are able to solve in polynomial time the problem on the class of *interval graphs*, which are the graphs that represent the contacts within a set of intervals of \mathbb{R} . We provide a polynomial-time algorithm for these graphs.

Theorem 3 *OPT-DSR is polynomial-time solvable for interval graphs.*

Fixed-parameter tractability We then study the fixed-parameter complexity of OPT-DSR. First, we consider *d-degenerate* graphs, i.e. the ones which can be built by only adding vertices of degree at most d at each step. Our first result states that the problem is fixed-parameter tractable (FPT) with respect to the degeneracy d and the solution size s .

Theorem 4 *OPT-DSR is fixed-parameter tractable when parameterized by $d + s$.*

To prove it, we provide an FPT algorithm using the idea of *domination core* introduced by Lokshtanov *et al* [5].

Finally, we prove that OPT-DSR is FPT with respect to the size τ of a minimum vertex cover.

Theorem 5 *OPT-DSR is fixed-parameter tractable when parameterized by the size τ of a smallest vertex cover.*

To prove it, we observe that if $\tau > s$, then we can use the $\text{FPT}(d + s)$ algorithm, and in the case $\tau \leq s$ we provide an algorithm that solves the problem in time $\text{FPT}(\tau)$.

References

- [1] A. Suzuki and A.E. Mouawad and N. Nishimura. Reconfiguration of dominating sets. **Journal of Combinatorial Optimization**, 32(4):1182–1195, 2016.
- [2] A. Haddadan and T. Ito and A.E. Mouawad and N. Nishimura and H. Ono and A. Suzuki and Y. Tebbal. The complexity of dominating set reconfiguration. **Theoretical Computer Science**, 651:37–49, 2016.
- [3] N. Nishimura. Introduction to reconfiguration. **Algorithms**, 11(4):52, 2018.
- [4] J. van den Heuvel. The complexity of change. **Surveys in Combinatorics 2013**, volume 409 of **London Mathematical Society Lecture Note Series**, pages 127–160. Cambridge University Press, 2013.
- [5] D. Lokshtanov, A.E. Mouawad, F. Panolan, M.S. Ramanujan and S. Saurabh. Reconfiguration on sparse graphs. **J. Comput. Syst. Sci.**, 95:122–131, 2018.
- [6] M.R. Garey and D.S. Johnson. *Computers and Intractability: A Guide to the Theory of NP-Completeness*. Freeman, San Francisco, CA, 1979.
- [7] T. Ito, H. Mizuta, N. Nishimura, A. Suzuki. Incremental optimization of independent sets under reachability constraints. To appear in **Proceedings of the 25th International Computing and Combinatorics Conference (COCOON 2019)**.

Smaller Induced-Universal Graph for Planar Graphs

Marthe Bonamy¹, Cyril Gavoille¹, and Michał Pilipczuk²

¹ LaBRI-CNRS, University of Bordeaux, France

² Institute of Informatics, University of Warsaw, Poland

EXTENDED ABSTRACT

A graph \mathcal{U} is an induced-universal graph for a given family of graphs \mathcal{F} if every graph of \mathcal{F} is isomorphic to an induced-subgraph of \mathcal{U} . A challenging question is to construct induced-universal graphs of smallest size, i.e., with the minimum number of vertices. We construct an induced-universal graph of size $n^{4/3+o(1)}$ for the family of all n -vertex planar graphs. This is the first sub-quadratic bound for planar graphs. Our construction generalizes to the family of graphs of Euler genus at most g . The size of the universal graph is the same, up to a lower-order term depending on g .

Our construction is based on a shorter implicit representation of planar graphs. We show how to assign to each label of any planar graph a label of $\frac{4}{3} \log n + O(\log \log n)$ bits such that adjacency between any two vertices can be decided by a fixed procedure that examines only their labels.

1 Introduction

In standard graph representations, such as with adjacency lists and matrices, vertex identifiers do not play any particular role with respect to the structure of the graph: they are essentially just pointers in the data structure. On the contrary, *implicit representation* associates with each vertex of the graph more information so that adjacency, for instance, can be efficiently determined from these pieces of information, without the need of any global data-structure. For instance, if G is an interval graph with n vertices, one can associate with each vertex u some interval $I(u) \subseteq [1, 2n]$ with integer endpoints so that u, v are adjacent if and only if $I(u) \cap I(v) \neq \emptyset$. Clearly, no adjacency lists or matrices are required anymore. Although G may have a quadratic number of edges, such an implicit representation uses $2 \log n + O(1)$ bits per vertex¹, regardless of its degree. Compact representations have several advantages, not only for the memory storage, but also from algorithmic perspectives. For instance, given a succinct representation, BFS traversal can be done in $O(n)$ time for interval graphs, even if they may have $\Omega(n^2)$ edges. Speedups due to succinct representations are ubiquitous in the design of algorithms and data structures.

Formally introduced by Peleg [20], *informative labeling schemes* present a way to formalize implicit representations of graphs. For a given function Π defined on pairs of vertices of a graph from some given family of graphs, an informative labeling scheme has two components: an *encoding algorithm* that associates with each vertex a piece of information (label); and a *decoding algorithm* that computes $\Pi(u, v, G)$, the value of Π applied on vertices u, v of the graph G . The input of the decoding algorithm consists solely of the labels of u and of v , with no other information provided. So, finding an implicit representation of a graph G can be restated as computing an *adjacency labeling scheme* for G , that is, an informative labeling scheme where $\Pi(u, v, G)$ is TRUE if and only if u, v are adjacent in G .

This work is a part of project TOTAL (Michał Pilipczuk) that have received funding from the European Research Council (ERC) under the European Union's Horizon 2020 research and innovation programme (grant agreement No. 677651). It is also partially funded by the French ANR projects ANR-16-CE40-0023 (DESCARTES) and ANR-17-CE40-0015 (DISTANCIA).

¹Throughout this extended abstract, we denote by $\log n$ the binary logarithm of n .



2 Planar Graphs

Planar graphs are perhaps the most studied family of graphs in this area, due to the wide variety of their implicit representations. To mention just a few, planar graphs are contact graphs of circles [19], of 3D boxes [23], of triangles [11], and more recently, of L-shapes [17]. They also have 1-string representations [9]. Each of these representations leads to a labelling scheme where each vertex can be encoded using a label consisting of $O(\log n)$ bits, independent of its degree.

The first explicit bound on the label length, given by Kannan et al. [18], was $4 \lceil \log n \rceil$ bits. The representation in terms of dimension-3 posets due to Schnyder [22] actually implies a $3 \lceil \log n \rceil$ bit labeling, and similar bounds can be derived from polynomial sized universal graphs (cf. related work below). By significantly improving the labeling scheme for bounded treewidth graphs, namely from $O(k \log n)$ [18] to $\log n + O(k \log \log n)$, Gavaille and Labourel [16] showed that partitioning the edges of a planar graph into two bounded treewidth subgraphs, rather than into three forests, leads to a shorter representation: with labels consisting of $2 \log n + O(\log \log n)$ bits. This is the currently best upper bound for planar graphs, see also Table 2 for the best results for sub-families of planar graphs.

Graph families (with n vertices)	Upper bound (label length in bits)	References
maximum degree-2	$\log n + O(1)$	[8, 14, 1]
caterpillars	$\log n + O(1)$	[7]
bounded degree trees	$\log n + O(1)$	[10]
bounded depth trees	$\log n + O(1)$	[15]
trees	$\log n + O(1)$	[4]
bounded degree outerplanar	$\log n + O(1)$	[10, 2]
outerplanar	$\log n + o(\log n)$	[16]
bounded treewidth planar	$\log n + o(\log n)$	[16]
maximum degree-4 planar	$\frac{3}{2} \log n + o(\log n)$	[2]
bounded degree planar	$2 \log n + O(1)$	[10]
planar	$2 \log n + o(\log n)$	[16]
diameter- d planar	$\log n + \log d + o(\log n)$	[new]
planar	$\frac{4}{3} \log n + o(\log n)$	[new]

Table 1: State-of-the-art for adjacency labeling schemes on planar graphs and some sub-families. All the second-order terms quoted above as $o(\log n)$ are in $O(\log \log n)$. The bounds from references [10, 14, 8] come from induced-universal graphs, whereas all the others come from labeling schemes. The only known lower bound for planar graphs is $\log n + \Omega(1)$.

3 Our Contribution

As shown in Table 2, in this work we present a new labeling scheme for planar graphs that uses labels of length bounded² by $\frac{4}{3} \log n$. Note that this not only improves the previously best known bound of $2 \log n$ for general planar graphs [16], but even the refined bound of $\frac{3}{2} \log n$ for the case of planar graphs of maximum degree 4 [2]. Our contribution is actually three-fold.

²For brevity, in this informal exposition we ignore terms of lower order $o(\log n)$.

First, we design a labeling scheme with labels of length $\log n + \log d$ if the graph has diameter at most d . This parametrized bound is never worse than the currently best known bound of $2 \log n$, because we always have $d < n$. Our scheme is based on a recent decomposition theorem, which states that the vertices of a planar graph can be partitioned into geodesics (shortest paths) so that contracting every geodesic to a single vertex turns the graph into a graph of constant treewidth. This was first proved by Pilipczuk and Siebertz in [21], and then refined by Dujmović et al. [13] as follows: the geodesics in the partition can be selected from any fixed BFS forest of the graph. This statement was used in [13] to prove that planar graphs have bounded queue number and in [12] to prove that they have bounded nonrepetitive chromatic number, which resolved two long-standing open questions in graph theory. Thus, in this work we provide another application of the result of Dujmović et al.: a construction of shorter labeling schemes for planar graphs.

The second contribution is the main one: a labeling scheme for planar graphs that uses labels of length $\frac{4}{3} \log n$. To achieve this, we combine the scheme for planar graphs of low diameter with the layering technique. Essentially, we compute a decomposition of the graph into strips of depth bounded by some parameter $d \in \mathbb{N}$. Strips are separated by borders whose union is a graph on $O(n/d)$ vertices and of constant treewidth. Using the results of [16], for this border graph we can compute a labeling with labels of length $\log(n/d)$. On the other hand, the low-diameter result provides a scheme for the strips with labels of length at most $\log n + \log d$. At this point, superposing these two schemes gives no improvement, because vertices appearing at the borders of strips have to inherit labels from both labelings: $\log n + \log d$ from the labeling of the strips and $\log n/d$ from the labeling of the border, which sums up to $2 \log n$. However, by revisiting the scheme for graphs of bounded treewidth we are able to show that for vertices at the borders of strips, the labeling for strips can use much shorter labels: only of length $\log(n/d)$ instead of $\log n + \log d$. Hence, the combined labels of border vertices are of length at most $2 \log(n/d)$, implying that every vertex receives a label of length bounded by

$$\max \{ \log n + \log d, 2 \log(n/d) \}.$$

This expression is minimized for $d = n^{1/3}$ and then evaluates to $\frac{4}{3} \log n$, the desired bound.

The third contribution is a generalization of the previous technique to graphs of bounded Euler genus. Namely, for every fixed $g \in \mathbb{N}$, we construct a labelling scheme for graphs of Euler genus at most g that uses labels of length at most $\frac{4}{3} \log n$.

In all our labeling schemes, we can compute the labeling of all the vertices of the graph in polynomial time, while the adjacency can be determined from the labels in constant time.

4 Connections with Universal Graphs

It has been observed in [18] that the design of labeling schemes with short labels is tightly connected with the construction of small induced-universal graphs. Recall that a graph \mathcal{U} is induced-universal for a given set of graphs \mathcal{S} if every graph $G \in \mathcal{S}$ is isomorphic to some induced subgraph of \mathcal{U} . Then graphs from \mathcal{S} admit a labeling scheme with k -bit labels if and only if \mathcal{S} has an induced-universal graph \mathcal{U} with at most 2^k vertices, see [18]. Thus, our new labeling scheme provides an explicit construction of an induced-universal graph for n -vertex planar graphs that has $n^{4/3+o(1)}$ vertices, improving upon the previously best known bound of $n^{2+o(1)}$, derived from [16].

Therefore, we proved that the minimum possible number of vertices of an induced-universal graph for n -vertex planar graphs lies between $\Omega(n)$ and $n^{4/3+o(1)}$. The search for optimum bounds on the sizes of induced-universal graphs is a well-studied topic in graph theory, see for example the recent developments for general n -vertex graphs [3, 5] and for n -vertex trees [4]. We refer readers interested in this topic to the recent survey of Alstrup et al. [6].

References

- [1] M. ABRAHANSEN, S. ALSTRUP, M. BÆK TEJS KNUDSEN, AND M. STÖCKEL, *Near-optimal induced universal graphs for cycles and paths*, TR 1607.04911v2 [cs.DS], arXiv, July 2016.
- [2] D. ADJIASHVILI AND N. ROTBART, *Labeling schemes for bounded degree graphs*, in 41st International Colloquium on Automata, Languages and Programming (ICALP), vol. 8573 of Lecture Notes in Computer Science (ARCoSS), Springer, July 2014, pp. 375–386.
- [3] N. ALON, *Asymptotically optimal induced universal graphs*, Geometric and Functional Analysis, 27 (2017), pp. 1–32.
- [4] S. ALSTRUP, S. DAHLGAARD, AND M. BÆK TEJS KNUDSEN, *Optimal induced universal graphs and adjacency labeling for trees*, Journal of the ACM, 64 (2017), p. Article No. 27.
- [5] S. ALSTRUP, H. KAPLAN, M. THORUP, AND U. ZWICK, *Adjacency labeling schemes and induced-universal graphs*, in 47th Annual ACM Symp. on Theory of Computing (STOC), ACM Press, June 2015, pp. 625–634.
- [6] ———, *Adjacency labeling schemes and induced-universal graphs*, SIAM Journal on Discrete Mathematics, 33 (2019), pp. 116–137.
- [7] N. BONICHON, C. GAVOILLE, AND A. LABOUREL, *Short labels by traversal and jumping*, in 13th International Colloquium on Structural Information & Communication Complexity (SIROCCO), vol. 4056 of Lecture Notes in Computer Science, Springer, July 2006, pp. 143–156.
- [8] S. BUTLER, *Induced-universal graphs for graphs with bounded maximum degree*, Graphs and Combinatorics, 25 (2009), pp. 461–468.
- [9] J. CHALOPIN, D. GONÇALVES, AND P. OCHEM, *Planar graphs have 1-string representations*, Discrete & Computational Geometry, 43 (2010), pp. 626–647.
- [10] F. R. K. CHUNG, *Universal graphs and induced-universal graphs*, Journal of Graph Theory, 14 (1990), pp. 443–454.
- [11] H. DE FRAYSSEIX, P. OSSONA DE MENDEZ, AND P. ROSENSTIEHL, *On triangle contact graphs*, Combinatorics, Probability & Computing, 3 (1994), pp. 233–246.
- [12] V. DUJMOVIĆ, L. ESPERET, G. JORET, B. WALCZAK, AND D. R. WOOD, *Planar graphs have bounded nonrepetitive chromatic number*, TR 1904.05269v1 [math.CO], arXiv, 2019.
- [13] V. DUJMOVIĆ, G. JORET, P. MICEK, P. MORIN, T. UECKERDT, AND D. R. WOOD, *Planar graphs have bounded queue-number*, TR 1904.04791v2 [cs.DM], arXiv, May 2019.
- [14] L. ESPERET, A. LABOUREL, AND P. OCHEM, *On induced-universal graphs for the class of bounded-degree graphs*, Information Processing Letters, 108 (2008), pp. 255–260.
- [15] P. FRAIGNIAUD AND A. KORMAN, *Compact ancestry labeling schemes for XML trees*, in 21st Symp. on Discrete Algorithms (SODA), ACM-SIAM, Jan. 2010, pp. 458–466.
- [16] C. GAVOILLE AND A. LABOUREL, *Shorter implicit representation for planar graphs and bounded treewidth graphs*, in 15th Annual European Symp. on Algorithms (ESA), L. Arge and E. Welzl, eds., vol. 4698 of Lecture Notes in Computer Science, Springer, Oct. 2007, pp. 582–593.
- [17] D. GONÇALVES, L. ISENMANN, AND C. PENNARUN, *Planar graphs as L -intersection or L -contact graphs*, in 29th Symp. on Discrete Algorithms (SODA), ACM-SIAM, 2018, pp. 172–184.
- [18] S. KANNAN, M. NAOR, AND S. RUDICH, *Implicit representation of graphs*, in 20th Annual ACM Symp. on Theory of Computing (STOC), ACM Press, May 1988, pp. 334–343.
- [19] P. KOEBE, *Kontaktprobleme der konformen abbildung*, Berichte über die Verhandlungen der Sächsische Akad. der Wissenschaften zu Leipzig, Math.-Phys. Klasse, 88 (1936), pp. 141–164.
- [20] D. PELEG, *Informative labeling schemes for graphs*, in 25th International Symp. on Mathematical Foundations of Computer Science (MFCS), vol. 1893 of Lecture Notes in Computer Science, Springer, Aug. 2000, pp. 579–588 & Theoretical Computer Science, 340 (2005), pp. 577–593.
- [21] M. PILIPCZUK AND S. SIEBERTZ, *Polynomial bounds for centered colorings on proper minor-closed graph classes*, in 30th Symp. on Discrete Algorithms (SODA), Jan. 2019, pp. 1501–1520.
- [22] W. SCHNYDER, *Planar graphs and poset dimension*, Order, 5 (1989), pp. 323–343.
- [23] C. THOMASSEN, *Interval representations of planar graphs*, Journal of Combinatorial Theory, Series B, 40 (1986), pp. 9–20.

Partition-crossing hypergraphs

*Csilla Bujtás*¹, and *Zsolt Tuza*^{2,3}

¹ Faculty of Mathematics and Physics, University of Ljubljana, Slovenia

² Faculty of Information Technology, University of Pannonia, Veszprém, Hungary

³ Alfréd Rényi Institute of Mathematics, Hungarian Academy of Sciences, Hungary

EXTENDED ABSTRACT

Introduction

For a finite set X , we say that a set $H \subseteq X$ crosses a partition $\mathcal{P} = (X_1, \dots, X_k)$ of X if H intersects $\min(|H|, k)$ partition classes. If $|H| \geq k$, this means that H meets all classes X_i , whilst for $|H| \leq k$ the elements of the crossing set H belong to mutually distinct classes. A set system \mathcal{H} crosses \mathcal{P} , if so does some $H \in \mathcal{H}$. The minimum number of r -element subsets, such that every k -partition of an n -element set X is crossed by at least one of them, is denoted by $f(n, k, r)$.

The problem of determining these minimum values for $k = r$ was raised and studied by several authors independently in different contexts, first by Sterboul in 1973 [8] (cochromatic number), also discussed by Berge [3], Arocha et al. [1] (heterochromatic number), and Voloshin [10, 11] (upper chromatic number). In 2009, the present authors determined asymptotically tight estimates on $f(n, k, k)$ for every fixed k as $n \rightarrow \infty$ [4].

Here we consider the more general problem for two parameters k and r and establish lower and upper bounds for $f(n, k, r)$. For various combinations of the three values n, k, r we obtain asymptotically tight estimates, and also point out close connections of the function $f(n, k, r)$ to Turán-type extremal problems on graphs and hypergraphs, or to balanced incomplete block designs.

We shall use the term *hypergraph* for the pair (X, \mathcal{H}) — where X is the set of *vertices* and \mathcal{H} is the set of *edges* — and also for the set system \mathcal{H} itself, when X is understood. The number of vertices is called the *order* of \mathcal{H} , and will usually be denoted by n .

Earlier results

One can observe that a hypergraph crosses all 2-partitions of its vertex set if and only if it is connected. For this reason we obtain that

$$f(n, 2, r) = \left\lceil \frac{n-1}{r-1} \right\rceil$$

because this is the minimum number of edges in a connected r -uniform hypergraph of order n .

Let us observe further that the case of $r = 2$ simply means graphs with at most $k - 1$ connected components, therefore

$$f(n, k, 2) = n - k + 1.$$

This strong relationship with connected components, however, does not extend to $r > 2$.

It seems that for $k \geq 3$ and $r \geq 3$ only the ‘diagonal case’ $k = r$ of $f(n, k, r)$ was studied earlier.

- $f(n, k, k) \geq \frac{2}{n-k+2} \binom{n}{k}$, for every $n \geq k \geq 3$ ([9]; later proved independently in [1], and also in [7]).
- $f(n, 3, 3) = \lceil \frac{n(n-2)}{3} \rceil$, for every $n \geq 3$ ([6]; proved independently in a series of papers whose completing item is [2]).

- $f(n, n-2, n-2) = \binom{n}{2} - \text{ex}(n, \{C_3, C_4\})$ holds for every $n \geq 4$, where the last term is the Turán number for graphs of girth 5 ([9]).

Although the exact value of $f(n, k, k)$ is not known for any $k > 3$, its asymptotic behavior has been determined for quite a wide range of k .

Theorem 1 (Bujtás, Tuza, '09 [4]) *Assume $n > k > 2$.*

- (i) $f(n, k, k) \leq \frac{2}{n-1} \binom{n-1}{k} + \frac{n-1}{k-1} \left(\binom{n-2}{k-2} - \binom{n-k-1}{k-2} \right)$ for all n and k .
- (ii) $f(n, k, k) = (1 + o(1)) \frac{2}{k} \binom{n-2}{k-1}$ for all $k = o(n^{1/3})$ as $n \rightarrow \infty$.

In the remaining part of the extended abstract we present our main new results. These theorems and their proofs can be found in the paper [5].

Monotonicity

Theorem 2 *For every three integers r, k, k' , if either*

- (i) $2 \leq r \leq k \leq k' \leq n$, or
- (ii) $2 \leq k' \leq k \leq r \leq n$

holds, and an r -uniform hypergraph \mathcal{H} crosses all k -partitions of the vertex set, then \mathcal{H} crosses all k' -partitions, as well. As a consequence, for every four integers n, k, k', r satisfying (i) or (ii) we have

$$f(n, k, r) \geq f(n, k', r).$$

The following corollaries show the central role of the ‘symmetric’ case $k = r$:

Corollary 3 *If an r -uniform hypergraph \mathcal{H} crosses all r -partitions of the vertex set X , then \mathcal{H} crosses all partitions of X .*

Numerically, we have obtained that the function $f_{n,r}(x) = f(n, x, r)$ (where x is an integer in the range $2 \leq x \leq n$) has its maximum value when $x = r$; and the situation is similar if n and k are fixed and r is variable; that is, the function $f_{n,k}(x) = f(n, k, x)$ attains its maximum at $x = k$.

Corollary 4 *For every three integers $n \geq k, r \geq 2$,*

$$f(n, k, r) \leq f(n, k, k).$$

Corollary 5 *For every three integers $n \geq k, r \geq 2$,*

$$f(n, k, r) \leq f(n, r, r).$$

Lower bound for non-uniform systems

For hypergraphs without very small edges, we prove the following general inequality.

Theorem 6 *Let $k \geq 2$ be an integer, and let (X, \mathcal{H}) be a hypergraph of order n , which contains no edge $H \in \mathcal{H}$ of cardinality smaller than k . If \mathcal{H} crosses all k -partitions of X , then*

$$\sum_{H \in \mathcal{H}} \binom{|H|}{k} \frac{1}{|H| - k + 2} \geq \binom{n}{k} \frac{1}{n - k + 2}.$$

Sharp example. Let $n = |X| = 2m$ be even. Let the edge set of \mathcal{H} consist of one m -subset H of X together with m mutually disjoint 2-element sets, each of which has precisely one vertex in H and one in $X \setminus H$. This hypergraph crosses all partitions of X . Indeed, if none of the m selected 2-sets crosses a partition \mathcal{P} , then each class of \mathcal{P} meets H . For this \mathcal{H} , both sides of the inequality in Theorem 6 equal $\frac{n-1}{2}$ for $k = 2$. (We necessarily have $k = 2$, due to the conditions in the theorem.)

Estimates for $k \leq r$

For this case we may conclude a lower bound immediately from Theorem 6.

Corollary 7 *For every three integers $n \geq r \geq k \geq 2$ the inequality*

$$f(n, k, r) \geq \frac{\binom{n}{k}}{\binom{r}{k}} \cdot \frac{r - k + 2}{n - k + 2}$$

holds.

On the other hand, we proved the following general asymptotic upper bound.

Theorem 8 *For every two fixed integers $r \geq k \geq 2$ the inequality*

$$f(n, k, r) \leq \frac{\binom{n}{k}}{\binom{r}{k}} \cdot \frac{r}{n} + o(n^{k-1})$$

holds as $n \rightarrow \infty$.

Estimates for $k \geq r$

Theorem 9 *For every three integers $n \geq k \geq r \geq 2$ the inequality*

$$f(n, k, r) \geq \frac{\binom{n}{r-1}}{\binom{k-2}{r-2}} \cdot \frac{n - k + 2}{r(n - r + 2)}$$

holds.

For k and r fixed, the lower bound gives the right order $O(n^{r-1})$, as shown by the following theorem which is proved by a construction.

Theorem 10 *Let $k \geq 3$, and assume that $k - 2$ is divisible by $r - 2$. If $n \rightarrow \infty$, then*

$$f(n, k, r) \leq \frac{2(r-2)^{r-2}}{r(k-2)^{r-2}} \binom{n}{r-1} + o(n^{r-1}).$$

References

- [1] J. L. Arocha, J. Bracho, V. Neumann-Lara. On the minimum size of tight hypergraphs. **J. Graph Theory**, 16:319–326, 1992.
- [2] J. L. Arocha, J. Tey. The size of minimum 3-trees. **J. Graph Theory**, 54:103–114, 2007.
- [3] C. Berge. Hypergraphs. North-Holland, 1989.
- [4] Cs. Bujtás, Zs. Tuza. Smallest set-transversals of k -partitions. **Graphs Combin.**, 25:807–816, 2009.
- [5] Cs. Bujtás, Zs. Tuza. Partition-crossing hypergraphs. **Acta Cybernetica**, 23:815–828, 2018.
- [6] K. Diao, G. Liu, D. Rautenbach, P. Zhao. A note on the least number of edges of 3-uniform hypergraphs with upper chromatic number 2. **Discrete Math.**, 306:670–672, 2006.
- [7] K. Diao, P. Zhao, H. Zhou. About the upper chromatic number of a C -hypergraph. **Discrete Math.**, 220:67–73, 2000.
- [8] F. Sterboul. A new combinatorial parameter. **Infinite and Finite Sets** (A. Hajnal et al., eds.), Colloq. Math. Soc. J. Bolyai, North-Holland/American Elsevier, 10:1387–1404, 1975.
- [9] F. Sterboul. Un problème extrémal pour les graphes et les hypergraphes. **Discrete Math.**, 11:71–78, 1975.
- [10] V. Voloshin. On the upper chromatic number of a hypergraph. **Australasian J. Combin.** 11:25–45, 1995.
- [11] V. Voloshin. Coloring Mixed Hypergraphs: Theory, Algorithms and Applications. Fields Institute Monographs, 17, AMS, 2002.

A note on the inflating enclosing ball problem

*Nikola K. Blanchard*¹ and *Siargey Kachanovich*²

¹ IRIF, Université Paris Diderot, France & Loria, Université de Lorraine

² Université Côte d'Azur, INRIA Sophia-Antipolis, France

EXTENDED ABSTRACT

1 Introduction

Our goal in this paper is, given a connected set of balls, to select and inflate one ball to cover the whole set with the minimal radius. More formally, we are given an abstract metric space and a path-connected set of balls with given centres c_1, c_2, \dots, c_n and radii r_1, r_2, \dots, r_n . We want to choose one of the centres and create a ball of radius R around it to cover the whole set of balls with minimal R . By using arguments from graph theory, we show that $R \leq r_a + \sum_j r_j$, where r_a is the mean of the two biggest radii among the r_i . This bound is tight. Finally, we show that in the usual complexity models, computing this centre requires $\Theta(n^2)$ operations.

This problem is closely related to the smallest enclosing ball problem, which has been studied since the early 1980s [Meg83, Wel91, MNV13]. The main difference is that, instead of computing the smallest enclosing ball without constraints on the centre, our centre is imposed from a small set, and we are concerned with precise bounds on the radius. Our motivation comes from facility location [GK99, CP04, Vyg05] and dynamic clustering problems [EMS14, ANS15], where fractional solutions to the linear programs generally come in the form of such structures. Being able to replace a connected set of balls by a single optimal ball in such problems could be a step towards solutions that have better approximation ratios and are easier to analyse, especially in the dynamic metric setting where some bounds are still far from being tight [BS17].

2 Upper and lower bounds

Definitions

We work in a general metric space E endowed with a distance $d(.,.)$ and the natural topology generated by open balls. Paths on E are well-defined as continuous functions $[0, 1] \rightarrow E$.

We consider a set of n points $c_1, c_2 \dots c_n$ in the metric space E , and to each point c_i associate a closed ball B_i of radius r_i (corresponding to all the points in E that are at distance at most r_i from c_i). The subspace corresponding to the union of all the balls will be written as S . We have one constraint on the set of balls: the union S is assumed to be *path-connected*, meaning that there is a path from x to y through S , for any $x, y \in S$.

Problem

We seek to cover S by increasing the radius of a single ball, and have two questions. Which center c_i should we choose, and how can we minimise the ratio of the new radius R compared to the sum of the previous radii? That is, how do we minimise

$$\frac{R}{\sum_j r_j}.$$

The immediate answer is to find the ball closest to the “center” of S and open it with a sufficient radius, but that center might not be easy to manipulate in some abstract metric spaces and does not immediately give the best bound. Before proving the tight, bound we need an elementary lemma.

Lemma 1. *If a shortest path P between two arbitrary points $x, y \in S$ through S is of length d , then the sum of radii $\sum_j r_j$ is at least $d/2$.*

Proof. Without loss of generality, let B_1, \dots, B_k be the sequence of balls that the path P follows. Note that by the triangle inequality, the path P passes through each ball once — otherwise there exists a shorter path between x and y than P , which contradicts P being the shortest. Write e_1, \dots, e_k to be the “entry” points on the path P into the balls B_1, \dots, B_k respectively. We will define by convention $e_1 = x$ and $e_{k+1} = y$. We have $d(e_1, e_2) + d(e_2, e_3) + \dots + d(e_k, e_{k+1}) = d$. By the triangle inequality with the centres c_1, c_2, \dots, c_k , we finally get:

$$d = \sum_{i=1}^k d(e_i, e_{i+1}) \leq \sum_{i=1}^k (d(e_i, c_i) + d(c_i, e_{i+1})) \leq \sum_{i=1}^k 2r_i \leq 2 \sum_{i=1}^n r_i.$$

□

From Lemma 1 it follows that we can easily have $\frac{R}{\sum_j r_j} \leq 2$ by opening any facility with a big enough radius to cover everyone. Suppose that we take a centre c_i and a point x farthest from i , opening i with radius $d(i, x)$ is enough to cover S (because a point not inside that new ball would have to be at distance higher than $d(i, x)$). But the cost of the initial solution was at least $d(i, x)/2$, hence the result.

The previous result can be extended to arbitrary paths as long as their total length inside each ball is at most $2r_i$. If there is a path of length d satisfying such a condition, $\sum_j r_j \geq d/2$.

We also need a theorem from graph theory:

Theorem 2 ([WC04]). *For any tree graph T , we have:*

$$2 \times \text{radius} - \max_{i,j} (d(c_i, c_j)) \leq \text{diameter}.$$

Our goal is now to prove the following:

Theorem 3. *We can always cover S by a ball with radius $R \leq r_a + \sum_j r_j$, where r_a is the mean of the two biggest radii among the r_i .*

Proof. Let us consider a weighted complete graph K_n with c_1, \dots, c_n as nodes, where the weight of an edge (c_i, c_j) is equal to $d(c_i, c_j)$. Let T be a minimum spanning tree of the graph G . We expand T to a second tree T' in the following way. For each node c_i of T , we add a leaf l_{ij} for each c_j with $j \neq i$ (thus making the number of nodes in T' equal to n^2). The weight of an edge (l_{ij}, c_i) is set to be equal to the maximum distance between the centre c_j and a point in B_i .

We observe that, if we define the ball centred at a central node of T' with radius R equal to the radius of T' , then this ball covers S entirely. Let us now take a path corresponding to the diameter of the tree T' . We know that its length d is less than $2 \sum_j r_j$. We also know from Theorem 2 that $d \geq 2 \times R - \max_{i,j} d(c_i, c_j)$. However, $d(c_i, c_j)$ is at most the sum of the two biggest radii among the r_j , which we will denote by $2r_a$. By combining this with Lemma 1, we get that:

$$R \leq \frac{d}{2} + r_a \leq r_a + \sum_j r_j$$

□

Lemma 4. *This bound is tight.*

Proof. Consider two balls of radius r in the Euclidean space that touch in a single point. Any of these two balls has to be inflated with radius $3r$ to cover their union. This proves the lower bound. □

Remark 5. We can consider another situation in the Euclidean space, to show that this bound applies to instances of arbitrary sizes. Suppose that we have an even number $2n$ of identical balls of radius r in a line touching one another and a ball of a high radius r' on each side of the middle of the line. The optimal solution is then to inflate one the two big balls with sufficient radius to cover everyone other ball. The radius of the inflated ball in this case is $2n \times r + 3r_a$, while the sum of radii is $2n \times r + 2r_a$.

Remark 6. If we don't look at the values of the radii but only consider a multiplicative bound, this means that we can get examples with $\frac{3}{2} \leq \frac{R}{\sum_j r_j}$ (as in the first previous example), and the theorem becomes $\frac{R}{\sum_j r_j} \leq \frac{3}{2}$.

3 Algorithmic considerations

Using the same notations as before, we now look at the following algorithmic question: in how many operations can we find a centre $c^* \in \{c_1, \dots, c_n\}$ such that we can cover all balls B_1, \dots, B_n by a ball centred at c^* with minimal possible radius R . The answer to this question depends on the choice of the model of how the input data is accessed. We will now investigate multiple models and give the lower bounds on the worst-case complexities for each of them.

Different input methods. We consider three models. The first and most general is: given any two centres c_1 and c_2 , we have access to an oracle that outputs the distance between c_1 and c_2 in $O(1)$ time. This corresponds to a matrix representation of the complete distance graph.

An alternative is to have an adjacency list, where for each ball we can access in $O(1)$ time to its radius as well as to the list of all centres within the ball – potentially sorted by distance to the ball's centre.

General algorithm. We will now describe a simple algorithm that finds c^* . We compute for each centre c_i , the radius of the smallest ball centred at c_i that covers S . We will leave for now the complexity of finding this radius as a parameter k . To find c^* , we pick the centre with the minimal such radius. As we have n different centres, the complexity of the algorithm is thus $O(nk)$.

If we have access to the distance between c_i and c_j in $O(1)$ operations – or access to the list of distances between c_i and all c_j – we can check each center in $O(n)$, leading to an $O(n^2)$ algorithm. As shown in the following lemma, we cannot do better than this in the general case.

Lemma 7. *With the matrix representation, $\Omega(n^2)$ queries can be needed, making the previous algorithm asymptotically optimal.*

Proof. We will use an adversary argument, with a game for two players on a complete graph K_n , where the n nodes correspond to the centres c_1, \dots, c_n . All edge weights in the graph K_n can be either 1 or $1 + \varepsilon$ for some fixed $\varepsilon \in (0, 1)$. Note that any assignment of the weights on the edges in the graph K_n satisfies the triangle inequality, hence the weighted graph K_n defines a metric space.

The first player (the user) chooses an edge in the graph and the second player (the adversary) chooses the weight of this edge from 1 and $1 + \varepsilon$. The goal of the user is to efficiently decide whether there exists a node in the graph K_n such that all its incident edges have weight 1, with the adversary trying to make the user lose as much time as possible. We will now show that the adversary has a strategy to make the user pick $\Omega(n^2)$ edges in K_n to decide.

Let e be an edge picked by the first player with two endpoints c_i and c_j . If e is not the last picked edge for either c_i or c_j , then the adversary assigns to the edge e the weight 1. Otherwise, the adversary assigns to e the weight $1 + \varepsilon$, unless c_i or c_j is the last node with no

distance equal to $1 + \varepsilon$. In this case, the adversary arbitrarily sets the distance to be either 1 or $1 + \varepsilon$.

Recall that the user needs to check for each node if there is an incident edge with weight $1 + \varepsilon$. When an edge with weight $1 + \varepsilon$ is detected, this check is complete for the two endpoints of the edge. Therefore, at least $\lceil n/2 \rceil$ edges with weight $1 + \varepsilon$ need to be queried. Moreover, by construction, for each such edge, at least $n - 2$ edges of weight 1 were queried previously. We counted each edge of weight 1 at most twice, leaving us with at least $n(n - 2)/4$ edges of weight 1 required to query. In total, the user is therefore required to pick $O(n^2)$ edges. \square

Remark 8. Although it requires an involved and technical proof, it can be shown that this instance can be embedded in \mathbb{R}^n . Any weight assignment to the edges of K_n satisfies the triangle inequality, corresponding to a sub-constrained problem that can be satisfied in \mathbb{R}^n .

4 Discussion

This paper leaves open multiple algorithmic questions. First, can better algorithms be found in the general case, using the number of edges as a parameter instead of the number of centres? For example, it could be possible to get $\tilde{O}(m)$ complexity by extending the constructive proof of Theorem 3, building a spanning tree and finding its centre in $O(m \log^* m)$. However, this requires finding a way to avoid the quadratic increase in size due to the construction of T' .

A different possible direction is to look not for optimal solutions but for satisficing ones, where any center with $R \leq r_a + \sum_j r_j$ is considered a valid solution. In such a case, one could get rid of dense parts of the graph by only looking at the top three furthest neighbours and absorbing them into the ball currently considered. Most importantly, could the methods shown in this paper improve the bounds or give access to simpler proofs of the results for clustering and facility location problems, such as the ones in [CP04]?

Acknowledgements. This work was supported partly by the french PIA project “Lorraine Université d’Excellence”, reference ANR-15-IDEX-04-LUE.

References

- [ANS15] Hyung-Chan An, Ashkan Norouzi-Fard, and Ola Svensson. Dynamic facility location via exponential clocks. In *SODA*, pages 708–721, 2015.
- [BS17] Nikola K. Blanchard and Nicolas Schabanel. Dynamic Sum-Radii Clustering. In Sheung-Hung Poon, Md. Saidur Rahman, and Hsu-Chun Yen, editors, *WALCOM: Algorithms and Computation: 11th International Conference and Workshops – WALCOM*, pages 30–41. Springer International Publishing, 2017.
- [CP04] Moses Charikar and Rina Panigrahy. Clustering to minimize the sum of cluster diameters. *Journal of Computer and System Sciences*, 68(2):417–441, 2004.
- [EMS14] David Eisenstat, Claire Mathieu, and Nicolas Schabanel. Facility location in evolving metrics. In *ICALP*, pages 459–470, 2014.
- [GK99] Sudipto Guha and Samir Khuller. Greedy strikes back: Improved facility location algorithms. *Journal of Algorithms*, pages 228–248, 1999.
- [Meg83] Nimrod Megiddo. Linear-time algorithms for linear programming in \mathbb{R}^3 and related problems. *SIAM journal on computing*, 12(4):759–776, 1983.
- [MNV13] Boris Mordukhovich, Nguyen Mau Nam, and Cristina Villalobos. The smallest enclosing ball problem and the smallest intersecting ball problem: existence and uniqueness of solutions. *Optimization Letters*, 7(5):839–853, 2013.
- [Vyg05] Jens Vygen. Approximation algorithms for facility location problems. Lecture Notes, 2005.
- [WC04] Bang Ye Wu and Kun-Mao Chao. *Eccentricities, diameters, and radii*, chapter 7, pages 165–173. CRC Press, 2004.
- [Wel91] Emo Welzl. Smallest enclosing disks (balls and ellipsoids). In Hermann Maurer, editor, *New Results and New Trends in Computer Science*, pages 359–370, Berlin, Heidelberg, 1991. Springer Berlin Heidelberg.

Counting authorised paths in constrained control-flow graphs

Nikola K. Blanchard¹ and Siargey Kachanovich²

¹ IRIF, Université Paris Diderot, France & Loria, Université de Lorraine

² Université Côte d'Azur, INRIA Sophia-Antipolis, France

EXTENDED ABSTRACT

1 Introduction and problem definition

Our goal in this extended abstract is to investigate a model of computation inspired by control-flow graphs (CFG) [All70], automata and arithmetic circuits. The objective is to extend the definition of the first to include computing on nodes and edges.

We are given a directed graph and a set of integer variables, with every edge in the graph being augmented in two ways. First, a set of constraints on the variables determines whether the edge is *authorised*. Second, to each edge is associated a function that affects the values of the variables. In this complex model, we seek to estimate the length and number of distinct paths. We restrict ourselves to the two cases in which this has meaning: when the underlying graph is a DAG, or when we have a promise that paths of infinite length do not exist in the given graph. This has varied applications, from bounding the number of execution paths in various computing models (both deterministic and non-deterministic), to counting the number of distinct stories in interactive fictions. This problem is easy in the case of trees — checking whether each node is reachable can be done in linear time by a BFS — or in the case of directed acyclic graphs, where we can use dynamic programming. However, adding constraints on the values of variables can make it untractable, even with small graphs.

We focus on a simplified model — *constrained control-flow graphs* (CCFG) — defined by:

- A directed graph G with n nodes and $m \leq n^2$ directed edges (loops are authorised).
- A vector of k variables $V = (v_1, \dots, v_k)$, all initialised at 0.
- A function f_e for each edge e , that associates a boolean to V , taking the value TRUE only if the edge is authorised for the value of V (see below).
- A vector V^e for each edge e , with the rule that, when going through e on a path, we assign $V := V + V^e$. This vector can have negative coordinates.
- An integer B , such that $\forall(V, e), \left(f_e(V) \implies \forall i, (0 \leq v_i + V_i^e \leq B) \right)$.

In such a model, we seek to count or estimate the maximum number Π of *authorised paths*, that is, paths such that each edge taken follows the constraints of f_e . We are also interested in the lengths of such paths, as they have a direct impact on the number of paths. The maximal length of any authorised path will be denoted by Λ .

Crucially, Π and Λ only exist if there is no path of infinite length. An equivalent property is that there exists no cycle that leaves all variables unchanged.

2 Upper bounds

We start by giving upper bounds on Λ . The first is useful when there are few variables, whereas the second addresses the case when the variables greatly outnumber the nodes.

Lemma 1. *All authorised paths have length bounded by $n \times (B + 1)^k$.*

Proof. As each variable can take $B + 1$ different values, there are $n \times (B + 1)^k$ pairs (a, V) where a is a node. If a path has length $> n \times (B + 1)^k$, one such pair must be present twice, and there is a cycle that leaves the variables unchanged. \square

We can get an alternative upper bound on Λ in the case of $m < k$.

Lemma 2. *All authorised paths have length bounded by $n \times 2^m k^{m/2} \binom{k}{m} B^m$.*

Proof. We will prove the lemma geometrically by a volume argument. All possible values of the vector V are integer grid points inside a k -dimensional cube C of side B . The values V_e for all edges e span a linear space L of dimension at most m . Our goal is to estimate the number of integer grid points N that lie on the intersection $C \cap L$. Once we have this number, we can substitute the factor B^k in Lemma 1 to find a bound on the length of a path.

For each of the N points on $C \cap L$, we construct a ball of radius $1/2$. Because these points have integer coordinates, the constructed balls have disjoint interiors. All these balls lie in a tubular neighbourhood (thickening) S of $C \cap L$ of radius $1/2$. With $\text{vol}(B_k)$ denoting the volume of a k -dimensional unit ball, we obtain: $N \times \text{vol}(B_k) (\frac{1}{2})^k \leq \text{vol}(S)$. The volume of S is given by Weyl's tube formula [Wey39]: $\text{vol}(S) \in O(\text{vol}(C \cap L) \text{vol}(B_{k-m}) (1/2)^{k-m})$. By combining the two formulae, we get: $N \in O\left(2^m \text{vol}(C \cap L) \frac{\text{vol}(B_{k-m})}{\text{vol}(B_k)}\right)$.

Moreover, $\text{vol}(C \cap L)$ is upper-bounded by the volume of an m -dimensional ball of radius the diagonal of the cube C . This volume is $\text{vol}(B_m) (\sqrt{k}B)^m$. The volume of a k -dimensional unit ball is given by [OLBC10]: $\text{vol}(B_k) \sim \left(\frac{2\pi e}{k}\right)^{k/2}$. We therefore have:

$$N \in O\left(2^m k^{m/2} B^m \frac{\text{vol}(B_m) \text{vol}(B_{k-m})}{\text{vol}(B_k)}\right) \subseteq O\left(2^m k^{m/2} B^m \binom{k}{m}\right).$$

□

We can derive an easy bound on Π from Lemma 2.

Corollary 3. *We have:*

$$\Pi \in n^{O(2^m k^{m/2} \binom{k}{m} B^m)}.$$

Proof. The number of ways to compose a path of length Λ from n nodes is n^Λ . We substitute Λ by the upper bound from Lemma 2. □

Remark 4. For some types of graphs, the upper bound on Π is much smaller. For example, the number of paths in a DAG with no variables is upper-bounded by $2^{n-1} - 1$. This bound comes from the complete graph on n nodes oriented in a non-cyclic manner.

3 Lower bounds

We now give constructive lower bounds of the maximum Λ and Π for fixed k or n , in two cases corresponding to Lemmas 1 and 2. Before this, we start by an introductory example on multigraphs.

Multigraph example. If we allow multigraphs, we have a matching bound for Lemma 1. Consider a single node with k loop edges e_1, \dots, e_k . To each edge e_i we assign a vector $V^i = (-B, \dots, -B, 1, 0, \dots, 0)$, with 1 at the i -th place. Each path corresponds to the iterative incrementation of a counter in base $B + 1$, from 0 to $(B + 1)^k - 1$. We can also add a path of length $n - 1$ that ends in node n without changing the variables. From node n , all the loops V^i are replaced by edges towards the first node. This gives: $\Lambda = n \times (B + 1)^k$.

Small k case. If we get back to simple directed graphs — without parallel edges — we have a first lower bound on path length in the case $k < n$. We consider a graph $G_{n,k}$ derived from the previous one, where instead of the edge with vector V^i going from the n -th to the first node, it goes from the n -th to the i -th node. $G_{n,k}$ is then composed of a path on n nodes that does not affect the variables, and k edges from node n to the first k nodes of the path.

As before, the vector V evolves as an incremental integer counter with digits in base $B + 1$ until it reaches the value (B, \dots, B) , returns to the last vertex, and stops as no edge is authorised. To increment the digit at a position i , the path follows the edge from n to i and then returns to n by passing through $i + 1, \dots, n - 1$. We now compute the total length of this path. The number of times the path passes through the edge from n to i is $B(B + 1)^{k-i}$. Afterwards, the path returns to n by following $n - i$ edges. The length of the path is therefore:

$$\sum_{i=1}^k B(B+1)^{k-i}(n-i+1) = \frac{n(B+1)^{k+1} - (n+1)(B+1)^k - (n-k)B+1}{B} \in \Theta(n(B+1)^k).$$

Small n case. When $n^2 < k$, we consider a second kind of graph. This graph consists of a complete graph K_{n-1} on $n - 1$ nodes — including loops, hence with $(n - 1)^2$ edges — and a distinguished node n connected to all other nodes in both ways. Each edge within the complete subgraph K_{n-1} has an associated unique vector of type $(-B, \dots, -B, 1, 0, \dots, 0)$. The edges from n to other nodes are associated to the same vector $(1, 0, \dots, 0)$, while the edges to the node n are associated to the zero vector.

As was the case in the previous graph, the longest authorised path simulates an incremental integer counter on the vector V . This path starts at the node n . To increment the units digit, the path follows any edge from n to a node in K_{n-1} . If the next incrementation is in the digits of some position $i > 1$, then the chosen node is such that there is an outgoing edge associated to a vector $(-B, \dots, -B, 1, 0, \dots, 0)$ with 1 at the i -th coordinate. In this case, the path follows this edge and returns to n . Otherwise, the path simply returns to n . The length of this path is therefore:

$$\Lambda = 2B^{(n-1)^2} + B^{(n-1)^2-1} = (2B + 1)B^{(n-1)^2-1}.$$

We can also count the number of paths in this graph. For each incrementation of the units digit, the path can pass through any of the nodes in the complete subgraph K_{n-1} before returning to n . We obtain the value of Π :

$$\Pi = (n - 1)^{(B-1)B^{(n-1)^2-1}}.$$

4 Using Markov chains to bound Π on given graphs

Algorithmically, finding the number of paths or the length of the greatest path in an arbitrary CCFG is a complex computational problem. The simplest way is to run a breadth-first search and count the number of endpoints, but this has a time complexity at least linear in Π . There are many potential practical improvements, such as analysis of DAG components and discarding redundant variables, but this does not help in the general case.

However, there is a way to give lower bounds on arbitrary graphs in practice. Intuitively, we create a Markov chain over the graph, which induces a probability distribution on all authorised paths, and use an estimator from a generalisation of the birthday problem [Mas92]. This allows us to get a time complexity in at most $\sqrt{\Pi}$ if the Markov chain has optimal values.

More formally, we give to each edge e a weight w_e , and we follow paths by taking a random edge with a distribution that depends on the weights of the authorised edges. Each time we stop (either because we reached a point with no outgoing edge or because the probability of outgoing edges was less than 1), we save that path. We keep drawing paths at random until we get one that we have saved previously. We output the square of the number of paths seen, which serves as an estimator for the total number of paths. For example, in the special case where all Π paths have an equal probability, we know that the expected number of trials T

before a collision follows [CP⁺00]: $\frac{-2}{5} < T - \sqrt{\pi\Pi}/2 < \frac{8}{5}$. As such, computing T^2 can give an estimate for Π . However, as the distribution is generally not uniform, T^2 is actually a lower bound for Π as the probability of getting a collision is a convex function of the p_i .

Divergence from the true value. Let us first assume that we have an optimal Markov chain to estimate the ratio $\frac{\Pi}{T^2}$, which increases with the non-uniformity of the distribution. We can then consider a simple graph with one node, one variable, and one loop that increments that variable. The corresponding Markov chain has a single parameter: the probability p of taking the loop edge. The path then has probability $(1 - p) \times p^i$ to have length $i < B$, and probability p^B to have length B . Using Theorem 4 from [Wie05], a long but technically simple derivation shows that the optimal distribution to maximise T uses $p = \Theta\left((2n)^{\frac{1}{2n}}\right)$.

In such a case, $T \in \Theta\left(\sqrt{\frac{n}{\ln n}}\right)$. Empirical values confirm the divergence, with $T \approx 9.26$ for $n = 100$, and $T \approx 23.7$ for $n = 1000$. This is for the simplest CCFG possible — a single node with a single loop — and a greater divergence might be found on more complex CCFGs.

Although there are limits on the efficiency of this method, it can still be of interest to find lower bounds. However, we have not yet solved the problem of finding the optimal Markov chain. A first possibility is to start with all $w_e = 1$ and repeatedly draw random paths until we get a collision. At this point, the w_e are incremented on all edges e of the colliding path. We then update the Markov chain, with the probability of taking each edge e being proportional to $\frac{1}{w_e}$. This iteratively diminishes the probability of getting that collision again, which tends to increase T . If the graph is a tree, a simple inductive proof shows that this process converges towards a uniform distribution on all paths. A cycle is not necessary to have divergence, as it can also occur on some DAGs.

5 Discussion and open problems

We have introduced a model of computation graphs and a set of bounds on the length and number of paths, as well as a method to estimate the latter. There are many open questions in this model, but the critical ones seem to be the following:

- What is the convergence speed of the Markov chain algorithm? Can it be improved by drawing paths until we have more than single collision before incrementing the weights?
- Can we obtain a useful upper bound on the divergence?
- Can we tighten the bounds in the small n case?

Acknowledgements. This work was supported partly by the french PIA project “Lorraine Université d’Excellence”, reference ANR-15-IDEX-04-LUE.

References

- [All70] Frances E Allen. Control flow analysis. In *ACM Sigplan Notices*, volume 5, pages 1–19. ACM, 1970.
- [CP⁺00] Michael Camarri, Jim Pitman, et al. Limit distributions and random trees derived from the birthday problem with unequal probabilities. *Electronic Journal of Probability*, 5, 2000.
- [Mas92] Shigeru Mase. Approximations to the birthday problem with unequal occurrence probabilities and their application to the surname problem in Japan. *Annals of the Institute of Statistical Mathematics*, 44(3):479–499, 1992.
- [OLBC10] Frank W. J. Olver, Daniel W. Lozier, Ronald F. Boisvert, and Charles W. Clark. *NIST Handbook of Mathematical Functions*. Cambridge University Press, 2010.
- [Wey39] Hermann Weyl. On the volume of tubes. *American Journal of Mathematics*, 61(2):461–472, 1939.
- [Wie05] Michael J. Wiener. Bounds on birthday attack times. *IACR Cryptology ePrint Archive*, 2005:318, 2005.

List homomorphisms of signed graphs

Jan Bok¹, Richard Brewster², Pavol Hell³, and Nikola Jedličková⁴

¹ Computer Science Institute of Charles University, Prague, Czech Republic.

² Mathematics and Statistics, Thompson Rivers University, Kamloops, B.C., Canada.

³ School of Computing Science, Simon Fraser University, Burnaby, B.C., Canada.

⁴ Department of Applied Mathematics, Charles University, Prague, Czech Republic.

EXTENDED ABSTRACT

In the talk, we are interested in classifying the computational complexity of list homomorphism problem for signed graphs.

Signed graphs were introduced by Zaslavsky in the 1980s [2]. A *signed graph* is an undirected graph G together with a signing function $\sigma : E(G) \rightarrow \{+, -\}$. We denote such a graph as a pair (G, Σ) , where $\Sigma = \sigma^{-1}(-)$. Loops and parallel edges are allowed in signed graphs. However, it is assumed that there is at most one positive and at most one negative edge with the same endpoints.

Let us also define the *switching* operation. This operation can be applied to any vertex of a signed graph and it results in multiplying signs of all its incident edges by -1 . We say that two graphs are *switching-equivalent* if we can get one to the other by a sequence of switchings.

The sign of a cycle is defined as the product of the signs of all edges on the cycle. We then distinguish between a *negative* cycle and a *positive* cycle. We say that a signed graph is *balanced* if every cycle in the graph is positive. It is known [2] that a signed graph is balanced if and only if it is switching-equivalent to a signed graph with all edges positive. We say that a signed graph is *anti-balanced* if it is switching equivalent to a signed graph with all edges negative.

We can finally define the main definition — *homomorphism of signed graphs*.

Definition 1 We say that $f : V(G) \rightarrow V(H)$ is a homomorphism from signed graph (G, Σ) to (H, Π) if there exists a signed graph (G, Σ') switching-equivalent to (G, Σ) such that $f(u)f(v) \in E(H)$ whenever $uv \in E(G)$ and such that $uv \in \Sigma'$ if and only if $f(u)f(v) \in \Pi$.

We note that without the possibility of switching we get homomorphisms of 2-edge-colored graphs.

Definition 2 Let (H, Π) be a fixed signed graph. The $\text{S-HOM}(H, \Pi)$ is defined as follows:

INPUT: A signed graph (G, Σ) .
QUESTION: Is there a signed homomorphism of (G, Σ) to (H, Π) ?

The problem was extensively studied in the last decade, see for example [3, 4, 9].

One of the most important results is settling the dichotomy of $\text{S-HOM}(H, \Pi)$ by Brewster and Siggers [9], conjectured by Brewster, Foucaud, Hell and Naserasr [4]. To state the result of Brewster and Siggers, we give a definition of *s-core*.

Definition 3 A signed graph (G, Σ) is a *s-core* if every homomorphism $f : (G, \Sigma) \rightarrow (G, \Sigma)$ is a bijection.

Theorem 4 [9] The problem $\text{S-HOM}(H, \Pi)$ is polynomial if (H, Π) has a *s-core* with at most 2 edges and NP-complete otherwise.

We are working on proving the dichotomy, and obtaining the concrete classification, of the complexity of the natural extension of this problem to its list version.

List versions of homomorphism problems have been much studied for non-signed graphs and digraphs. Dichotomies and concrete classifications of complexity for the list homomorphism problem are known for reflexive graphs [6], irreflexive graphs [7], arbitrary graphs

[8], and arbitrary digraphs [10]; and dichotomy is known for even more general relational structures [1].

The definition of our studied problem is the following.

Definition 5 *Let (H, Π) be a fixed signed graph. The LIST-S-HOM(H, Π) problem is defined as follows:*

INPUT: *A signed graph (G, Σ) with lists $L(v) \subseteq V(H)$ for every $v \in V(G)$.*
 QUESTION: *Does there exist a homomorphism f from (G, Σ) to (H, Π) such that $f(v) \in L(v)$ for every $v \in V(G)$?*

It is clear that any NP-complete case of S-HOM(H, Π) remains NP-complete for LIST-S-HOM(H, Π) so by Theorem 4, we may focus on signed graphs (H, Π) whose s-cores have at most two edges. There are, however, many complex signed graphs with this property.

We don't yet have a full classification of the complexity, and we report here some partial progress. In particular, we have a complete classification if the signed graph (H, Π) has no vertex with both a positive and a negative loop. We also discuss some partial results for the case when there are only one or two such vertices.

We partition the vertices of the target graph H into four parts:

- A — the vertices having both positive and negative loops,
- B — the vertices with positive loops and no negative loops,
- C — the vertices with negative loops and no positive loops,
- D — the vertices with no loops.

A *double edge* is a pair of edges, one positive one negative, with the same endpoints.

The complexity of LIST-S-HOM(H, Π) for the case when A is empty is below. Recall the definition of a *bi-arc* graph.

Definition 6 [8] *Let C be a circle with two specified points p and q on C . A bi-arc is an ordered pair of arcs (N, S) on C such that N contains p but not q , and S contains q but not p . A graph H is bi-arc graph if there is a family of bi-arcs $\{(N_x, S_x) : x \in V(H)\}$ such that, for any $x, y \in V(H)$, not necessarily distinct, the following hold:*

- if x and y are adjacent, then neither N_x intersects S_y nor N_y intersects S_x ;
- if x and y are not adjacent, then both N_x intersects S_y and N_y intersects S_x .

Theorem 7 *Let (H, Π) be a connected signed graph partitioned into A, B, C, D as in the previous paragraph. The following dichotomy holds for the problem LIST-S-HOM(H, Π) if A is empty.*

1. *If both B and C are non-empty, the problem is NP-complete.*
2. *If $B \cup D$ is non-empty and C is empty, the problem is polynomial if (H, Π) is balanced and H is a bi-arc graph.*
3. *If $C \cup D$ is non-empty and B is empty, the problem is polynomial if (H, Π) is anti-balanced and H is a bi-arc graph.*
4. *All other cases are NP-complete.*

In the case of A being non-empty, we have some partial results. Namely the following is the most important.

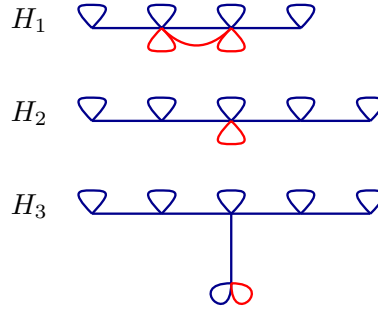

Figure 1: The forbidden patterns from Theorem 9. Negative edges are in red, positive edges in blue.

Theorem 8 For a given signed graph (H, Π) the problem LIST-S-HOM(H, Π) is NP-complete if the subgraph of H induced by its A part is not an interval graph with double edges.

For the case when A has one or two vertices, the following information is very useful. We define the three graphs H_1, H_2, H_3 (see Fig. 1) as forbidden patterns.

Theorem 9 If a given signed graph (H, Π) contains any of the graphs H_1, H_2, H_3 as an induced subgraph after some switching, the problem LIST-S-HOM(H, Π) is NP-complete.

In the presentation, we will discuss the details of proofs and we will also talk about other related results we obtained.

Acknowledgments The first author has received funding from the European Union’s Horizon 2020 project H2020-MSCA-RISE-2018: Research and Innovation Staff Exchange. The first author was also supported by Charles University Grant Agency project 1580119. The third and fourth author were also partially supported by the third author’s NSERC Canada Discovery grant.

References

- [1] A. A. Bulatov. Complexity of conservative constraint satisfaction problems. **ACM Trans. Comput. Log.** 12:24–66, 2011.
- [2] T. Zaslavsky. Signed graphs. **Discrete Appl. Math.**, 4:47–74, 1982.
- [3] F. Foucaud and R. Naserasr. The complexity of homomorphisms of signed graphs and signed constraint satisfaction. **Proceedings of the 11th Latin American Symposium on Theoretical Informatics 2014, LATIN 2014, LNCS**, 8392:526–537, 2014.
- [4] Brewster, R., Foucaud, F., Hell, P., and Naserasr, R. The complexity of signed graph and edge-coloured graph homomorphisms. **Discrete Math.** 340:223–235, 2017.
- [5] Feder, T., and Hell, P. List homomorphisms to reflexive graphs. *Journal of Combinatorial Theory, Series B* 72, 2 (1998), 236–250.
- [6] Feder, T., and Hell, P. List homomorphisms to reflexive graphs. **Journal of Combinatorial Theory, Series B** 72, 2: (1998), 236–250.
- [7] Feder, T., Hell, P., and Huang, J. List homomorphisms and circular arc graphs. *Combinatorica*, 19:487–505, 1999.

- [8] Feder, T., Hell, P., and Huang, J. Bi-arc graphs and the complexity of list homomorphisms. **Journal of Graph Theory**, 42:61–80, 2013.
- [9] Brewster, C. and Siggers, M. A complexity dichotomy for signed H -colouring **Discrete Math.** 341:2768-2773, 2018.
- [10] Hell, P., and Rafiey, A. The dichotomy of list homomorphisms for digraphs. **Proceedings of the Twenty-second annual ACM-SIAM symposium on Discrete Algorithms** 1703–1713, 2011.

Extending Partial Orderings of Adjusted Interval Digraphs

Jan Bok¹, Pavol Hell², and Nikola Jedličková³

¹ Computer Science Institute of Charles University, Prague, Czech Republic.

² School of Computing Science, Simon Fraser University, Burnaby, B.C., Canada.

³ Department of Applied Mathematics, Charles University, Prague, Czech Republic.

EXTENDED ABSTRACT

Adjusted interval graphs have been studied as the right digraph analogue of interval graphs. For interval graphs there are polynomial algorithms to extend a partial representation by given intervals into a full interval representation. We will introduce a similar problem – *extending partial ordering*. We provide a polynomial algorithm to extend a partial ordering of adjusted interval digraphs.

The classical definition of interval digraphs was given by West et al. [1].

Definition 1 *A digraph H is an interval digraph if there exist a family of source intervals $\{I_v | v \in V(H)\}$ and a family of sink intervals $\{J_v | v \in V(H)\}$ such that the source interval I_u intersects the sink interval J_v if and only if $(u, v) \in E(H)$.*

The following more restrictive definition given by Feder et al. [2] seems to define a more useful analogue.

Definition 2 *An adjusted interval digraph is an interval digraph such that the intervals I_v and J_v can be chosen to have the same left-point for each vertex $v \in V(H)$.*

Note that an interval digraph does not have to be reflexive but adjusted interval digraphs are always reflexive. Adjusted interval digraphs were defined in connection with studying of computational complexity of list homomorphisms [2]. We define n as the number of vertices of H and m as the number of edges of H . The first algorithm for recognition of adjusted interval digraphs was introduced in [3] with time complexity $O(m^2 + n^2)$. Subsequently, the algorithm was improved by Takaoka [7] to cubic time – $O(n^3)$.

Definition 3 *A min ordering of H is a linear ordering $<$ of $V(H)$ that satisfies the following property. If $(u, v) \in E(H)$ and $(u', v') \in E(H)$, then $(\min(u, u'), \min(v, v')) \in E(H)$.*

Feder et al. [3] showed that H is an adjusted interval digraph if and only if H has a min ordering.

It is sometimes of interest to not find an arbitrary representation, but one that uses predefined intervals. Klavík et al. [5, 6] defined and studied *partial representation extension problem* REPEXT(\mathcal{C}) for fixed class of intersection graphs \mathcal{C} . A *partial representation* R' of graph G is a representation of an induced subgraph G' of G . For a given graph G and a partial representation R' , they ask if there is a representation R of G such that for every $v \in V(G')$ holds $R(v) = R'(v)$. For more information about this problem we refer reader to [4].

We are working on the natural analogue of this concept for adjusted interval digraphs. In view of the result of Feder et al. [3] mentioned above, it is natural to consider first a similar (but easier) problem of extending a partial ordering.

Extending partial orderings problem for adjusted interval digraphs is defined as follows. For a given reflexive digraph H and a set of pre-ordered pairs of vertices $P \subseteq \{(u, v) | u, v \in V(H), u \neq v\}$, we ask if there exist a min ordering R of vertices of H such that $(u, v) \in P$ implies $u < v$ in R . We say that R *extends* P .

Using the methods of [6], it can be shown that the analogous problem for extending interval orderings of undirected interval graphs has a linear time algorithm.

Our main contribution is the following theorem.

Theorem 4 *The problem of extending partial ordering of adjusted interval digraph can be solved in polynomial time with an algorithm running in $O(n^5)$ time.*

We will need two auxiliary graphs for our algorithm — a *pair digraph* by Feder et al. and an *implication digraph* by Takaoka.

Definition 5 [3] *Let H be a reflexive digraph. The pair digraph H^+ associated with H is defined as $V(H^+) = \{(u, v) | u, v \in V(H), u \neq v\}$ and for any vertices u, v, u', v' of H the following holds: $(u, v) \rightarrow (u', v')$ and $(v', u') \rightarrow (v, u)$ in H^+ if and only if*

- $(u, u'), (v, v') \in E(H)$ and $(u, v') \notin E(H)$, or
- $(u', u), (v', v) \in E(H)$ and $(v', u) \notin E(H)$.

Definition 6 [7] *Let H be a reflexive digraph. The implication graph H^* of H is a digraph such that $V(H^*) = \{(u, v) | u, v \in V(H), u \neq v\}$ and for any three vertices u, v, w of H : $(u, v) \rightarrow (w, v)$ and $(v, w) \rightarrow (v, u)$ in H^* if and only if*

- $(u, w) \in E(H)$ and $(u, v) \notin E(H)$, or
- $(w, u) \in E(H)$ and $(v, u) \notin E(H)$.

The algorithm is based on using the following theorem, which is adapted from a similar theorem for H^+ [3].

Theorem 7 *Let H^* be an implication graph of a reflexive digraph H . Then H is an adjusted interval digraph if and only if the vertices of H^* can be partitioned into two sets D, D' such that the following properties hold.*

1. $(x, y) \in D$ if and only if $(y, x) \in D'$,
2. if $(x, y) \in D$ and $(x, y) \rightarrow (w, z) \in H^*$ then $(w, z) \in D$,
3. if $(x, y), (y, z) \in D$ then $(x, z) \in D$.

The algorithm tries to divide the vertices of an implication graph H^* into the sets D and D' with regards to the pre-ordered pairs or returns that it is not possible to do that.

This is the first step to solve the partial representation extension problem for adjusted interval digraphs. The authors of this abstract are currently working on this problem.

Acknowledgement. The first author has received funding from the European Union's Horizon 2020 project H2020-MSCA-RISE-2018: Research and Innovation Staff Exchange. The third author was supported by the Czech Science Foundation (GA-ČR) project 19-17314J and by Charles University Grant Agency project 1198419. The second and third author were also partially supported by the second author's NSERC Canada Discovery grant.

References

- [1] S. Das, M. Sen, A. B. Roy, D.B. West. Interval digraphs: An analogue of interval graphs. **Journal of Graph Theory**, 13(2):189–202, 1989.
- [2] T. Feder, P. Hell, J. Huang, A. Rafiey. Adjusted interval digraphs. **Electronic Notes in Discrete Mathematics**, 32:83–91, 2009.
- [3] T. Feder, P. Hell, J. Huang, A. Rafiey. Interval graphs, adjusted interval digraphs, and reflexive list homomorphisms. **Discrete Applied Mathematics**, 160(6):697–707, 2012.
- [4] P. Klavík. Extension properties of graphs and structures. 2017.

- [5] P. Klavík, J. Kratochvíl, T. Vyskočil. Extending partial representations of interval graphs. **LNCS; International Conference on Theory and Applications of Models of Computation**, 276–285, 2011.
- [6] P. Klavík, J. Kratochvíl, Y. Otachi, T. Saitoh, T. Vyskočil. Extending partial representations of interval graphs. **Algorithmica**, 78(3):945–967, 2017.
- [7] A. Takaoka. A recognition algorithm for adjusted interval digraphs. arXiv preprint arXiv:1810.06162, 2018.

Distributed recoloring on trees¹

Marthe Bonamy¹, Paul Ouvrard¹, Mikaël Rabie², Jukka Suomela³, and Jara Uitto⁴

¹ LaBRI-CNRS, University of Bordeaux, France ² LIP6, université Paris Sorbonne ³ Aalto University ⁴ ETH Zürich and University of Freiburg

EXTENDED ABSTRACT

Recoloring problems. Reconfigurations problems arise when, we are given an instance of a problem and we want to find a step-by-step transformation (called *reconfiguration sequence*) between two feasible solutions such that all intermediate solutions are also feasible.

Interest in combinatorial reconfiguration steadily increased during the last decade. Reconfiguration of several problems, including COLORING [1, 2, 3], INDEPENDENT SET [4, 5, 6], DOMINATING SET [7, 8, 9] have been studied. For an overview of recent results on reconfiguration problems, the reader is referred to the surveys of van den Heuvel [12] and Nishimura [13].

Here, we focus on graph *recoloring*: we are given a graph G and two proper k -colorings of G , let us call them s (for source) and t (for target), and the task is to find a way to turn s into t by changing the color of one vertex at a time, such that each intermediate step is a proper coloring. More formally, the task is to find a sequence of proper k -colorings x_0, x_1, \dots, x_L such that $x_0 = s$ and $x_L = t$, and x_i is obtained from x_{i-1} by changing the color of exactly one vertex. Such problems have been studied extensively from the perspective of graph theory and classical centralized algorithms, but the problems are typically inherently global and solutions (when they exist) are long, i.e., L is large in the worst case.

In this work we introduce recoloring problems in a *distributed* setting. We show that there are natural relaxations of the problem that are attractive from the perspective of distributed graph algorithms: they admit solutions that are short and that can be found *locally* (e.g., in sublinear number of rounds). Distributed recoloring problems are closely related to classical symmetry-breaking problems that have been extensively studied in the area of distributed graph algorithms, but as we will see, they also introduce new kinds of challenges.

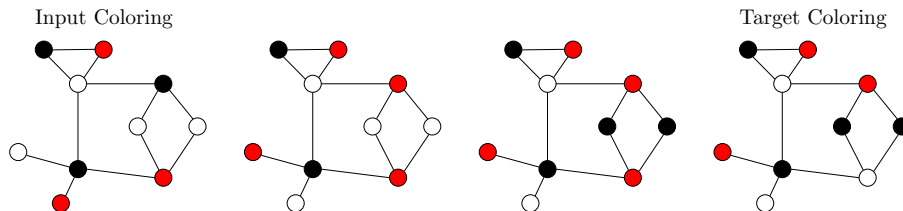

Figure 1: Distributed recoloring: the input coloring s can be seen on the left and the target coloring t on the very right. The illustration shows one possible way to reach the target coloring in three steps by, in each step, changing the colors of an independent set.

Distributed recoloring. We will work in the LOCAL model of distributed computing: Each vertex $v \in V$ of the input graph $G = (V, E)$ is a computer, and each edge $e \in E$ represents a communication link between two computers. Computation proceeds in synchronous rounds: each vertex sends a message to each of its neighbors, receives a message from each of its neighbors, and updates its local state. Eventually, all vertices have to announce their local outputs and stop; the running time of the algorithm is the number of communication rounds until all vertices stop. We assume that the algorithm is deterministic, and each vertex is labeled with a unique identifier.

¹This talk presents some results of our paper *Distributed recoloring* published in the proceedings of DISC'2018. See <https://arxiv.org/abs/1802.06742> for the full version of the paper.

In *distributed recoloring*, each vertex $v \in V$ is given two colors, an *input color* $s(v)$ and a *target color* $t(v)$. It is guaranteed that both s and t form a proper coloring of G , that is, $s(u) \neq s(v)$ and $t(u) \neq t(v)$ for all $\{u, v\} \in E$. Each vertex $v \in V$ has to output a finite *recoloring schedule* $x(v) = \langle x_0(v), x_1(v), \dots, x_\ell(v) \rangle$ for some $\ell = \ell(v)$. For convenience, we define $x_i(v) = x_\ell(v)$ for $i > \ell(v)$. We say that the vertex *changes its color at time* $i > 0$ if $x_{i-1}(v) \neq x_i(v)$; let S_i be the set of vertices that change their color at time i . Define $L = \max_v \ell(v)$; we call L the *length* of the solution. A solution is feasible if the following holds:

1. $x_0 = s$ and $x_L = t$,
2. x_i is a proper coloring of G for all i ,
3. S_i is an independent set of G for all i .

The key differences between distributed recoloring and classical recoloring are:

1. Input and output are given in a distributed manner: no vertex knows everything about G , s , and t , and no vertex needs to know everything about x_i or the length of the solution L .
2. We do not require that only one vertex changes its color; it is sufficient that adjacent vertices do not change their colors simultaneously.

See Figure 1 for a simple example of distributed recoloring steps.

Note that a solution to distributed recoloring is locally checkable in the following sense: to check that a solution is feasible, it is enough to check independently for each edge $uv \in E$ that the recoloring sequences $x(u)$ and $x(v)$ are compatible with each other, and for each vertex $v \in V$ that $x(v)$ agrees with $s(v)$ and $t(v)$. However, distributed recoloring is not necessarily an LCL problem [14] in the formal sense, as the length of the output per vertex is not a priori bounded.

We emphasize that we keep the following aspects well-separated: what is the complexity of *finding* the schedule, and how *long* the schedules are. Hence it makes sense to ask, e.g., if it is possible to find a schedule of length $O(1)$ in $O(\log n)$ rounds (note that the physical reconfiguration of the color of the vertex may be much slower than communication and computation).

Recoloring with extra colors. Recoloring is computationally very hard, as solutions do not always exist, and deciding whether a solution exists is PSPACE-hard. It is in a sense analogous to problems such as finding an *optimal* vertex coloring of a given graph; such problems are not particularly interesting in the LOCAL model, as the complexity is trivially global. To make the problem much more interesting we slightly relax it.

We define a $k + c$ *recoloring problem* (a.k.a. *k-recoloring with c extra colors*) as follows:

- We are given colorings with $s(v), t(v) \in [k]$.
- All intermediate solutions must satisfy $x_i(v) \in [k + c]$.

Here we use the notation $[n] = \{1, 2, \dots, n\}$.

The problem of $k + c$ recoloring is meaningful also beyond the specific setting of distributed recoloring. For example, here is an example of a very simple observation:

Lemma 1. *Recoloring with 1 extra color is always possible in any bipartite graph, with a distributed schedule of length $L = 3$.*

Proof. Let the bipartition be $V = V_1 \cup V_2$. First each vertex $v \in V_1$ switches to $k + 1$, then each $v \in V_2$ switches to color $t(v)$, and finally each $v \in V_1$ switches to color $t(v)$. \square

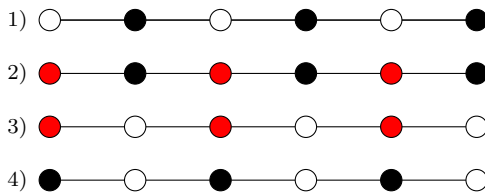

Figure 2: In the input graph, a bipartition is given. Therefore, the target coloring can be reached by using one extra color in three steps.

Incidentally, it is easy to extend this result to show that k -recoloring with $c = \chi - 1$ extra colors is always possible with a schedule of length $O(c)$ in a graph with chromatic number χ , and in particular k -recoloring with $c = k - 1$ extra colors is trivial. Figure 2 gives an illustration of recoloring a bipartite graph with one extra color.

As a corollary, we can solve distributed $k + 1$ recoloring in trees in $O(n)$ rounds, with a schedule of length $O(1)$: simply find a bipartition and apply the above lemma. However, is this optimal? Clearly finding a bipartition in a tree requires $\Omega(n)$ rounds, but can we solve recoloring with 1 extra color strictly faster?

These are examples of problems that we study in this work. We initiate the study of distributed complexity of recoloring, with the ultimate objective of finding a complete characterization of graph families and parameters k , c , and L such that distributed $k + c$ recoloring with schedules of length L can be solved efficiently in a distributed setting.

Our results. In the remainder of this article, we focus on 3-recolorings of trees on n vertices. Let C_i be the set of vertices colored with color i . If we allow two extra colors, the problem becomes trivial by proceeding as follows: (i) recolor C_1 with the first extra color 4, (ii) recolor C_2 with the second extra color 5, (iii) recolor each vertex in C_3 with its final color, and (iv) recolor each vertex in C_4 and C_5 to its target color in two more steps. Therefore, the length of the schedule is five and no communication is needed at all.

On the other hand, if we do not allow any extra color, we can still recolor any 3-coloring α into another one β . More precisely, we have the following:

Lemma 2. *For every tree T with radius at most p and for any two 3-colorings α, β of T , we can compute in $O(p)$ rounds how to 3-recolor T from α to β with a schedule of length $O(p)$.*

Note that this result is optimal since 3-recoloring paths requires $\Omega(n)$ rounds and produces schedules of length $\Omega(n)$ in the worst case.

We finally consider 3-recoloring of trees with one extra color and prove the following:

Theorem 3. *For any $k \in \mathbb{N}$, for every tree T on n vertices, for any two k -colorings α, β of T , we can compute in $O(\log n)$ rounds how to recolor T from α to β with 1 extra color and a schedule of length $O(1)$.*

The key ingredient to prove Theorem 3 is to find an independent set with some desirable properties. More formally, we prove that for any tree T , we can compute in $O(\log n)$ rounds a maximal independent set S of T such that $T \setminus S$ only has connected components on one or two vertices. To find this independent set, we use a simple modification of the *rake and compress* method by Reif and Miller [15]. More precisely, we iterate rake and compress operations, and label vertices based on the step at which they are reached. We then use the labels to compute this special independent set.

Once this independent set computed, recoloring T from α to β becomes trivial: (i) we recolor each vertex in S with the extra color, (ii) we give to each vertex in $T \setminus S$ its final color: this is possible without the extra color since the maximum degree in $T \setminus S$ is at most 1, and finally (iii) recolor each vertex in S with its target color.

References

- [1] Marthe Bonamy, Nicolas Bousquet, Carl Feghali, and Matthew Johnson. On a conjecture of mohar concerning kempe equivalence of regular graphs. **Journal of Combinatorial Theory, Series B**, 135:179 – 199, 2019.
- [2] Luis Cereceda, Jan van den Heuvel, and Matthew Johnson. Connectedness of the graph of vertex-colourings. **Discrete Mathematics**, 308(5):913 – 919, 2008. Selected Papers from 20th British Combinatorial Conference.
- [3] Carl Feghali. Paths between colourings of sparse graphs. **European Journal of Combinatorics**, 75:169 – 171, 2019.
- [4] Paul S. Bonsma. Independent set reconfiguration in cographs and their generalizations. **Journal of Graph Theory**, 83(2):164–195, 2016.
- [5] Nicolas Bousquet, Arnaud Mary, and Aline Parreau. Token jumping in minor-closed classes. In Ralf Klasing and Marc Zeitoun, editors, **Fundamentals of Computation Theory**, pages 136–149, Berlin, Heidelberg, 2017. Springer Berlin Heidelberg.
- [6] Daniel Lokshtanov and Amer E. Mouawad. The complexity of independent set reconfiguration on bipartite graphs. In **Proceedings of the Twenty-Ninth Annual ACM-SIAM Symposium on Discrete Algorithms, SODA 2018, New Orleans, LA, USA, January 7-10, 2018**, pages 185–195, 2018.
- [7] Takehiro Ito, Erik D. Demaine, Nicholas J.A. Harvey, Christos H. Papadimitriou, Martha Sideri, Ryuhei Uehara, and Yushi Uno. On the complexity of reconfiguration problems. **Theoretical Computer Science**, 412(12):1054 – 1065, 2011.
- [8] Daniel Lokshtanov, Amer E. Mouawad, Fahad Panolan, M.S. Ramanujan, and Saket Saurabh. Reconfiguration on sparse graphs. **Journal of Computer and System Sciences**, 95:122 – 131, 2018.
- [9] Amer E. Mouawad, Naomi Nishimura, Venkatesh Raman, Narges Simjour, and Akira Suzuki. On the parameterized complexity of reconfiguration problems. **Algorithmica**, 78(1):274–297, May 2017.
- [10] Parikshit Gopalan, Phokion G. Kolaitis, Elitza Maneva, and Christos H. Papadimitriou. The connectivity of boolean satisfiability: Computational and structural dichotomies. **SIAM J. Comput.**, 38(6):2330–2355, March 2009.
- [11] A. Mouawad, N. Nishimura, V. Pathak, and V. Raman. Shortest reconfiguration paths in the solution space of boolean formulas. **SIAM Journal on Discrete Mathematics**, 31(3):2185–2200, 2017.
- [12] Jan van den Heuvel. The complexity of change. In Simon R. Blackburn, Stefanie Gerke, and Mark Wildon, editors, *Surveys in Combinatorics*, volume 409 of **London Mathematical Society Lecture Note Series**, pages 127–160. Cambridge University Press, 2013.
- [13] Naomi Nishimura. Introduction to reconfiguration. **Algorithms**, 11(4):52, 2018.
- [14] Moni Naor and Larry Stockmeyer. What can be computed locally? **SIAM Journal on Computing**, 24(6):1259–1277, 1995.
- [15] Gary L. Miller and John H. Reif. Parallel tree contraction part 1: Fundamentals. **Advances in Computing Research**, 5:47–72, 1989.

Planar Graphs with Girth 20 are Additively 3-Choosable

Axel Brandt ¹, Nathan Tenpas ², and Carl Yerger ³

¹ Northern Kentucky University, Highland Heights, KY, USA

² Vanderbilt University, Nashville, TN, USA

³ Davidson College, Davidson, NC, USA

EXTENDED ABSTRACT

1 Introduction

An *additive coloring* of a graph G is a labeling of the vertices of G with natural numbers such that two adjacent vertices have distinct sums of labels on their neighbors. The *additive coloring number* of G , denoted by $\chi_\Sigma(G)$, is defined to be the minimum natural number k for which G has an additive coloring using labels in $\{1, \dots, k\}$. We briefly mention that additive coloring was introduced in the literature as *lucky labeling* by Czerwiński, Grytczuk, and Żelazny [10]. It has also been referred to as *open distinguishing* by Axenovich et al. [4]. We direct the interested reader to [8] for a more detailed exposition of results in this area.

In 2009, Czerwiński, Grytczuk, and Żelazny conjectured the following:

Conjecture 1 ([10]) *For every graph G , $\chi_\Sigma(G) \leq \chi(G)$.*

This conjecture is open in general, and $\chi_\Sigma(K_n) = \chi(K_n)$ implies that the conjecture would be best possible if true. Of particular interest, there is currently no known constant bound for the class of bipartite graphs. The best known bound for the class of planar graphs is given by the following:

Theorem 2 ([5]) *If G is a planar graph, then $\chi_\Sigma(G) \leq 468$.*

Recently, significant progress has been made for planar graphs under certain girth assumptions. The *girth* of a graph G , denoted by $\text{girth}(G)$, is the length of the shortest cycle in G . Bartnicki et al. [5] use the existence of an I,F-partition, which we do not discuss here, to show that $\chi_\Sigma(G) \leq 4$ for planar graphs G with girth at least 13. Using an improved result on the existence of I,F-partitions [6], their result was later improved as follows:

Theorem 3 ([8]) *If G is a planar graph with girth at least 10, then $\chi_\Sigma(G) \leq 4$.*

A list version of additive coloring has been studied, and similar results have been obtained. A graph G is *additively k -choosable* if an additive coloring can be selected from any list assignment of natural numbers to the vertices of G where each list has at least k distinct elements. The *additive choice number* of G , denoted by $\text{ch}_\Sigma(G)$, is the minimum natural number k such that G is additively k -choosable. Ahadi and Dehghan [1] have shown that $\chi_\Sigma(G)$ and $\text{ch}_\Sigma(G)$ can be arbitrarily far apart.

Theorem 4 ([2]) *If G is a forest, then $\text{ch}_\Sigma(G) \leq 3$.*

Theorem 5 ([8]) *Let G be a planar graph with girth g . If $g \geq 5$, then $\text{ch}_\Sigma(G) \leq 19$. If $g \geq 6$, then $\text{ch}_\Sigma(G) \leq 9$. If $g \geq 7$, then $\text{ch}_\Sigma(G) \leq 8$. If $g \geq 26$, then $\text{ch}_\Sigma(G) \leq 3$.*

In [7] the authors provide a shorter proof for the girth 26 result of Theorem 5. Expanding on that approach and incorporating aspects of the original proof enables the result to be strengthened as follows:

Theorem 6 *If G is a planar graph with girth at least 20, then $\text{ch}_\Sigma(G) \leq 3$.*

2 Notation and Tools

As standard notation for proofs utilizing the discharging method, a j -, j^- -, or j^+ -*vertex* is a vertex with degree j , at most j , or at least j , respectively. Similarly, a j -, j^- -, or j^+ -*neighbor* of v is a j -, j^- -, or j^+ -vertex, respectively, adjacent to v .

For the remainder of this abstract, suppose G is a vertex-minimum counterexample to Theorem 6. That is, let G be a planar graph with girth at least 20 and $\text{ch}_\Sigma(G) \geq 4$ such that $\text{ch}_\Sigma(H) \leq 3$ for any graph H with $|V(H)| < |V(G)|$. By the nature of additive coloring, G is connected.

To show that G does not exist, we utilize the following from [8] as it applies to our main result, that is when $k = 3$ and $Q = \emptyset$:

Lemma 7 ([8], Lemma 3.1 Part b) *A vertex v in G with r 1-neighbors satisfies $1 + 2r \leq d(v)$.*

For $v \in V(G)$ and $S \subseteq V(G)$, let $\text{dist}(v, S)$ be the minimum distance from v to some vertex in S . As such, for a vertex v , define the *cycle distance* of v , denoted by $\text{cdist}(v)$, to be the minimum distance from v to a cycle of G , that is $\text{cdist}(v) := \min\{\text{dist}(v, V(C)) : C \text{ is a cycle in } G\}$. Note that this definition is well-defined because Theorem 4 implies G contains a cycle. The following appears in [7].

Lemma 8 ([7]) *Let v be a 1-vertex in G . Then $\text{cdist}(v) = 1$.*

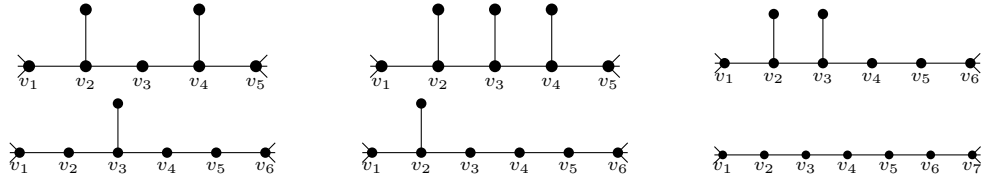

Figure 1: Configurations that do not appear in G : $P(1, 0, 1)$, $P(1, 1, 1)$, $P(1, 1, 0, 0)$, $P(0, 1, 0, 0)$, $P(1, 0, 0, 0)$, and $P(0, 0, 0, 0, 0)$.

The configurations in Figure 1 do not appear in G by Lemma 3.8 in [8]. Toward describing these and similar configurations, let $P(t_2, \dots, t_{n-1})$ be the path $v_1 \cdots v_n$ such that, for each i in $\{2, \dots, n-1\}$, the vertex v_i has t_i 1-neighbors and $d(v_i) = 2 + t_i$. Note that Lemma 7 implies that $t_i \leq 1$ for each such v_i . The following appears in [8].

Lemma 9 ([8]) *Any $P(t_2, \dots, t_{n-1})$ in G satisfies $n \leq 6$.*

For $P(t'_2, \dots, t'_{m-1})$ with underlying path $v'_1 \cdots v'_m$, let $P(t_2, \dots, t_{n-1}) \odot P(t'_2, \dots, t'_{m-1})$ denote the graph obtained from $P(t_2, \dots, t_{n-1})$ and $P(t'_2, \dots, t'_{m-1})$ by identifying v_n and v'_1 . See Figure 2 for an example of this construction.

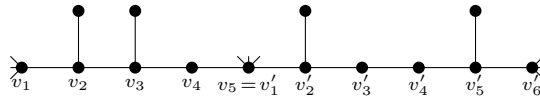

Figure 2: An image of $P(1, 1, 0) \odot P(1, 0, 0, 1)$ with respective underlying paths $v_1 \cdots v_5$ and $v'_1 \cdots v'_6$.

As in [7], define the *thread degree* of a vertex v , denoted by $d_{2^+}(v)$, as the number of 2^+ -neighbors of v . A *hub* vertex is a vertex v with $d_{2^+}(v) \geq 3$, and a *stable* vertex is a hub vertex contained in a cycle. Define a (u, v) -*thread* to be a path whose endpoints u and v are hub vertices, and whose internal vertices are 2-vertices. In Figure 3, all labeled vertices are hubs, but v and w are not stable.

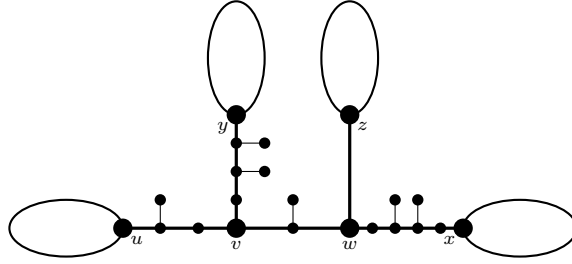

Figure 3: A visual depiction of G where the ellipses represent the rest of G , each of which includes a cycle containing u , x , y , and z , respectively, and are only connected by paths containing at least three labeled vertices.

Note that Lemma 8 implies that the set of 2-vertices of G is a subset of the set of internal vertices of (u, v) -threads in G . Also, every 1-vertex of G is either adjacent to a hub vertex, or in some $P(t_2, \dots, t_{n-1})$.

3 Some Additional Structure

In this section we describe additional structural properties of G . Specifically, we enumerate some configurations that do not appear in G . We will utilize the following result of Alon:

Theorem 10 (Combinatorial Nullstellensatz [3]) *Let f be a polynomial of degree t in m variables over a field \mathbb{F} . If there is a monomial $\prod x_i^{t_i}$ in f with $\sum t_i = t$ whose coefficient is nonzero in \mathbb{F} , then f is nonzero at some point of $\prod T_i$, where each T_i is a set of $t_i + 1$ distinct values in \mathbb{F} .*

We follow the approach of [8], which builds a polynomial whose nonzero solutions satisfy the restrictions for additive coloring.

The following lemmas are obtained using Mathematica to loop through all possible configurations. Toward verifying the polynomials cover all possibilities, note that Lemma 7 implies that vertices with thread degree 3 have at most two 1-neighbors.

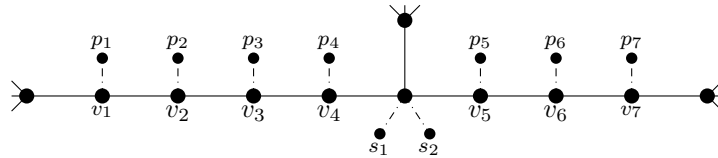

Figure 4: A picture of $P(t_2, t_3, t_4, t_5) \odot P(t'_2, t'_3, t'_4)$, where dash-dot edges indicate the potential of that edge's existence.

Lemma 11 *Let $v_1 \dots v_{13}$ be the underlying path of $P(t_2, t_3, t_4) \odot P(t'_2, t'_3, t'_4) \odot P(t''_2, t''_3, t''_4)$. If $d_{2^+}(v_5) = d_{2^+}(v_9) = 3$, then $P(t_2, t_3, t_4) \odot P(t'_2, t'_3, t'_4) \odot P(t''_2, t''_3, t''_4)$ does not appear in G .*

Lemma 12 *Let $v_1 \dots v_{10}$ be the underlying path of $P(t_2, t_3, t_4, t_5) \odot P(t'_2, t'_3, t'_4)$. If $d_{2^+}(v_6) = 3$, then $P(t_2, t_3, t_4, t_5) \odot P(t'_2, t'_3, t'_4)$ does not appear in G .*

Lemma 13 *Let $v_1 \dots v_{13}$ be the underlying path of $P(t_2, t_3, t_4, t_5) \odot P(t'_2, t'_3) \odot P(t''_2, t''_3, t''_4)$. If $d_{2^+}(v_6) = d_{2^+}(v_9) = 3$, then $P(t_2, t_3, t_4, t_5) \odot P(t'_2, t'_3) \odot P(t''_2, t''_3, t''_4)$ does not appear in G .*

4 Discharging Proof of Theorem 6

We construct a graph G' from G and use a discharging argument to show that G' , and thus G , does not exist. Our construction of G' from G follows these steps in order:

- (S1) Delete all 1-vertices of G .
- (S2) For all (u, v) -threads with a cut-edge, contract all edges of the (u, v) -thread.
- (S3) Replace all remaining (u, v) -threads with the edge uv .

Recall that G is simple, planar, connected, and has girth at least 20. Using Lemma 9, it is straightforward to show that G' is simple, planar, and connected with $\delta(G') \geq 3$ and $\text{girth}(G') \geq 4$. Thus G' is also 2-edge-connected.

Proposition 3.1 in [9] gives

$$\sum_{v \in V(G')} (d(v) - 4) + \sum_{f \in F(G')} (l(f) - 4) = -8.$$

Thus assigning each vertex v an initial charge $\mu(v) = d(v) - 4$ and each face f an initial charge $\mu(f) = l(f) - 4$ gives an initial total charge of -8 . Consider distributing charge from faces to vertices as follows:

- (R1) Each 3-vertex receives $\frac{1}{3}$ charge from each of its incident faces.

Distributing charge in this way results in every vertex and face of G' having a nonnegative final charge, for a total charge at least 0, which is an impossibility. This impossibility implies that G' does not exist, and, by construction, that G does not exist. Hence, no counterexample exists to Theorem 6.

References

- [1] A. Ahadi and A. Dehghan. The inapproximability for the $(0, 1)$ -additive number. *Discrete Math. Theor. Comput. Sci.*, 17(3):217–226, 2016.
- [2] S. Akbari, M. Ghanbari, R. Manaviyat, and S. Zare. On the lucky choice number of graphs. *Graphs Combin.*, 29(2):157–163, 2013.
- [3] N. Alon. Combinatorial Nullstellensatz. *Combin. Probab. Comput.*, 8(1-2):7–29, 1999. Recent trends in combinatorics (Mátraháza, 1995).
- [4] M. Axenovich, J. Harant, J. Przybyło, R. Soták, M. Voigt, and J. Weidelich. A note on adjacent vertex distinguishing colorings of graphs. *Discrete Appl. Math.*, 205:1–7, 2016.
- [5] T. Bartnicki, B. Bosek, S. Czerwiński, J. Grytczuk, G. Matecki, and W. Żelazny. Additive coloring of planar graphs. *Graphs Combin.*, 30(5):1087–1098, 2014.
- [6] A. Brandt, M. Ferrara, M. Kumbhat, S. Loeb, D. Stolee, and M. Yancey. I,F-partitions of sparse graphs. *European J. Combin.*, 57:1–12, 2016.
- [7] A. Brandt, N. Tenpas, and C. Yerger. An alternative approach for bounding the additive choice number of planar graphs. *Congressus Numeratium*, 231:157-163, 2018.
- [8] A. Brandt, J. White, and S. Jahanbekam. Additive list coloring of planar graphs with given girth. *Discussiones Mathematicae Graph Theory*, (Accepted, In Press).
- [9] D. W. Cranston and D. B. West. An introduction to the discharging method via graph coloring. *Discrete Math.*, 340(4):766–793, 2017.
- [10] S. Czerwiński, J. Grytczuk, and W. Żelazny. Lucky labelings of graphs. *Inform. Process. Lett.*, 109(18):1078–1081, 2009.

Trees Containing All the Odd-Degree Vertices

Kathie Cameron

Department of Mathematics, Wilfrid Laurier University, Canada

EXTENDED ABSTRACT

1 Introduction

All graphs in this paper are finite. A path or cycle in a graph G is called *hamiltonian* if it contains each vertex of G . A vertex of degree 1 in a tree is called a *leaf*. A graph is *eulerian* if every vertex has even degree. For definitions not stated, we follow [2].

In 1946, Bill Tutte [12] gave a beautiful short proof of Smith's Theorem:

Theorem 1 *Smith's Theorem.* *Let G be a 3-regular graph and let e be an edge of G . The number of hamiltonian cycles of G containing e is even.*

An obvious corollary of any theorem which says that the number of objects is even is: Given one of the objects, there exists another. Give one hamiltonian cycle containing e , Tutte's proof does not provide an algorithm for finding another.

In 1978, Andrew Thomason [9] extended Smith's Theorem to any graph where all vertices have odd degree:

Theorem 2 (Andrew Thomason, [9]) *Let G be a graph with at least 3 vertices and let $e = xy$ be an edge of G . Assume that all vertices except possibly x and y have odd degree. Then the number of hamiltonian cycles of G containing e is even.*

Andrew Thomason's proof constructs a graph $X(G)$ which he calls a lollipop graph such that, when G is simple, the odd-degree vertices of $X(G)$ correspond precisely to the hamiltonian cycles of G containing e , and when G has parallel edges, the odd-degree vertices of $X(G)$ correspond precisely to the hamiltonian paths of G containing e which are extendible to a hamiltonian cycle in an odd number of ways. This provides an algorithm for finding a second hamiltonian cycle containing e by walking in $X(G)$ from a given odd-degree vertex to another odd-degree vertex. Unfortunately, this elegant algorithm is exponential [3, 8, 13], even for 3-regular graphs. Jack Edmonds and I use the term *exchange graph* for a graph like Thomason's in which the odd-degree vertices correspond to the objects of interest. Many theorems which say that the number of objects is even can be proved by constructing an exchange graph [5].

Inspired by a result of Carsten Thomassen [10], I extended Thomason's Theorem to graphs in which no two even-degree vertices are adjacent [4] using an exchange graph proof:

Theorem 3 *Let G be a graph with an odd-degree vertex and where no two even-degree vertices are adjacent. Let e be an edge of G . Then the number of cycles containing e and all the odd-degree vertices of G is even.*

Shunichi Toida proved:

Theorem 4 (Shunichi Toida, [11]) *Let G be an eulerian graph. Then for any edge e , the number of cycles of G containing e is odd.*

Theorems 2 and 4 say that for a given edge e in a graph G , the number of cycles containing e and all the odd-degree vertices is even if all vertices of G have odd degree and is odd if all vertices of G have even degree. Carsten Thomassen and I showed that the parity of the number of cycles containing e and all the odd-degree vertices is even as soon as G has an odd-degree vertex:

Theorem 5 *Let G be a graph and let $e = xy$ be an edge of G . The number of cycles of G containing e and all the odd-degree vertices is odd if and only if G is eulerian.*

The proof in [7] is not algorithmic. In this paper, I give an exchange graph proof.

In 1986, Ken Berman [1] extended Thomason's Theorem where all vertices have odd degree to trees. Note that a hamiltonian cycle C containing edge $e = xy$ in graph G corresponds to a spanning tree $T = C \setminus e$ in $G \setminus e$ where x and y have degree 1 in T and all other vertices have degree 2 in T . Given a subgraph H of a graph G , we define the *excess degree* of a vertex v to be its degree in G minus its degree in H , that is, its degree in $G \setminus E(H)$. Ken Berman proved:

Theorem 6 (Ken Berman, [1]) *Let G be a graph and T a spanning tree of G such that each vertex has odd excess degree. Then there is an even number of spanning trees of G with the same degree as T at each vertex of G .*

Berman's proof is a counting argument. In 1999, Edmonds and I [5] extended Berman's Theorem and gave an exchange graph proof. We recently [6] further extended this to include Theorem 3.

Before stating the theorem, we need the following definitions.

Let G be a graph, B a set of even-degree vertices of G , and $A = V(G) \setminus B$. A tree T in G is called *good* if T contains all vertices of A and if each vertex of B which is in T has degree 2 in T . Let T^* be a good tree in G . A good tree T is called *T^* -similar* if each vertex of A has the same degree in T^* and in T .

Theorem 7 *Let G be a bipartite graph with bipartition (A, B) , where every vertex in B has even degree. Suppose T^* is a good tree such that some vertex of A has odd excess degree and each vertex of A which is not a leaf of T has odd excess degree. Then the number of T^* -similar trees is even.*

My main result is an extension of Theorem 7 to non-bipartite graphs, which includes Theorem 5.

Theorem 8 *Let G be a graph, B a set of even-degree vertices of G , and $A = V(G) \setminus B$. Suppose T^* is a good tree such that some vertex of A has odd excess degree and each vertex of A which is not a leaf of T has odd excess degree. Then the number of T^* -similar trees is even.*

I prove Theorem 8 by constructing an exchange graph. This provides an algorithm for finding a second T^* -similar tree. Analogous to our exchange graphs for Theorems 6 and 7, the exchange graph requires choosing a special vertex, and our hope is that if the algorithm is run in parallel for all choices of special vertex, it may be polynomial-time.

References

- [1] Kenneth A. Berman. Parity results on connected f -factors. In **Discrete Math.** 59(1-2):1-8, 1986.
- [2] J.A. Bondy and U. S. R. Murty. Graph theory. Graduate Texts in Mathematics, 244. Springer, New York, (2008).
- [3] Kathie Cameron. Thomason's algorithm for finding a second hamiltonian circuit through a given edge in a cubic graph is exponential on Krawczyk's graphs. In **Discrete Math.** 235(1-3):69-77, 2001.
- [4] Kathie Cameron. Cycles containing all the odd-degree vertices. International Conference on Graph Theory (ICGT), Lyon, France, July 2018.

- [5] Kathie Cameron and Jack Edmonds. Some graphic uses of an even number of odd nodes. In **Ann. Inst. Fourier (Grenoble)** 49(3):815–827, 1999.
- [6] Kathie Cameron and Jack Edmonds. A PPA episode of exchange graphs. To appear in **Discrete Appl. Math.**
- [7] Kathie Cameron and Carsten Thomassen. Cycles containing all the odd-degree vertices. To appear in **J. Combin. Theory (Ser. B)**
- [8] Adam Krawczyk. The complexity of finding a second Hamiltonian cycle in cubic graphs. **J. Comput. System Sci.** 58(3):641–647, 1999.
- [9] A. G. Thomason. Hamiltonian cycles and uniquely edge colourable graphs. In **Ann. Discrete Math.** 3:259–268, 1978.
- [10] Carsten Thomassen. Chords in longest cycles. In **J. Combin. Theory (Ser. B)** 129:148–157, 2018.
- [11] Toida, S. Properties of a Euler graph. In **J. Franklin Inst.** 295:343—345, 1973.
- [12] W. T. Tutte. On Hamiltonian circuits. In **J. London Math. Soc.** 21:98–101, 1946.
- [13] Liang Zhong. The complexity of Thomason’s algorithm for finding a second hamiltonian cycle. In **Bull. Aust. Math. Soc.** 98(1):18—26, 2018.

Large independent sets in triangle-free subcubic graphs; beyond planarity

*Wouter Cames van Batenburg*¹, *Jan Goedgebeur*², and *Gwenaël Joret*¹

¹ Département d'Informatique, Université Libre de Bruxelles, Brussels, Belgium

² Department of Applied Mathematics, Computer Science and Statistics, Ghent University, Ghent, Belgium, and Computer Science Department, University of Mons, Mons, Belgium

EXTENDED ABSTRACT

1 Introduction

All graphs in this extended abstract are undirected, finite, and simple. A subset X of vertices of a graph G is *independent* if no two vertices in X are adjacent in G . We let $\alpha(G)$ denote the maximum size of an independent set in G . A graph G is said to be *subcubic* if G has maximum degree at most 3, and *cubic* if G is 3-regular.

One of the first results about independent sets in subcubic triangle-free graphs is the following theorem of Staton [8] from 1979.

Theorem 1 (Staton [8]) *Let G be a subcubic triangle-free n -vertex graph. Then, $\alpha(G) \geq \frac{5}{14}n$.*

Different proofs of this result have appeared in the literature; see in particular Heckman and Thomas [5] for a short proof. The bound is best possible, as witnessed by the two cubic graphs on 14 vertices in Figure 1 (top left and top center). In fact, these two graphs are the only tight examples among connected graphs [4], which suggests that a better bound might hold for connected subcubic triangle-free graphs when n is not too small. Indeed, Fraughtnaugh and Locke [3] proved the following result in 1995.

Theorem 2 (Fraughtnaugh and Locke [3]) *Let G be a connected subcubic triangle-free n -vertex graph. Then, $\alpha(G) \geq \frac{11}{30}n - \frac{2}{15}$.*

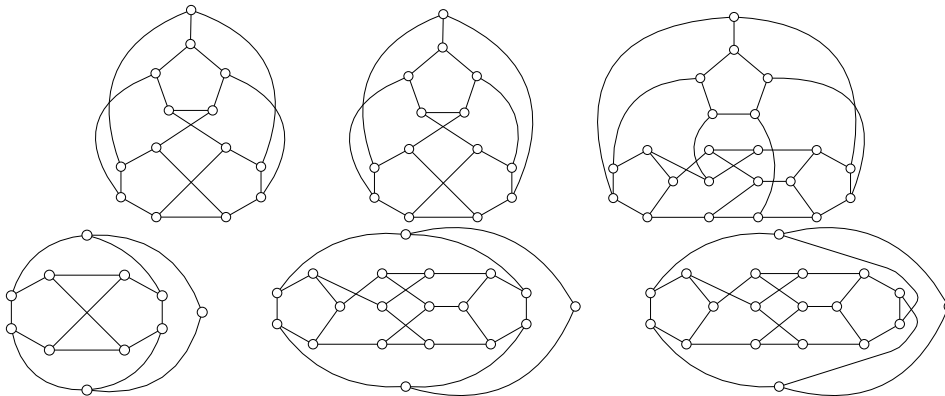

Figure 1: The graphs $F_{14}^{(1)}$, $F_{14}^{(2)}$, F_{22} , F_{11} , $F_{19}^{(1)}$ and $F_{19}^{(2)}$.

The factor $\frac{11}{30}$ is best possible, as shown by a construction of Fraughtnaugh and Locke [3] illustrated in Figure 2. Note that this construction is far from being 2-connected, thus it is natural to wonder whether the bound could be improved further under some extra connectivity assumption. In fact, already in 1986 Locke [7] conjectured that there are only finitely many 3-connected cubic triangle-free n -vertex graphs G with $\alpha(G) < \frac{3}{8}n$. Fraughtnaugh and Locke [3] made a similar conjecture under the assumption of 2-connectivity:

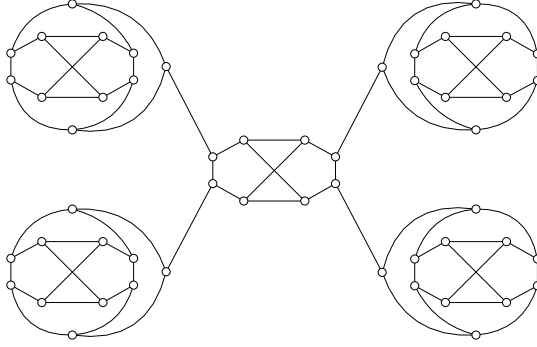

Figure 2: Construction of connected subcubic triangle-free n -vertex graphs G with $\alpha(G) = \frac{11}{30}n - \frac{1}{15}$: Start with a 4-regular tree, replace each internal node with a copy of B_8 (see Figure 3) and each leaf with a copy of F_{11} (see Figure 1), and link them using the degree-2 vertices. One can verify that for the resulting graph G , $\alpha(G)$ is three times the number of internal nodes plus four times the number of leaves. The construction is illustrated starting with a 4-leaf star.

Conjecture 3 (Fraughnaugh and Locke [3]) *Let G be a 2-connected subcubic triangle-free n -vertex graph. Then, $\alpha(G) \geq \frac{3}{8}n - \frac{1}{4}$.*

Bajnok and Brinkmann [2] investigated this conjecture using a computer search. While they found no counterexample in the range they considered, they also noted that they only found six 2-connected triangle-free subcubic n -vertex graphs G with $\alpha(G) < \frac{3}{8}n$, namely the graphs F_{11} , $F_{14}^{(1)}$, $F_{14}^{(2)}$, $F_{19}^{(1)}$, $F_{19}^{(2)}$, F_{22} from Figure 1. They conjectured that there are no other such graphs.

Conjecture 4 (Bajnok and Brinkmann [2]) *There are exactly six 2-connected triangle-free subcubic n -vertex graphs G with $\alpha(G) < \frac{3}{8}n$, namely F_{11} , $F_{14}^{(1)}$, $F_{14}^{(2)}$, $F_{19}^{(1)}$, $F_{19}^{(2)}$, F_{22} .*

Fraughnaugh and Locke [3], aware of the six graphs found in [2], formulated the following closely related conjecture.

Conjecture 5 (Fraughnaugh and Locke [3]) *If G is a subcubic triangle-free n -vertex graph containing none of F_{11} , $F_{14}^{(1)}$, $F_{14}^{(2)}$, $F_{19}^{(1)}$, $F_{19}^{(2)}$, F_{22} as subgraph, then $\alpha(G) \geq \frac{3}{8}n$.*

This conjecture implies Conjecture 4, because if G is 2-connected and contains some graph F among these six graphs as subgraph then G must be isomorphic to F .

Observe also that Conjecture 5 implies in particular that $\alpha(G) \geq \frac{3}{8}n$ holds for every planar subcubic triangle-free n -vertex graph G , since none of F_{11} , $F_{14}^{(1)}$, $F_{14}^{(2)}$, $F_{19}^{(1)}$, $F_{19}^{(2)}$, F_{22} is planar. This was conjectured by Albertson, Bollobás, Tucker [1] in 1976 and was still an open problem when the two papers [2, 3] were written. It was eventually proved by Heckman and Thomas [6] in 2006:

Theorem 6 (Heckman and Thomas [6]) *Let G be a subcubic triangle-free n -vertex planar graph on n vertices. Then, $\alpha(G) \geq \frac{3}{8}n$.*

2 Main result

In our recent work, we have proved that the conjectures mentioned above are true, thus in particular obtaining a strengthening of Theorem 6:

Theorem 7 (Main theorem) *Let G be a subcubic triangle-free n -vertex graph containing none of $F_{11}, F_{14}^{(1)}, F_{14}^{(2)}, F_{19}^{(1)}, F_{19}^{(2)}, F_{22}$ as (induced) subgraph. Then $\alpha(G) \geq \frac{3}{8}n$.*

Corollary 8 *Let G be a 2-connected subcubic triangle-free n -vertex graph. Then, $\alpha(G) \geq \frac{3}{8}n - \frac{1}{4}$. Moreover, $\alpha(G) \geq \frac{3}{8}n$ if G is not isomorphic to any of $F_{11}, F_{14}^{(1)}, F_{14}^{(2)}, F_{19}^{(1)}, F_{19}^{(2)}, F_{22}$.*

3 About the proof

Theorem 7 is proved by induction on the size of the graph. In order to help the induction go through, we need to prove a slightly stronger version of the theorem. Before stating it, we introduce a few definitions.

An edge e of a graph G is called *critical* if $\alpha(G - e) > \alpha(G)$. A graph is called critical if each of its edges is critical. In particular, K_1 is critical.

For a graph G , we define

$$\mu(G) := \frac{6|V(G)| - |E(G)|}{12} = \frac{1}{24}(9n_3 + 10n_2 + 11n_1 + 12n_0),$$

where n_i denotes the number of vertices of degree i in G .

In order to state our main technical theorem, we also need to mention two families of exceptional graphs, whose explicit inductive definition we will not provide in this extended abstract; please refer to the full paper, which we aim to put on arXiv before the start of this workshop. They are the family of *bad* graphs and the family of *dangerous* graphs. Let us just remark that the smallest dangerous graph is the five-cycle and the smallest bad graph is the 8-vertex graph depicted in figure 3.

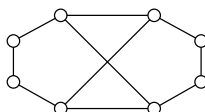

Figure 3: The smallest bad graph B_8 .

Theorem 9 (Main technical theorem) *Let G be a connected critical subcubic triangle-free graph which is not isomorphic to any of $F_{11}, F_{14}^{(1)}, F_{14}^{(2)}, F_{19}^{(1)}, F_{19}^{(2)}, F_{22}$. Then*

- $\alpha(G) = \mu(G) - \frac{1}{6}$ if G is bad
- $\alpha(G) \geq \mu(G) - \frac{1}{12}$ otherwise.

Furthermore, if G has at least three vertices of degree 2 and G has no bad subgraph, then

- $\alpha(G) = \mu(G) - \frac{1}{12}$ if G is dangerous
- $\alpha(G) \geq \mu(G)$ otherwise.

Theorem 7 follows from Theorem 9, as we now explain. The proof is by induction. We may assume that G is connected, since otherwise we are done by induction. We are similarly done by induction if $\alpha(G - e) = \alpha(G)$ holds for some edge $e \in E(G)$. Thus we may suppose that G is critical. If G is bad then it is easily checked from the inductive definition of bad graphs that $\mu(G) = \frac{3}{8}n + \frac{1}{6}$, and thus $\alpha(G) = \mu(G) - \frac{1}{6} = \frac{3}{8}n$ by Theorem 9. If G is not bad, then Theorem 9 gives

$$\alpha(G) \geq \mu(G) - \frac{1}{12} \geq \frac{3}{8}n - \frac{1}{12},$$

which can be rewritten as $3(8\alpha(G) - 3n) \geq -2$. However, since $\alpha(G)$ and n are both integers, it follows that $3(8\alpha(G) - 3n) \geq 0$, i.e. $\alpha(G) \geq \frac{3}{8}n$, as desired. This finishes the proof of Theorem 7 conditional on Theorem 9.

As a side remark, let us mention that we also recover Theorem 2 of Fraughnaugh and Locke [3] using our main technical theorem, with a slight improvement matching the construction in Figure 2:

Theorem 10 *Let G be a connected subcubic triangle-free n -vertex graph. Then, $\alpha(G) \geq \frac{11}{30}n - \frac{1}{15}$, unless G is isomorphic to $F_{14}^{(1)}$ or $F_{14}^{(2)}$, in which case $\alpha(G) = \frac{11}{30}n - \frac{2}{15}$.*

This answers a small question from [3].

References

- [1] M. Albertson, B. Bollobas, and S. Tucker. The independence ratio and maximum degree of a graph. pages 43–50. *Congressus Numerantium*, No. XVII, 1976.
- [2] B. Bajnok and G. Brinkmann. On the independence number of triangle free graphs with maximum degree three. *Journal of Combinatorial Mathematics and Combinatorial Computing*, 26:237–254, 1998.
- [3] K. Fraughnaugh and S. Locke. 11/30 (finding large independent sets in connected triangle-free 3-regular graphs). *Journal of Combinatorial Theory, Series B*, 65(1):51–72, 1995.
- [4] C. C. Heckman. On the tightness of the 5/14 independence ratio. *Discrete Mathematics*, 308(15):3169–3179, 2008.
- [5] C. C. Heckman and R. Thomas. A new proof of the independence ratio of triangle-free cubic graphs. *Discrete Mathematics*, 233(1):233–237, 2001.
- [6] C. C. Heckman and R. Thomas. Independent sets in triangle-free cubic planar graphs. *Journal of Combinatorial Theory, Series B*, 96(2):253–275, 2006.
- [7] S. C. Locke. Bipartite density and the independence ratio. *Journal of Graph Theory*, 10(1):47–53, 1986.
- [8] W. Staton. Some Ramsey-type numbers and the independence ratio. *Transactions of the American Mathematical Society*, 256:353–370, 1979.

The domination number of cylindrical graphs

José Juan Carreño ¹, José Antonio Martínez ^{2*} and María Luz Puertas ^{2*†}

¹ Technical University of Madrid, Spain

² Agrifood Campus of International Excellence (ceiA3), University of Almería, Spain

EXTENDED ABSTRACT

We present a lower bound for the domination number of the Cartesian product of a path and a cycle, that is tight if the length of the cycle is a multiple of five. This bound improves the natural lower bound obtained by using the domination number of the Cartesian product of two paths, that is the best one known so far.

Our strategy is similar to the approach in [5], where the concept of wasted domination in grids was introduced. We redefine this parameter in cylinders and moreover, we use a technique inspired by the construction of cylinders as rotagraphs [6, 7], to design a $(\min, +)$ matrix multiplication algorithm that computes the minimum wasted domination. These tools will allow us to obtain the new lower bound. The results presented here can be found in [3].

1 Known bounds

A *dominating set* in a graph G is a vertex subset S such that every vertex in $V(G) \setminus S$ has a neighbor in S . The *domination number* $\gamma(G)$ is the minimum size of a dominating set of G . The cylinder $P_m \square C_n$ is the Cartesian product of path P_m and cycle C_n and the exact value of $\gamma(P_m \square C_n)$ remains unknown for the general case. The known bounds of $\gamma(P_m \square C_n)$, for big enough $m \geq n$, are:

$$\left\lfloor \frac{(m+2)n}{5} \right\rfloor - 4 \leq \gamma(P_m \square C_n) \leq \begin{cases} (m+2)k & \text{if } n = 5k, \\ (m+2)(k + \frac{3}{8}) & \text{if } n = 5k + 1, \\ (m+2)(k + \frac{1}{2}) & \text{if } n = 5k + 2, \\ (m+2)(k+1) & \text{otherwise.} \end{cases}$$

The lower bound comes from the general formula for the domination number of grids [4]

$$\left\lfloor \frac{(m+2)n}{5} \right\rfloor - 4 = \gamma(P_m \square P_{n-2}) \leq \gamma(P_m \square C_n)$$

and the upper bound (see [7]), is not tight for $n \not\equiv 0 \pmod{5}$. However, the dominating set of $P_m \square C_{5k}$ with $(m+2)k$ vertices shown in [7] (see Figure 1), is likely to be optimal.

2 Wasted domination in cylinders

In order to improve the known lower bound, we recall the concept of wasted domination from [5]. A dominating set of $P_m \square C_n$ avoiding overlapping among the neighborhoods of its vertices, would have cardinal close to $mn/5$. But such dominating sets, also called perfect codes, just exist in cylinders with $m = 2$ and $n \equiv 0 \pmod{4}$ (see [1]). The wasted domination computes how far this $\gamma(P_m \square C_m)$ from $mn/5$.

Definition 1 (adapted from [5]) Let $A \subseteq V(P_m \square C_n)$. The *wasted domination* of A is $w(A) = 5|A| - |N[A]|$, where $N[A]$ is the closed neighborhood of A .

If S is a minimum dominating set of $P_m \square C_n$, then $\gamma(P_m \square C_n) = \frac{mn + w(S)}{5}$. In order to compute a lower bound for $w(S)$, we divide $P_m \square C_n$ ($m \geq 20$) into three cylinders G_1, G_2, G_3 (see Figure 2).

*Partially supported by grant RTI2018-095993-B-I00

†Partially supported by grant MTM2015-63791-R (MINECO/FEDER)

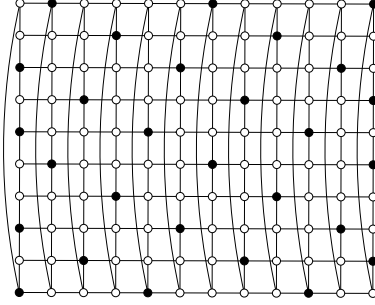

Figure 1: Dominating set of $P_{12} \square C_{10}$ with $\frac{(12+2)10}{5}$ vertices and following a regular pattern

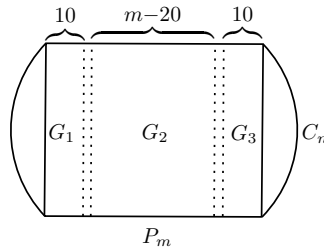

Figure 2: Partition of the cylinder $P_m \square C_n$

For D a dominating of $P_m \square C_n$, not necessarily minimum, we denote $D_k = D \cap V(G_k)$. Then

$$w(D) \geq w(D_1) + w(D_2) + w(D_3) \geq w(D_1) + w(D_3).$$

We expect the wasted domination to be mainly “located” next to both borders of the cylinder, while $w(D_2)$ is zero or close to zero. We compute a lower bound of $w(D_1)$ and $w(D_3)$ by applying the following theorem to an appropriate weighted digraph.

Theorem 2 (Carre’79 [2]) *Let G be a digraph with vertex set $V(G) = \{v_1, v_2, \dots, v_s\}$ together with a labeling function ℓ which assigns to every arc of G an element of the semi-ring of tropical numbers in the min convention $(\mathbb{R} \cup \{\infty\}, \min, +, \infty, 0)$ (see [8]). Let S_{ij}^k be the set of paths of length k from v_i to v_j and let $A(G)$ be the matrix defined by*

$$A(G)_{ij} = \begin{cases} \ell(v_i, v_j) & \text{if } (v_i, v_j) \text{ is an arc of } G, \\ \infty & \text{otherwise.} \end{cases}$$

Then $(A(G)^k)_{ij} = \min\{\ell(Q) : Q \in S_{ij}^k\}$ (using the $(\min, +)$ matrix power).

This result that was also used in [6, 7], but our choice of a suitable weighted digraph is inspired by the construction shown in [9], that also provides a technique to recursively compute a general formula for the minimum wasted domination, by using standard properties of the $(\min, +)$ matrix multiplication. We have obtained the following result.

Proposition 3 *For $P_m \square C_n$ with $m \geq 20, n \geq 30$ and for $i = 1, 3$:*

$$w(D_i) \geq L(n) = \begin{cases} n + 1 & \text{if } n = 32, 33, 37, 38, 42, 43, 47, 48, 53, 58, 63, \\ n & \text{otherwise.} \end{cases}$$

3 Main Results

We can now use the minimum value of wasted domination to find a lower bound for the domination number of the cylinder

Theorem 4 For $20 \leq m$, $30 \leq n$:

$$\gamma(P_m \square C_n) \geq \begin{cases} \left\lceil \frac{n(m+2)+2}{5} \right\rceil & \text{if } n = 32, 33, 37, 38, 42, 43, 47, 48, 53, 58, 63, \\ \left\lceil \frac{n(m+2)}{5} \right\rceil & \text{otherwise.} \end{cases}$$

The case $n \equiv 0 \pmod{5}$ has an special behaviour because the upper bound shown in [7], combined with this new lower bound, gives the exact value of the domination number.

Corollary 5 For $20 \leq m$ and $30 \leq n \equiv 0 \pmod{5}$:

$$\gamma(P_m \square C_n) = \frac{n(m+2)}{5}$$

References

- [1] R. Barbosa and P. Slater. On the efficiency index of a graph. **J. Comb. Optim.** 31:1134–1141, 2016.
- [2] B. Carré. Graphs and Networks. Clarendon Press, Oxford, (1979).
- [3] J.J. Carreño, J.A Martínez and M.L. Puertas. A General Lower Bound for the Domination Number of Cylindrical Graphs. **Bull. Malays. Math. Sci. Soc.** accepted
- [4] D. Gonçalves, A. Pinlou, M. Rao and S. Thomassé. The Domination Number of Grids. **SIAM J. Discrete Math.** 25:1443–1453, 2011.
- [5] D.R. Guichard. A lower bound for the domination number of complete grid graphs. **J. Combin. Math. Combin. Comput.** 49:215–220, 2004.
- [6] S. Klavžar and J. Žerovnik. Algebraic approach to fasciagraphs and rotagraphs. **Discrete Applied Mathematics** 68:93–100, 1996.
- [7] P. Pavlič and J. Žerovnik. A note on the domination number of the Cartesian products of paths and cycles. **Kragujevac J. Math.** 37:275–285, 2013.
- [8] J.-E. Pin. Tropical Semirings. **Publications of the Newton Institute** 11:50–69, 1998.
- [9] A. Spalding. Min-Plus Algebra and Graph Domination. (Ph.D. Thesis). Department of Applied Mathematics, University of Colorado, (1998).

On star edge colorings of bipartite and subcubic graphs

*Carl Johan Casselgren*¹, *Jonas Granholm*¹, and *André Raspaud*²

¹ Linköping University, Sweden

² LaBRI-CNRS, University of Bordeaux, France

EXTENDED ABSTRACT

A *star edge coloring* of a graph is a proper edge coloring with no 2-colored path or cycle of length four. The *star chromatic index* $\chi'_{st}(G)$ of G is the minimum number t for which G has a star edge coloring with t colors.

Star edge coloring was recently introduced by Liu and Deng [5], motivated by the vertex coloring version, see e.g. [1, 4]. This notion is intermediate between *acyclic edge coloring*, where every two-colored subgraph must be acyclic, and *strong edge coloring*, where every color class is an induced matching.

Dvorak et al [3] studied star edge colorings of complete graphs and obtained the currently best upper and lower bounds for the star chromatic index of such graphs. A fundamental open question here is to determine whether $\chi'_{st}(K_n)$ is linear in n . Bezegova et al [2] investigated star edge colorings of trees and outerplanar graphs. Wang et al. [8, 9] quite recently obtained some upper bounds on the star chromatic index of graphs with maximum degree four, and also for some families of planar and related classes of graphs. Besides these results, very little is known about star edge colorings.

We primarily consider star edge colorings of bipartite graphs. As for complete graphs, a fundamental problem for complete bipartite graphs is to determine whether the star chromatic index is a linear function on the number of vertices. We determine the star chromatic index of complete bipartite graphs where one part has size at most 3, and obtain some bounds on the star chromatic index for larger complete bipartite graphs.

Furthermore, we study star edge colorings of bipartite graphs where the vertices in one part all have small degrees. Nakprasit [7] proved that if G is a bipartite graph where the maximum degree of one part is 2, then G has a strong edge coloring with $2\Delta(G)$ colors; we prove analogous results for star edge colorings.

Theorem 1 *If G is a bipartite graph where the parts have maximum degree 2 and $2k$, respectively, then $\chi'(G) \leq 3k$.*

The upper bound in Theorem 1 is sharp. Using Theorem 1 we deduce the following upper bound which is best possible up to a additive factor of 1.

Corollary 2 *If G is a bipartite graph where the parts have maximum degree 2 and $2k+1 \geq 3$, respectively, then $\chi'_{st}(G) \leq 3k+3$.*

Finally, we consider the following conjecture first posed in [3].

Conjecture 3 *If G has maximum degree at most 3, then $\chi'_{st}(G) \leq 6$.*

Dvorak et al [3] proved a slightly weaker version of Conjecture 3, namely that $\chi'_{st}(G) \leq 7$ if G is cubic; Bezegova et al [2] established that Conjecture 3 holds for all trees and outerplanar graphs; while the conjecture is still open for e.g. planar graphs. We verify that the conjecture holds for some families of graphs, namely bipartite graphs where one part has maximum degree 2, cubic Halin graphs and another family of planar graphs.

References

- [1] M. O. Albertson, G. G. Chappell, H. A. Kierstead, A. Kündgen, and R. Ramamurthi, Coloring with no 2-colored P_4 's, *Electron J Combin* 11 (2004), R26.
- [2] L. Bezegova, B. Luzar, M. Mockovciakova, R. Sotak, R. Skrekovski, Star edge coloring of some families of graphs, *Journal of Graph Theory* 81 (2016), 73–82
- [3] Z. Dvorak, B. Mohar, R. Samal, Star chromatic index, *Journal of Graph Theory* 72 (2013), 313–326.
- [4] G. Fertin, A. Raspaud, and B. Reed, Star coloring of graphs, *J Graph Theory* 47 (2004), 163–182.
- [5] X.-S- Liu, K. Deng, An upper bound on the star chromatic index of graphs with $\Delta \geq 7$, *J. Lanzhou Univ. (Nat. Sci.)* 44 (2008), 94–95.
- [6] B. Luzar, Martina Mockovciakova, Roman Sotak, Note on list star edge coloring of sub-cubic graphs, *Journal of Graph Theory* 90 (2019), 304–310.
- [7] K. Nakprasit, A note on the strong chromatic index of bipartite graphs, *Discrete Mathematics* 308 (2008), 3726–3728.
- [8] Y. Wang, Y. Wang, W. Wang, Star edge-coloring of graphs with maximum degree four, *Applied Mathematics and Computation* 340 (2019), 268–275.
- [9] Y. Wang, Y. Wang, W. Wang, Edge-partition and star chromatic index *Applied Mathematics and Computation* 333 (2018), 480–489.

A note on $(3, 1)$ -choosability of planar graphs

Carl Johan Casselgren ¹, Jonas Granholm ¹, and André Raspaud ²

¹ Linköping university, Sweden

² LaBRI-CNRS, University of Bordeaux, France

EXTENDED ABSTRACT

Given a graph G , assign to each vertex v of G a set $L(v)$ of colors (positive integers). Such an assignment L is called a *list assignment* for G and the sets $L(v)$ are referred to as *lists* or *color lists*. We then want to find a proper vertex coloring φ of G , such that $\varphi(v) \in L(v)$ for all $v \in V(G)$. If such a coloring φ exists then G is *L -colorable* and φ is called an *L -coloring*. Furthermore, G is called *k -choosable* if it is *L -colorable* for every *k -list assignment* L . This particular variant of vertex coloring is known as *list coloring* or *choosability* of graphs and was introduced independently by Vizing [8] and by Erdős et al. [4].

A recent variation on list coloring is the so-called model of choosability with separation, where we require that lists of adjacent vertices have a bounded number of common colors. A *(k, d) -list assignment* for a graph G is a map that assigns to each vertex v a list $L(v)$ of at least k colors such that $|L(x) \cap L(y)| \leq d$ whenever x and y are adjacent. A graph is *(k, d) -choosable* if for every *(k, d) -list assignment* L of G there is an *L -coloring* of G .

Choosability with separation was first considered by Kratochvíl et al. [5]. Among other things, they proved that every planar graph is $(4, 1)$ -choosable, which is a refinement for choosability of separation of Thomassens well-known result that planar graphs are 5-choosable [7].

Skrekovski [6] gave examples of triangle-free planar graphs that are not $(3, 2)$ -choosable, and posed the following question:

Problem 1 *Is every planar graph $(3, 1)$ -choosable?*

It follows from a result of Kratochvíl et al. [5] that this question has a positive answer for the case of triangle-free graphs. Recently, Choi et al. [3] proved that planar graphs without 4-cycles are $(3, 1)$ -choosable, and Chen et al. [2] improved this slightly by proving that planar graphs with no adjacent 4-cycles and no adjacent 3- and 4-cycles are $(3, 1)$ -choosable, where two cycles of a graph are *adjacent* if they share a common edge; two cycles are *intersecting* if they have at least one common vertex.

The main purpose of this talk is to give some further progress on Problem 1. In particular we prove the following:

Theorem 2 *If G is a planar graph with no intersecting triangles and no intersecting 4-cycles, then G is $(3, 1)$ -choosable.*

Theorem 3 *If G is a planar graph where every triangle has most one edge in common with a 4-cycle and every 5-, 6-, and 7-cycle has at most two, four, and six edges, respectively, in common with triangles, then G is $(3, 1)$ -choosable.*

Theorem 4 *If G is a planar graph where no triangle of G is adjacent to a triangle or a 4-cycle, and each 5-cycle has at most three edges in common with triangles, then G is $(3, 1)$ -choosable.*

The proofs of these results are based on connections between $(3, 1)$ -choosability and orientations of the underlying graph, which makes them rather short compared to the proofs of many other results in this area (cf. [3, 1, 2]).

References

- [1] M. Chen, Y. Fan, Y. Wang, and W. Wang. A sufficient condition for planar graphs to be $(3, 1)$ -choosable. *Journal of Combinatorial Optimization*, 34(4):987–1011, 2017.
- [2] M. Chen, K.-W. Lih, and W. Wang. On choosability with separation of planar graphs without adjacent short cycles. *Bulletin of the Malaysian Mathematical Sciences Society*, 41(3):1507–1518, 2018.
- [3] I. Choi, B. Lidický, and D. Stolee. On choosability with separation of planar graphs with forbidden cycles. *Journal of Graph Theory*, 81(3):283–306, 2016.
- [4] P. Erdős, A. L. Rubin, and H. Taylor. Choosability in graphs. *Proc. West Coast Conf. on Combinatorics, Graph Theory and Computing, Congressus Numerantium*, XXVI:125–157, 1979.
- [5] J. Kratochvíl, Z. Tuza, and M. Voigt. Brooks-type theorems for choosability with separation. *Journal of Graph Theory*, 27(1):43–49, 1998.
- [6] R. Skrekovski. A note on choosability with separation for planar graphs. *Ars Combinatoria*, 58:169–174, 2001.
- [7] C. Thomassen. 3-list-coloring planar graphs of girth 5. *Journal of Combinatorial Theory, Series B*, 64(1):101 – 107, 1995.
- [8] V. G. Vizing. Coloring the vertices of a graph with prescribed colors. *Metody Diskretnogo Analiza Teorii Kodov i Skhem*, 29:3–10, 1976. In Russian.

Kernelization of Graph Hamiltonicity: Proper H -Graphs

Steven Chaplick¹, Fedor Fomin², Petr Golovach², Dušan Knop³, and Peter Zeman⁴

¹ Lehrstuhl für Informatik I, University of Würzburg, Würzburg, Germany

² Department of Informatics, University of Bergen, Bergen, Norway

³ Department of Theoretical Computer Science, Czech Technical University in Prague, Prague, Czech Republic

⁴ Department of Applied Mathematics, Charles University, Prague, Czech Republic

EXTENDED ABSTRACT

HAMILTONIAN CYCLE is one of the oldest mathematical puzzles, whose study can be traced back to the 9th century, and it is still actively studied. Our results about the HAMILTONIAN CYCLE problem are in the intersection of two research areas: kernelization and algorithms on special graph classes. In both areas HAMILTONIAN CYCLE has been intensively investigated. **Graph classes.** There is a large research area in graph algorithms, where the structural properties of graphs, like being interval or chordal, are exploited for developing of efficient algorithms problems intractable on general graphs. We refer to the book [4] for the introduction and survey of the known results. Without a doubt, the oldest and the most studied class of intersection graphs is the class of interval graphs and there is a long history of research on the HAMILTONIAN CYCLE and HAMILTONIAN PATH problems on interval, circular-arc and related graph classes. It was shown by Keil [10] in 1985 that HAMILTONIAN CYCLE can be solved in linear time for interval graphs (see also [5, 7]). The problem for circular-arc graphs proved to be much more involved and the first polynomial algorithm for HAMILTONIAN CYCLE on circular-arc graphs was given by Shih et al. [14] in 1992. On the other hand, for proper interval graphs, it was already shown by Bertossi [1] that every connected proper interval graph has a Hamiltonian path, and a proper interval graph has a Hamiltonian cycle if and only if it is 2-connected graph with at least three vertices. HAMILTONIAN CYCLE can be solved in linear time for (proper) interval and circular graphs (see [3]). For chordal graphs, HAMILTONIAN CYCLE is well-known to be NP-complete and is even NP-complete for strongly chordal split graphs [12].

Our results. In this paper we follow the main question of structural kernelization—if a computational problem can be solved in polynomial time on instances with some structural properties, does it admit a polynomial kernel parameterized by some distance to this structural property? In our setting the structural property is to be a proper interval graph. However, the distance we use is quite different from the commonly used the size of a modulator.

Our measure of similarity with proper interval graphs is based on the beautiful concept of H -graph introduced by Biró et al. [2] in the context of the precoloring extension problem. An *intersection representation* of a graph G assigns a set S_v to every vertex $v \in V(G)$ such that $S_u \cap S_v \neq \emptyset$ if and only if $uv \in E(G)$. When the sets S_u are intervals of the real line, this defines an interval graph. From a different perspective, every interval graph can be viewed as an intersection graph of subpaths of some (sufficiently long) path. Similarly, *circular-arc graphs*, a natural generalization of interval graphs, are the intersection graphs of subpaths of some cycle. It is also a well-known fact that a graph is *chordal* if and only if it is an intersection graph of subtrees of some tree. All of these classes are known to have efficient algorithms for various computational problems. We refer to [4] for the introduction and survey of the known results. A natural generalization of these classes are intersection graphs of subgraphs of some subdivision of an arbitrary *underlying graph* H . For a fixed graph H , we say that a graph G is an H -graph, if it is an intersection graph of connected subgraphs of a subdivision of H . In this language, interval graphs are K_2 -graphs, circular-arc graphs are K_3 -graphs, and every chordal graph is a T -graph for some tree T .

An *intersection representation* $\{S_v\}_{v \in V(G)}$ of a graph G is a *proper* representation, if $S_u \subseteq S_v$ implies $u = v$. Then a graph G is a *proper H -graph*, if it admits a proper intersection representation by connected subgraphs of a subdivision of H . For example, proper K_2 -graphs

are proper interval graphs, that is, the graphs admitting a proper representation by intervals of the real line. Various aspects of proper interval and proper circular-arc representations are well-studied, and our goal is again to study how these carry to general proper H -graphs. Clearly, all positive algorithmic results obtained for H -graphs e.g. in [6, 8] are valid for proper H -graphs, but since we consider a more restricted graph class, we can hope that the tractability area could be expanded.

Note that every graph has the following trivial model (representation). For a graph G , let $I(G)$ be the *incidence* graph of G , that is, the result of subdividing each edge of G exactly once. Then, the graph G is a proper G -graph: Its trivial proper G -representation is $(I(G), \{N_{I(G)}[v]\}_{v \in V(G)})$.

We consider the following fundamental generalizations of HAMILTONIAN CYCLE and HAMILTONIAN PATH problems.

CYCLE COVER (PATH COVER)
 Input: A graph G and a positive integer k .
 Task: Decide whether G has a cycle (path) cover \mathcal{C} with at most k cycles (paths).

The main results of this paper are the following theorems about kernelization of CYCLE COVER and PATH COVER. In both theorems we assume that a proper H -representation of input graph G is given.

Theorem 1 PATH COVER admits a kernel of size $\mathcal{O}(h^8)$, where h is the size of the graph H in a proper H -representation of the input graph G .

For CYCLE COVER we only construct a polynomial compression of the explicitly stated size. (Roughly speaking, the difference between kernelization and compression is that kernelization algorithm outputs an equivalent instance of the same parameterized problem, while a compression algorithm maps an instance of a parameterized problem to an equivalent instance of another non-parameterized problem; see e.g. [9] for more details.)

Theorem 2 CYCLE COVER admits a compression of size $\mathcal{O}(h^{10})$, where h is the size of the graph H in a proper H -representation of the input graph G .

It is worth noting that for the special case of CYCLE COVER with $k = 1$, namely HAMILTONIAN CYCLE, we also are able to obtain a kernel of size $\mathcal{O}(h^8)$.

Note that, the requirement that a proper H -representation is given in the input of the considered problems on proper H -graphs is likely unavoidable. Namely, the hardness result of Chaplick et al. [6] can be adapted to show that the recognition problem for proper H -graphs is NP-hard even for small fixed graphs H .

From small Clique Covers to Kernels. The parameterization of HAMILTONIAN CYCLE by the clique cover size was considered by Lampis et al. [11] who proved that the problem is FPT for this parameterization. We extend their result by showing the following theorem.

Theorem 3 CYCLE COVER, PATH COVER, and HAMILTONIAN CYCLE admit kernels of size $\mathcal{O}(s^8)$, where s is the size of a clique cover.

Here we only sketch the main ideas of the kernelization for CYCLE COVER, which is the easiest among these problems.

Recall that a clique cover is a collection $\mathcal{Q} = \{Q_1, \dots, Q_s\}$ of disjoint cliques such that $V(G) = \bigcup_{i=1}^s Q_i$. First we show that there is always an optimal solution to CYCLE COVER with very specific properties. We call a cycle cover *regular* (for the clique cover $\mathcal{Q} = \{Q_1, \dots, Q_s\}$) if it satisfies the following properties for each distinct $i, j \in \{1, \dots, s\}$:

- (i) at most one cycle of the cover has an edge between cliques Q_i and Q_j ,
- (ii) every cycle of the cover has at most two edges between Q_i and Q_j .

It is possible to prove that every cycle cover can be transformed into a regular one without increasing its size. Informally, if two distinct cycles have edges between two cliques Q_i and Q_j , we can “glue” them together as it is shown in Figure 1(left), and if a cycle has at least three edges between the cliques, then we can pick two of them that are in the “same direction” according an arbitrary orientation of the cycle and reroute the cycle, see Figure 1(right).

Because the cycles of a regular cycle cover have a limited number of edges that are between the cliques of \mathcal{Q} , it is possible to modify and/or reroute them using the fact that the vertices of the same clique are pairwise adjacent. The regularity of a cycle cover allows us to apply the following reduction rules.

- If there is a clique $Q_i \in \mathcal{Q}$ and $v \in Q_i$ such that $N_G[v] = Q_i$ and $|Q_i| \geq s + 3$, then set $G = G - v$ and $Q_i = Q_i \setminus \{v\}$.
- If there are $i, j \in \{1, \dots, s\}$, $i \neq j$, such that the bipartite graph G_{ij} , with vertex set $Q_i \cup Q_j$ and whose edges are the edges of G between Q_i and Q_j , has a matching M of size at least $4s - 3$, then select (arbitrarily) an edge $e \in M$, set $G = G - e$.
- If there is a clique $Q_i \in \mathcal{Q}$ and $v \in V(G) \setminus Q_i$ such that $|N_G(v) \cap Q_i| \geq 2s + 1$, then for an arbitrary edge $e = uv$ with $u \in Q_i$, set $G = G - e$.

We apply the rules exhaustively. It is not hard to see that in none of the above rules is applicable to a graph G , then G has $\mathcal{O}(s^4)$ vertices, that is, the size of the obtained instance of CYCLE COVER is $\mathcal{O}(s^8)$ and this implies the claim of Theorem 3 for the problem.

From Proper H -representations to Small Clique Covers. Now we use Theorem 3 to construct kernelization and compression algorithms for PATH COVER and CYCLE COVER on proper H -graphs, i.e., we build kernels with small clique covers.

Suppose that G is a proper H -graph given together with its proper H -representation (H', \mathcal{M}) . Notice that for every branching node $x \in V(H)$, the set $K_x = \{v \in V(G) \mid x \in M_v\}$ is a clique of G , where M_v is the model of the vertex v (i.e., a connected component of a subdivision of H). Observe also that the graph $G - \bigcup_{x \in V(H)} K_x$ can be seen as a union of proper interval graphs G_e corresponding to the edges $e \in E(H)$. More formally, let $e = xy \in E(H)$ and consider the (x, y) -path P_e in H' obtained from e by the subdivisions. We denote by G_e the subgraph of G induced by $V_e = \{v \in V(G) \mid M_v \subseteq V(P_e) \setminus \{x, y\}\}$. Clearly, G_e is a proper interval graph and the sets M_v for $v \in V_e$ form a proper interval representation of it. This representation defines a corresponding total ordering of its vertices (see [13]). We assume that these orderings are fixed for every G_e . In particular, whenever we speak about leftmost and rightmost vertices of G_e , we mean the leftmost and the rightmost vertices with respect to this ordering. Notice that for $e = xy$, $N_G(V_e) \subseteq K_x \cup K_y$, that is, paths or cycles that cover the vertices in G_e are either completely in G_e or enter G_e via the vertices of K_x or K_y that we call the *left* and *right* cliques respectively.

The graphs G_e could be huge but, since they are proper interval graphs, they have a relatively simple structure. We exploit this structure in order to replace them by small gadget graphs while maintaining the equivalence of the instances of the considered problems.

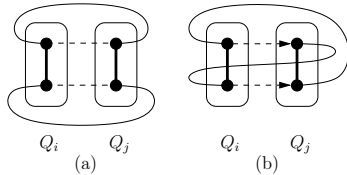

Figure 1: Rerouting cycles; the deleted edges are shown by dashed lines and the added edges are shown by thick lines.

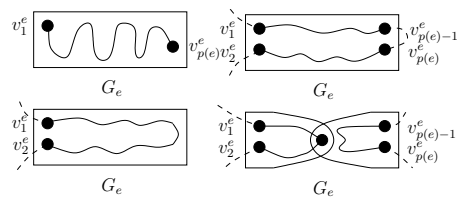

Figure 2: The types of covering (up to symmetry) of G_e by a tamed path cover.

Since the vertices of $\bigcup_{x \in V(H)} K_x$ can be covered by at most $|V(H)|$ cliques and the set of vertices of each gadget replacing G_e can be covered by a constant number of cliques, we obtain a graph that has a clique cover of size $\mathcal{O}(|V(H)| + |E(H)|)$.

Covering G_e . Without loss of generality we assume G_e is connected. One possibility is that \mathcal{P}_e (the path cover of G_e) consists of a single Hamiltonian path of G_e with its end-vertices being the leftmost and the rightmost vertices of G_e . In all other cases, \mathcal{P}_e consists of at most two paths that are proper subpaths of some paths of \mathcal{P} and, moreover, every path of \mathcal{P}_e extends in two directions in the path of \mathcal{P} .

The structure of paths in the projection of a path cover is shown in Figure 2, the vertices of G_e are denoted by $v_1^e, \dots, v_{p(e)}^e$ in the figure according to their proper interval ordering. Note that every path of the path cover \mathcal{P} that enters G_e uses the (one or two) leftmost and rightmost vertices as entry-points.

References

- [1] Bertossi, A.A.: Finding Hamiltonian circuits in proper interval graphs. *Inf. Process. Lett.* **17**(2), 97–101 (1983).
- [2] Biro, M., Hujter, M., Tuza, Z.: Precoloring extension. I. Interval graphs. *Discrete Mathematics* **100**(1), 267–279 (1992).
- [3] Brandstädt, A., Dragan, F.F., Köhler, E.: Linear time algorithms for hamiltonian problems on (claw, net)-free graphs. *SIAM J. Comput.* **30**(5), 1662–1677 (2000).
- [4] Brandstädt, A., Le, V.B., Spinrad, J.P.: Graph classes: a survey. *SIAM Monographs on Discrete Mathematics and Applications*, SIAM, Philadelphia, PA (1999).
- [5] Broersma, H., Fiala, J., Golovach, P.A., Kaiser, T., Paulusma, D., Proskurowski, A.: Linear-time algorithms for scattering number and hamilton-connectivity of interval graphs. *Journal of Graph Theory* **79**, 282–299, (2015).
- [6] Chaplick, S., Toepfer, M., Voborník, J., Zeman, P.: On H-topological intersection graphs. In: *WG. LNCS*, vol. 10520, pp. 167–179. Springer (2017).
- [7] Damaschke, P.: Paths in interval graphs and circular arc graphs. *Discrete Mathematics* **112**(1-3), 49–64 (1993).
- [8] Fomin, F. V., Golovach, P. A., and Raymond, J.: On the tractability of optimization problems on H-graphs, in *ESA 2018*, vol. 112 of *LIPICs*, Schloss Dagstuhl - Leibniz-Zentrum fuer Informatik, pp. 30:1–30:14 (2018).
- [9] Fomin, F.V., Lokshtanov, D., Saurabh, S., Zehavi, M.: *Kernelization. Theory of Parameterized Preprocessing*. Cambridge University Press (2019).
- [10] Keil, J.M.: Finding hamiltonian circuits in interval graphs. *Inf. Process. Lett.* **20**(4), 201–206 (1985).
- [11] Lampis, M., Makino, K., Mitsou, V., Uno, Y.: Parameterized edge hamiltonicity. *Discrete Appl. Math.* **248**, 68–78 (2018).
- [12] Müller, H.: Hamiltonian circuits in chordal bipartite graphs. *Discrete Mathematics* **156**(1-3), 291–298 (1996).
- [13] Roberts, F.S.: Indifference graphs. In: *Proof Techniques in Graph Theory (Proc. Second Ann Arbor Graph Theory Conf., 1968)*, pp. 139–146. Academic Press, New York (1969).
- [14] Shih, W., Chern, T.C., Hsu, W.: An $o(n^2 \log n)$ algorithm for the hamiltonian cycle problem on circular-arc graphs. *SIAM J. Comput.* **21**(6), 1026–1046 (1992).

Two-dimensional partial cubes

Victor Chepoi, Kolja Knauer, and Manon Philibert

LIS, Aix-Marseille Université, France
CNRS, Marseille, France

EXTENDED ABSTRACT

We investigate the structure of two-dimensional partial cubes, i.e., of isometric subgraphs of hypercubes whose vertex set defines a set family of VC-dimension at most 2. To establish an isometric embedding of a graph G into a hypercube, Djoković [6] introduced a binary relation Θ – called *Djoković-Winkler relation* – on the edges of G . It can be shown that Θ is an equivalence relation which defines classes of parallel edges. Therefore, two-dimensional partial cubes are partial cubes which are not contractible to the 3-cube Q_3 . Here contraction means contracting the edges belonging to the same class of parallel edges, i.e. edges corresponding to the same coordinate of the hypercube. We establish a multitude of properties of those partial cubes. We show that any two-dimensional partial cube can be built from specific combinatorial cells and can be completed to a two-dimensional ample graph.

Partial cubes comprise many important and complex graph classes occurring in metric graph theory and initially arising in completely different areas of research such as geometric group theory, combinatorics, discrete geometry, and media theory. Most of those classes can be characterized via forbidden Q -minors; in case of partial cubes, Q -minors are endowed with a second operation called *restriction* and are called *partial cube minors*, or *pc-minors* [4]. The class of partial cubes is closed under pc-minors. Thus, given a set G_1, G_2, \dots, G_n of partial cubes, one considers the set $\mathcal{F}(G_1, \dots, G_n)$ of all partial cubes not having any of G_1, G_2, \dots, G_n as a pc-minor. For example, the following classes can be characterized via forbidden Q -minors: hypercellular graphs ($\mathcal{F}(Q_3^-)$ [4]), median graphs ($\mathcal{F}(Q_3^-, C_6)$ [4]), bipartite cellular graphs ($\mathcal{F}(Q_3^-, Q_3)$ [4]), rank two of complexes of oriented matroids (COMs) ($\mathcal{F}(SK_4, Q_3)$ [10]), and two-dimensional ample graphs ($\mathcal{F}(C_6, Q_3)$ [10]). Here Q_3^- denotes the 3-cube Q_3 with one vertex removed and SK_4 the full subdivision of K_4 .

Moreover, partial cubes can be viewed as set families which are fundamental objects in combinatorics, algorithmics, machine learning, discrete geometry, and combinatorial optimization. The Vapnik-Chervonenkis dimension of a set family $\mathcal{S} \subseteq 2^X$ is the size of a largest subset of $Y \subseteq X$ which can be *shattered* by \mathcal{S} [15], i.e., $2^Y = \{Y \cap S : S \in \mathcal{S}\}$. Introduced in statistical learning by Vapnik and Chervonenkis [15], the VC-dimension was adopted in the above areas as complexity measure and as a combinatorial dimension of \mathcal{S} . An important inequality relates a set family $\mathcal{S} \subseteq 2^X$ with its VC-dimension, called the *sandwich lemma*, proves that $|\mathcal{S}|$ is sandwiched between the number of strongly shattered sets and the number of shattered sets [1, 3, 7, 14]. The set families for which the upper bounds in the sandwich lemma are tight are called *ample* or *lopsided* [2, 3, 11].

We can easily show the next result that points out the link between classes of partial cubes having cube-free pc-minors and their VC-dimension.

Lemma 1 *A partial cube G belongs to $\mathcal{F}(Q_{d+1})$ if and only if G has VC-dimension $\leq d$.*

We consider the class $\mathcal{F}(Q_3)$, i.e. the class of partial cubes which has no 3-cube as pc-minors. By Lemma 1, they correspond to partial cubes of VC-dimension at most 2. We called them *two-dimensional partial cubes*.

Now we want to understand the structure of those graphs. Let us introduce the notion of gatedness before to describe the combinatorial cells. A subgraph H of G induced by V is called *gated* in G [8] if for every vertex x outside H there exists a vertex x' , the *gate* of x , in H such that each vertex y of H is connected with x by a shortest path passing through

the gate x' . We can show that the gate of x is unique and that gated sets are convex. Since the intersection of gated subgraphs is gated, for every subset $S \subseteq V$ there exists the smallest gated set $\text{gate}(S)$ containing S , referred to as the *gated hull* of S .

We say that a graph is a *full subdivision of K_n* (or *full subdivision* for short) if it is the graph obtained from the complete graph K_n on n vertices by subdividing each edge of K_n once. We show that any two-dimensional partial cube can be obtained by amalgamations from two types of combinatorial cells : gated cycles and gated full subdivisions, see Figure 1.

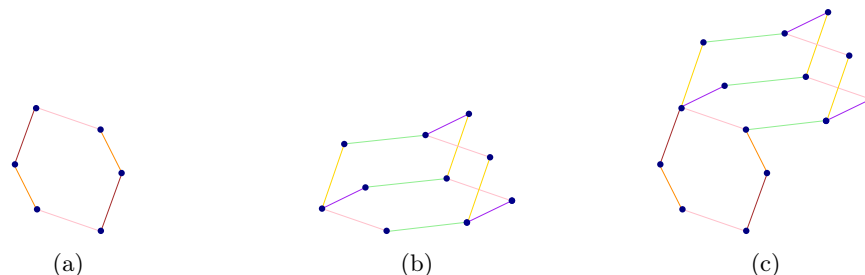

Figure 1: (a) A gated cycle. (b) A gated full subdivision. (c) Amalgamation of (a) and (b).

Then, we explore the gated hull of isometric cycles. We say that a partial cube is a disk if it is the region graph of a pseudoline arrangement. We show the following result:

Theorem 2 *Let G be a two-dimensional partial cube. Then the gated hull of each isometric cycle C of G is a disk or a full subdivision.*

The cell structure of two-dimensional partial cubes enables us to establish a variety of results. The main property of two-dimensional partial cubes that we showed is :

Theorem 3 *Any $G \in \mathcal{F}(Q_3)$ can be completed to an ample partial cube $(G^\nabla)^\Gamma \in \mathcal{F}(Q_3)$.*

We perform this completion in two steps. First, we canonically extend G to a partial cube $G^\nabla \in \mathcal{F}(Q_3)$ not containing convex full subdivisions. The resulting graph G^∇ is a COM of rank 2: its cells are the gated cycles of G and the 4-cycles created by extensions of full subdivisions. Second, we transform G^∇ into an ample partial cube $(G^\nabla)^\Gamma \in \mathcal{F}(Q_3)$ by filling each gated cycle C of length ≥ 6 of G (and of G^∇) by a planar tiling with squares.

This completion result yields that the set families defined by such graphs satisfy the sample compression conjecture by Littlestone and Warmuth [12] in a strong sense. They introduced this compression technique for deriving generalization bounds in machine learning. Floyd and Warmuth [9] asked whether any set family \mathcal{S} of VC-dimension d has a sample compression scheme of size $O(d)$. This question remains one of the oldest open problems in this area, that is far from being solved even for general set families of VC-dimension 2. In view of this, it was noticed in [13] that the original sample compression conjecture of [9] would be solved if *one can show that any set family \mathcal{S} of VC-dimension d can be extended to an ample partial cube of VC-dimension $O(d)$ or can be covered by $\exp(d)$ ample partial cubes of VC-dimension $O(d)$* . Considering this and Theorem 3, we obtain the following result:

Corollary 4 *Any set family which defines a two-dimensional partial cube admits a compression scheme of constant size, i.e. verify the sample compression conjecture of Littlestone and Warmuth.*

Additionally, we provide several characterizations of two-dimensional partial cubes; their proof and other characterizations can be found in the full version [5]. First, let us introduce some definitions. Let G be a partial cube and E_i be a Θ -class of G . The *hyperplane H_i* of E_i has the middles of edges of E_i as the vertex-set and two such middles are adjacent in H_i

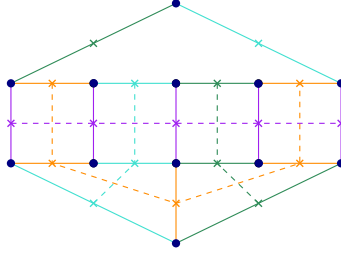

Figure 2: Hyperplanes of G

if and only if the corresponding edges belong to a common square of G . In the Figure 2, hyperplanes of G are represented with dotted lines.

Let G be a graph containing two isometric subgraphs G^1 and G^2 such that $G = G^1 \cup G^2$, there are no edges from $G^1 \setminus G^2$ to $G^2 \setminus G^1$, and $G^0 := G^1 \cap G^2$ is nonempty. Then the triple (G^1, G^0, G^2) is called an *isometric cover* of G . A graph G' is an *isometric expansion* of G with respect to an isometric cover (G^1, G^0, G^2) of G if G' is obtained from G by replacing each vertex v of G^1 by a vertex v_1 and each vertex v of G^2 by a vertex v_2 such that u_i and v_i , $i = 1, 2$ are adjacent in G' if and only if u and v are adjacent vertices of G^i and $v_1 v_2$ is an edge of G' if and only if v is a vertex of G^0 . For a construction of an isometric expansion of a partial cube G , we can see the Figure 3.

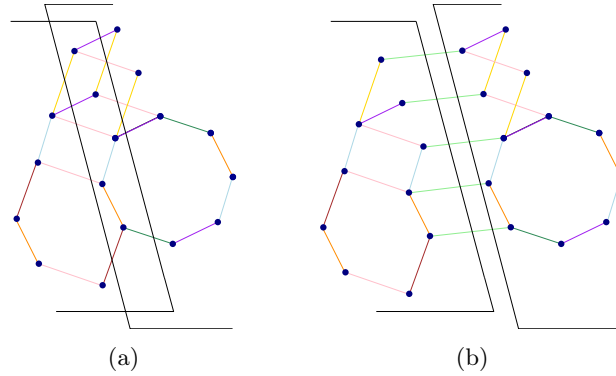

Figure 3: (a) A two-dimensional partial cube G . (b) An isometric expansion of G .

Theorem 5 For a partial cube $G = (V, E)$ the following conditions are equivalent:

- (i) G is a two-dimensional partial cube;
- (ii) the hyperplanes of G has VC-dimension ≤ 1 ;
- (iii) G can be obtained from the one-vertex graph via a sequence $\{(G_i^1, G_i^0, G_i^2) : i = 1, \dots, m\}$ of isometric expansions, where each $G_i^0, i = 1, \dots, m$ has VC-dimension ≤ 1 .

Moreover, any two-dimensional partial cube G satisfies the following condition:

- (iv) the gated hull of each isometric cycle of G is a disk or a full subdivision.

Note that it is not true that if in a partial cube G the convex hull of every isometric cycle is a two-dimensional partial cube, then G is too, see the graph H in Figure 4. However, we conjecture that the condition (iv) of Theorem 5 is equivalent to the other conditions:

Conjecture 6 Any partial cube G in which the gated hull of each isometric cycle is a disk or a full subdivision is a two-dimensional partial cube.

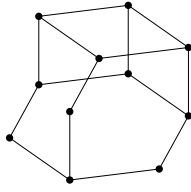

Figure 4: Graph H

References

- [1] R.P. Anstee, L. Rónyai, and A. Sali. Shattering news. In **Graphs and Combin.**, 18:59–73, 2002.
- [2] H.-J. Bandelt, V. Chepoi, A. Dress, and J. Koolen. Combinatorics of lopsided sets. In **Europ. J. Combin.**, 27:669–689, 2006.
- [3] B. Bollobás and A.J. Radcliffe. Defect Sauer results. In **J. Comb. Th. Ser. A**, 72:189–208, 1995.
- [4] V. Chepoi, K. Knauer, and T. Marc. Partial cubes without Q_3^- minors. **arXiv:1606.02154**.
- [5] V. Chepoi, K. Knauer and M. Philibert. Two-dimensional partial cubes. **arXiv:1906.04492**.
- [6] D.Ž. Djoković. Distance-preserving subgraphs of hypercubes. In **J. Combin. Th. Ser. B** 14:263–267, 1973.
- [7] A.W.M. Dress. Towards a theory of holistic clustering. In **DIMACS Ser. Discr. math. Theoret. Comput.Sci.**, 37:271–289, 1997.
- [8] A. W. M. Dress and R. Scharlau. Gated sets in metric spaces. In **Aequationes Math.** 34:112–120, 1987.
- [9] S. Floyd and M.K. Warmuth. Sample compression, learnability, and the Vapnik-Chervonenkis dimension. In **Machine Learning**, 21:269–304, 1995.
- [10] K. Knauer and M. Tilen. On tope graphs of complexes of oriented matroids. **arXiv:1701.05525**.
- [11] J. Lawrence. Lopsided sets and orthant-intersection of convex sets. In **Pacific J. Math.** 104:155–173, 1983.
- [12] N. Littlestone and M. Warmuth. Relating data compression and learnability. Unpublished, 1986.
- [13] S. Moran and M. K. Warmuth. Labeled compression schemes for extremal classes. In **ALT**, 34–49, 2016.
- [14] A. Pajor. Sous-espaces ℓ_1^n des espaces de Banach. Travaux en Cours, Hermann, Paris, 1985.
- [15] V.N. Vapnik and A.Y. Chervonenkis. On the uniform convergence of relative frequencies of events to their probabilities. In **Theory Probab. Appl.**, 16:264–280, 1971.

Graph Centralities and Cascading Failures in Networks

Francesc Comellas and *Llorenç Sánchez*

Department of Mathematics, Universitat Politècnica de Catalunya,
Esteve Terrades 5, 08750 Castelldefels (Barcelona) Catalonia, Spain

EXTENDED ABSTRACT

Cascading failures. A cascading failure in a complex system is a process in which an initial failure in one or several of its elements leads to a sequence of failures which spread to other elements and in some cases collapses the whole system.

In our interconnected world, these processes are increasingly becoming common and affect our everyday lives. This is the case of the recent power-grid failure of 16 June 2019 in Argentina and neighbor countries and the recurrent failures of Twitter, Facebook, Instagram and other social networks, all of them carrying important disruptions in relevant services.

What causes these cascade processes is not well understood, and thus they are really difficult to predict or contain. In many cases cascading failures arise from changes in flows, as happens in transportation networks, including electric grids or logistic supply chains, but there are not many models or a general graph theoretical framework to help in their analysis.

Background. The publication of a paper by Wang and Rong (WR) in 2009 [12] on cascading failures in the power grid of western US and Canada had a big impact. Their study was based on public data available from the most-cited paper on small-world networks by Watts and Strogatz [13] and received a wide interest after its review in the New York Times, with some curious anecdotes, like that a military analyst, L. M. Wortzel, asked the House of Foreign Affairs Committee to investigate the authors of the article for possible terrorism.

The WR paper had an important repercussion leading to tens of publications on this topic, including the study of other networked systems, interdependent networks, vulnerable sets, etc. (see, for example, [2, 11, 14, 10] and references therein.) This research is based mainly on computer simulations and in many cases lacks a founding mathematical background.

Since 1998 [13] we know that many graphs which are associated to complex systems belong, mainly, to a category that is now known as "small-world scale-free". Their characteristics are a large local concentration of vertices or clustering (the vertices have many common neighbors) and, at the same time, a small average distance and diameter. Other properties present in some real complex systems are that their degrees follow a power law [1] and modularity (sometimes related to the existence of communities or clusters) [9, 4]. Thus, it make sense to consider different graph families when modeling a cascading failure process.

In [12], WR studied the vulnerability of the western US and Canada electric grid, modeled as a graph, from the failure of some sets of vertices. Their model for cascading failures, following the previous work of Motter and Lai[6], is very simple as each vertex has an associated load which is computed from its degree and the degree of its neighbors. Vertices have also a maximum capacity. If a vertex fails, its load is distributed to all its neighbors and if their new load becomes larger than this capacity, they also fail. The most important result is that the collapse of a network is triggered more easily from the failure of a few nodes of low degree than the failure of nodes of high degree. From their model we see that WR actually selects the set of initial failing vertices from values of their degree centrality. Clearly, there is need to go beyond this simple model and consider other centralities which could reflect better a dynamic flow process in a real network.

Our approach. In this research we consider different families of model graphs and also data available for real systems (US and European power grids and airport networks, human interactome etc.), and we compare the classical WR model with new cascading failure models based on other relevant graph centralities. In this way we can study which topological and dynamic parameters of a network are most likely to affect the propagation (cascading) of failures.

The new centralities are based on graph parameters and invariants like usual distance measures, the *betweenness* of a vertex, which reflects how many short paths between all pairs of possible vertices go through a given vertex, *communicability* [3] which measures the set of paths that begin and end in a vertex, and others based on the eigenvectors of the graph Laplacian and adjacency matrices, like PageRank.

All these centralities are a significant improvement with respect to the usual degree centrality from WR, which only accounts for direct links to a vertex. As an example, the PageRank of a vertex depends on the PageRank value of all vertices in the graph; vertices that are several edges apart contribute less to the calculation. Thus, a vertex that is linked (directly or through others) to many vertices which have a high PageRank value receives a high rank itself and it is said to be more central.

With this study, we want to know which sets of nodes can produce a maximum cascading failure for each different graph family and centrality.

A cascading failure general model. Each node starts with an initial load L_j which depends on the centrality that we are studying, and an initial maximum capacity, C_j . This load and capacity are defined as $L_j = [c_j(\sum_m c_m)]^\alpha$ and $C_j = T \cdot L_j$, where c_j is the centrality of vertex j , m runs on the set of adjacent vertices, α is a tunable parameter which controls the strength of the initial load and T is the tolerance parameter ($T \geq 1$). Once these parameters are fixed, the next steps are:

- Sort all vertices by their load L_j and select (initial failing sets) N_{IFS} vertices with the highest load, N_{IFS} with the lowest load and N_{IFS} with a load value around the median.
- For a given load group consider, independently, the failure of each vertex and distribute its load to active neighbours. If i is the failing vertex and j an active adjacent vertex then: $L_j^{\text{new}} = L_j + \Delta L_{ji}$ where $\Delta L_{ji} = L_j \frac{L_j}{\sum_{m \in \Gamma_i} L_m}$ is the contribution of extra load received from the set of failing neighbours Γ_i . Therefore an adjacent vertex with a higher load will receive a higher shared load from the the failing vertex.
- When the load has been distributed to its neighbouring vertices, check if any of the vertices affected exceeds its maximum capacity C_j . If this is the case, these vertices will fail and their load redistributed as explained. This procedure is repeated until the remaining active vertices stabilize or all vertices fail.
- When the cascading process is over, we count the vertices that have failed due to the failure of the initial vertex i , CF_i , and repeat the process with the remaining vertices in the same load group.
- To measure the robustness of the whole graph, we calculate CF_{IFS} as $CF_{\text{IFS}} = \frac{\sum_{i \in \text{IFS}} CF_i}{N_{\text{IFS}}(N-1)}$ where IFS and N_{IFS} represent the initial failing set of vertices and its cardinality, respectively.

Note that the original cascading failure model of Wang and Rong, corresponds to consider for c_i the degree centralities.

Methodology. We have considered ten topologically different graph families: Geographical Threshold 2D, Geographical Threshold 3D, Watts-Strogatz (high clustering), Watts-Strogatz (low clustering), Barabasi-Albert, Erdős - Rényi, Power-law Clustered, Random Geometric, Random Partition, Random Regular. See the NetworkX documentation [7] for details on each family and associated bibliography.

The centralities used in our study are: Degree, Betweenness, Communicability, Closeness Current Flow, PageRank and Eigenvector [7, 5].

We have coded all cascading failure methods in Python 2.7 while using the NetworkX package 1.10 [7] to generate all graphs and call its preprogrammed centrality functions.

For each combination of a graph family, centrality and α value (0.1 and 0.5), we run a set of 20 simulations for 20 different graphs with the same order $|V| = 100$ and size $|E| \approx 400$ from this graph family (these graphs are saved and used for each other centrality). Each run

involves increasing the load tolerance parameter from 1 to 1.5 in steps of 0.025. The results are averaged for these 20 simulations.

As an example of the results obtained, the following two figures compare, for Power-law Clustered graphs, cascading failure processes based on the WR model of degree centrality (left) with the closeness current flow centrality model (right), both with parameter $\alpha = 0.1$.

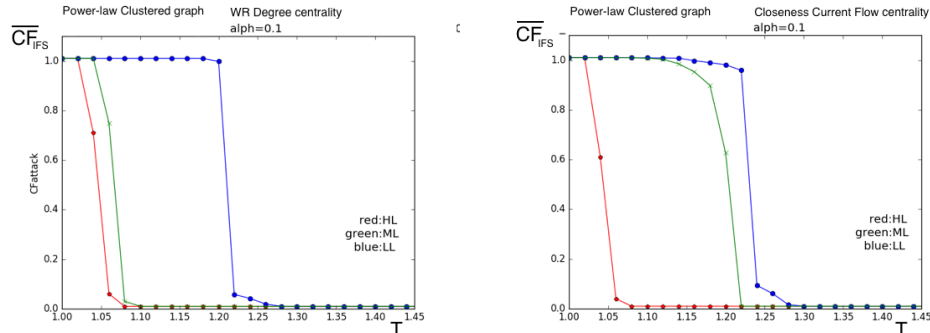

Both figures represent \overline{CF}_{IFS} versus T . We note a clear different behavior with respect to the two centralities when the initial failing vertices have a load around the median.

Results. Our results show, as expected, a different behavior among graph families and centralities. However in many cases cascading failure sizes depend on the load of the initial vertices in a similar way to the results obtained by Wang and Rong, which we have reproduced validating our methods. But, when checking, for a given graph family, the effects of selecting the initial failing nodes according to different centralities show a pattern: With cascading failure models based on centralities like Betweenness and Communicability, all three load options for the initial failing set lead to no cascading failures for small values of the tolerance parameter. Models based on the Closeness Current Flow and Pagerank centralities, on the other hand, show graph global failures at higher values of the tolerance. This reflects the fact that, for the former centralities, a high load for a vertex means that it is well connected through shortest paths to nearby vertices (and all other vertices) and this facilitates a redistribution of loads. For the latter centralities a high load means a more diffuse connection to all vertices.

We have also found for some models a clearly different behavior with respect to the WR results for initial failing sets of median loads, see the figure above. All these results suggest that, to increase a graph resilience, and thus to protect a real life network associated to it, there is need to decide which centrality can model better flows in the network and check all vertices according to it to select those vulnerable following all former criteria and not just by considering their degrees as it happens in most of the current models for cascading failures.

References

- [1] A.-L. Barabasi , R. Albert. Emergence of scaling in random networks. In **Science** 286, (1999) 509-512. doi:10.1126/science.286.5439.509.
- [2] S.V. Buldyrev, R. Parshani, G. Paul, H. E. Stanley, S. Havlin. Catastrophic cascade of failures in interdependent networks. In **Nature** 464 (2010) 1025-1028. doi:10.1038/nature08932.
- [3] E. Estrada. The communicability distance in graphs. In **Linear Algebra Appl.** 436 (2012) 4317-4328. doi: 10.1016/j.laa.2012.01.017.
- [4] G. Lin, Z. Di, Y. Fan. Cascading failures in complex networks with community structure. In **nt. J. Mod. Phys.** 25, (2014), 1440005. doi: 10.1142/S0129183114400051.
- [5] E. Estrada, P. A. Knight A First Course in Network Theory. Oxford University Press, Oxford, UK, 2015

- [6] A.E. Motter, Y.C. Lai. Cascade-based attacks on complex networks. In **Phys. Rev. E.** 66 (2002) 065102. doi:10.1103/PhysRevE.66.065102.
- [7] NetworkX documentation. <https://networkx.github.io/documentation/networkx-1.10/>. Accessed 29 June 2019.
- [8] L. Sánchez Marin. Cascading Failures in Complex Networks. TFG EETAC-UPC. June 13, 2018.
- [9] R.V. Solé, S. Valverde. Information theory of complex networks: on evolution and architectural constraints. In **Lecture Notes in Phys.** 650 (2004), 189 – 207. doi:10.1007/978-3-540-44485-5_9+.
- [10] R. Spiewak, S. Soltan, Y. Forman, S.V. Buldyrev, G. Zussman. A study of cascading failures in real and synthetic power grid topologies. In **Network Science** 1-21. Pub. online: 23-Aug-2018. doi:10.1017/nws.2018.14.
- [11] V. Turau, C. Weyer. Cascading failures caused by node overloading in complex networks. 2016 Joint Workshop on Cyber- Physical Security and Resilience in Smart Grids (CPSR-SG) doi:10.1109/CPSRSG.2016.7684104.
- [12] J.W. Wang, L.L. Rong. Cascade-based attack vulnerability on the US power grid. In **Safety Science** 47 (2009) 1332-1336. doi:10.1016/j.ssci.2009.02.002.
- [13] D.J. Watts, S. H. Strogatz. Collective dynamics of small-world networks. In **Nature** 93 (1998) 440-442. doi:10.1038/30918.
- [14] Y. Yang, T. Nishihawa, A.E. Motter. Small vulnerable sets determine large network cascades in power grids. In **Science** 358 (2017) eaan3184. 10.1126/science.aan3184.

Graph Unfoldings, Graph Coverings, and Regular Trees

Bruno Courcelle, and Yves Métivier

LaBRI, University of Bordeaux and INP France

EXTENDED ABSTRACT

The first goal of this work was to present a proof of Leighton's *graph covering* Theorem [10] in terms of regular trees. The study of coverings is motivated in particular by *distributed computing*. This led us to studying weighted graphs, trees, and (strongly) regular trees. These trees have no order between nodes (as have syntactic trees of terms) and they may have infinite degree, thanks to our new notion of weight.

We obtain easily an analog of Leighton's theorem to the case of *unfoldings* of finite (possibly weighted) directed graphs, frequently discussed as *transition systems* in a semantical perspective.

Regarding Leighton's Theorem, we have an easy proof in a special case, covering the case of regular graphs.

1 Coverings and Universal Cover of a Graph

We consider finite, undirected graphs having possibly loops or multi-edges. We write $G \simeq G'$ whenever G and G' are isomorphic. The set of all the edges of G incident with v is denoted by $I_G(v)$.

We say that a graph G is a *covering* of a graph H via γ if γ is a surjective homomorphism from G onto H such that for every vertex v of G the restriction of γ to $I_G(v)$ is a bijection onto $I_H(\gamma(v))$ [5, 6].

Let G be a graph and v a vertex. Following Angluin [2] (and Leighton's presentation [10]), the *universal cover* of G with respect to v , denoted $U(G, v)$, is the tree defined as follows:

- its vertex set is $\{w \mid w \text{ is a walk, starting at } v, \text{ that does not traverse the same edge in opposite directions twice in consecutive steps}\}$,
- and an edge in $U(G, v)$ links w_1 and w_2 , if w_1 is a one-edge extension of w_2 or vice-versa.

remark The universal cover $U(G, v)$ is unique up to isomorphism and independent of the choice of the vertex v . It is denoted by $U(G)$.

The theory of *distributed computing* uses the notion of (universal) covering of graphs. Distributed algorithms such as the one for *election* require the network to reach a non-symmetric state. It is not difficult to see that similarity of infinite radius may exist in finite graphs. It is precisely captured by the notion of covering used by Angluin [2]. Networks in which symmetries exist are non-minimal for the covering relation and the impossibility of breaking symmetry can be shown for these graphs. In particular, the election problem has no deterministic distributed solution. Coverings are also used for impossibility proofs concerning the *consensus problem* [9], and for the study of *simulation* of large networks on smaller networks [5].

Leighton [10] proves that if finite graphs G and H have isomorphic universal coverings, then they have a finite common covering. This result was conjectured by Angluin [2], and first proved in the case of regular graphs by Angluin and Gardiner [3]. The proof of Leighton uses combinatorial tools from graph theory (as the degree refinement of a graph) and it does not give much structural information. In this framework, Norris [13] proves that the isomorphism of universal covers of graphs of size n until depth $n - 1$ implies isomorphism at all depths.

Several works developed in different contexts yield different proofs of the results of Angluin-Gardiner and of Leighton. They use combinatorial, topological or group theory tools: [1, 4, 11, 14, 15].

2 Unfoldings and Coverings Treated Similarly

The *complete unfolding* of a directed graph from a vertex (called an *origin*) defines a tree that is infinite if the graph has directed cycles. Formally, it is the tree of directed walks in the graph. It has been introduced in the case where the graph is a *transition system* (an abstract program) and its complete unfolding represents its semantics [7, 8]. If the graph is finite, its complete unfolding is a regular tree (without ordering between the sons of a node). We call *unfolding*, a graph that approximates the complete unfolding.

Let us make precise that the notion of a *regular tree* has nothing to do with that of a regular graph. Every finite tree is regular. Hence, this notion concerns infinite trees. Similarly, *strongly regular trees* have nothing to do with strongly regular graphs.

Unfoldings and coverings are defined similarly in terms of surjective graph homomorphisms that are locally bijective. This *locality notion* is a parameter that gives rise to several types of unfoldings or coverings. For unfoldings, the "neighbourhood" is the set of outgoing edges from any vertex (any "state" in a transition system). For coverings, it is the set of all incident edges to a vertex. Yet other notions can be defined.

3 Our Results

In this communication, we develop in parallel both notions. We establish for complete unfoldings existing results for universal coverings, in particular the theorems by Leighton and Norris presented above.

The main new definitions and results are as follows:

1. We define coverings and unfoldings for *weighted graphs*. The weight of an edge (or of an *half-edge*) is a positive integer or the infinite cardinal ω . A directed edge of weight 3 (resp. ω) unfolds into 3 edges (resp. countably many edges). In this way, we obtain trees with nodes of countable degree. The universal covering of an edge with half-edges of weights 3 and 4 is the infinite tree whose nodes have degree 3 or 4, and two adjacent nodes have different degrees.
2. We extend to complete unfoldings of weighted directed graphs the above mentioned theorems by Norris and Leighton. We give an easy proof of Leighton's Theorem for a special case, including the case of regular graphs [3]. We show why this proof does not extend to the general case.
3. The complete unfoldings of finite weighted directed graphs are the *regular rooted trees* (regular in a new sense, allowing infinite degree). The universal coverings of finite weighted graphs are trees without root that we call *strongly regular*. A tree is strongly regular if it yields finitely many regular trees, up to isomorphism, obtained by taking the different nodes as a roots. We give equivalent characterizations of strongly regular trees. We can decide if a regular tree is strongly regular.
4. Finite weighted graphs are thus *finite descriptions* of regular and strongly regular trees. *Canonical* such descriptions can be computed. It is no surprize that the associated isomorphism problems of the defined trees are decidable.

References

- [1] J. Abello, M. R. Fellows and J. Stillwell, On the complexity and combinatorics of covering finite complexes, *Australasian J. Combinatorics*, 4: 103-112 (1991).
- [2] D. Angluin, Local and Global Properties in Networks of Processors (Extended Abstract), *Proceedings of the 12th Annual ACM Symposium on Theory of Computing*, April 28-30, 1980, Los Angeles, California, USA, 82-93 (1980).
- [3] D. Angluin and A. Gardiner, Finite common coverings of pairs of regular graphs, *J. Comb. Theory, Ser. B*, 30(2): 184-187 (1981).
- [4] H. Bass and R. Kulkarni, Uniform tree lattices, *Jour. of the American math. Society*, 3(4): 843-902 (1990).
- [5] H. L. Bodlaender, The Classification of Coverings of Processor Networks, *J. Parallel Distrib. Comput.*, 6(1): 166-182 (1989).
- [6] P. Boldi and S. Vigna, Fibrations of graphs, *Discrete Mathematics*, 243 (1-3): 21-66 (2002).
- [7] B. Courcelle, The Monadic Second-Order Logic of Graphs IX: Machines and their Behaviours, *Theor. Comput. Sci.* 151(1): 125-162 (1995).
- [8] B. Courcelle and I. Walukiewicz, Monadic Second-Order Logic, Graph Coverings and Unfoldings of Transition Systems, *Ann. Pure Appl. Logic* 92(1): 35-62 (1998).
- [9] M. J. Fischer, N. A. Lynch and M. Merritt, Easy Impossibility Proofs for Distributed Consensus Problems, *Distributed Computing*, 1(1): 26-39 (1986).
- [10] F. Leighton, Finite common coverings of graphs, *J. Comb. Theory, Ser. B* 33(3): 231-238 (1982).
- [11] B. Mohar, A common cover of graphs and 2-cell embeddings, *J. Comb. Theory, Ser. B* 40(1): 94-106 (1986).
- [12] W. D. Neumann, On Leighton's graph covering theorem, *Groups, Geometry, and Dynamics* 4: 863-872 (2011).
- [13] N. Norris, Universal Covers of Graphs: Isomorphism to depth $n - 1$ Implies Isomorphism to all Depths, *Discrete Applied Math.*, 56/1: 61-74, (1995).
- [14] Th. Tucker, Some topological graph theory for topologists: A sampler of covering space construction, *Lecture notes in mathematics*, (1440): 192-207 (1990).
- [15] J. Woodhouse, Revisiting Leighton's theorem with the Haar measure, *arXiv: 1806.08196v2* (submitted) (2018).

Harnessing the power of atoms¹

Konrad K. Dabrowski¹, Tomáš Masařík², Jana Novotná²,
Daniël Paulusma¹, and Paweł Rzażewski³,

¹ Durham University, South Road, Durham, UK

² University of Warsaw, Stefana Banacha 2, Warsaw, Poland

& Charles University, Malostranské náměstí 25, Praha, Czech Republic

³ Warsaw University of Technology, Koszykowa 75, Warsaw, Poland

EXTENDED ABSTRACT

A graph is H -free if it does not contain the graph H as an induced subgraph, and a graph is (H_1, H_2) -free if it is both H_1 -free and H_2 -free. Classes of H -free graphs and (H_1, H_2) -free graphs are *hereditary*, that is, closed under vertex deletion. A graph class \mathcal{G} has *bounded* clique-width if there exists a constant c such that every graph in \mathcal{G} has clique-width at most c ; otherwise \mathcal{G} has unbounded clique-width. Recently, a detailed survey was published about the boundedness of clique-width for hereditary graph classes [4]. This survey includes an almost complete classification for (H_1, H_2) -free graphs (five open cases remain).

It is well known that many NP-complete graph problems are polynomial-time solvable on classes of bounded-clique-width; see [2, 10] for examples of such meta-theorems. A clique K in a connected graph G is a *clique cut-set* of G if $G - K$ is disconnected. A graph G is an *atom* if it is connected and has no clique cut-set. Decomposition into atoms is a widely used technique for solving algorithmic graph problems on hereditary graph classes. In particular, Tarjan [11] showed that the well-known problems COLOURING and MINIMUM INDEPENDENT SET are polynomial-time solvable on a hereditary graph class \mathcal{G} if and only if they are polynomial-time solvable on the atoms of \mathcal{G} .

Due to the above, our research aim is to identify the hereditary graph classes of *unbounded* clique-width whose atoms have *bounded* clique-width. Gaspers et al. [6] showed that for a graph H , the class of H -free atoms has bounded clique-width if and only if H is an induced subgraph of P_4 (the 4-vertex path). This classification coincides with the classification for boundedness of clique-width on general graphs. This means that restricting to atoms does not help when we forbid only one forbidden induced subgraph. On the other hand, split graphs, which can be characterized by three forbidden induced subgraphs, namely $2P_2$, C_4 and C_5 [5], have unbounded clique-width [8], but their atoms are cliques and thus have clique-width at most 2. Hence, it is a natural question whether there exist classes of (H_1, H_2) -free graphs of unbounded clique-width whose atoms have bounded clique-width.

Gaspers et al. [6] showed the first positive result for the case of two forbidden induced subgraphs H_1 and H_2 by proving that atoms of (C_4, P_6) -free graphs have clique-width at most 18 (whereas the class of (C_4, P_6) -free graphs itself contains all split graphs and thus has unbounded clique-width). We also note that Cameron et al. [1] proved that (cap, C_4) -free odd-signable atoms have clique-width at most 48, whereas the corresponding (hereditary) class of all such graphs, which contains the class of split graphs, has unbounded clique-width.

We extend the result of [6] by initiating a systematic study on the boundedness of clique-width of (H_1, H_2) -free atoms. We prove that the atoms of many graph classes of (H_1, H_2) -free graphs of unbounded clique-width still have unbounded clique-width. We do this by using or modifying existing constructions for showing unboundedness of clique-width. However, as our main result, we also identify a new class of (H_1, H_2) -free graphs of unbounded clique-width whose atoms have bounded clique-width.

Theorem 1 *The class of $(2P_2, \overline{P_2 + P_3})$ -free atoms has bounded clique-width (whereas the class of $(2P_2, \overline{P_2 + P_3})$ -free graphs has unbounded clique-width).*

¹Dabrowski and Paulusma were supported by the Leverhulme Trust (RPG-2016-258). Masařík and Novotná were supported by Charles University student grants (SVV-2017-260452 and GAUK 1277018) and GAČR project (17-09142S). Rzażewski was supported by the London Mathematical Society (41744) and the Polish National Science Centre (2018/02/X/ST6/00145).

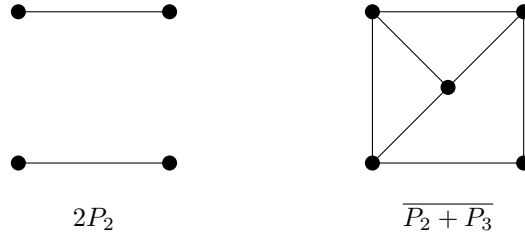

Figure 1: The forbidden induced subgraphs from Theorem 1.

Note that the class of $(2P_2, \overline{P_2 + P_3})$ -free graphs (see Figure 1 for pictures of the forbidden graphs) contains the class of split graphs and thus has unbounded clique-width. The proof of the main statement in Theorem 1 is partially based on the proof of a result of Malyshev and Lobanova [9], who showed that COLOURING is polynomial-time solvable on the class of $(P_5, \overline{P_2 + P_3})$ -free graphs.

Their proof is split into two parts. First, they assume the presence of an induced C_5 . They show that the prime (with respect to modular decomposition) induced subgraphs of $(P_5, \overline{P_2 + P_3})$ -free atoms with an induced C_5 either have a bounded number of vertices [9, Lemmas 5–9] (in which case the clique-width is bounded) or are $3P_1$ -free. In both cases, the (weighted) COLOURING problem can be solved in polynomial time. Second, they observe that $(P_5, C_5, \overline{P_2 + P_3})$ -free graphs are perfect and thus admit a polynomial-time algorithm for COLOURING [7].

For the proof of Theorem 1 we distinguish the same two cases. We first show that the class of $(2P_2, \overline{P_2 + P_3}, 3P_1)$ -free graphs with an induced C_5 has bounded clique-width. Then, as the clique-width of a graph is equal to the maximum clique-width of its prime induced subgraphs [3], the first case follows from the above result of [9]. That is, $(2P_2, \overline{P_2 + P_3})$ -free atoms that contain an induced C_5 have bounded clique-width. In the second case, we consider $(2P_2, \overline{P_2 + P_3}, C_5)$ -free atoms. A non-trivial analysis into the structure of $(2P_2, \overline{P_2 + P_3}, C_5)$ -free atoms is needed to prove boundedness of their clique-width, and this is where our main contribution lies.

References

- [1] K. Cameron, M.V.G. da Silva, S. Huang, and K. Vušković. Structure and algorithms for (cap, even hole)-free graphs. *Discrete Mathematics*, 341:463–473, 2018.
- [2] B. Courcelle, J. A. Makowsky, and U. Rotics. Linear time solvable optimization problems on graphs of bounded clique-width *Theory of Computing Systems*, 33:125–150, 2000.
- [3] B. Courcelle and S. Olariu. Upper bounds to the clique width of graphs. *Discrete Applied Mathematics*, 101:77–114, 2000.
- [4] K.K. Dabrowski, M. Johnson, and D. Paulusma. Clique-width for hereditary graph classes. *London Mathematical Society Lecture Note Series*, 456:1–56, 2019.
- [5] S. Földes and P.L. Hammer. Split graphs. *Congressus Numerantium*, XIX:311–315, 1977.
- [6] S. Gaspers, S. Huang, and D. Paulusma. Colouring square-free graphs without long induced paths. *Journal of Computer and System Sciences*, 106:60–79, 2019.
- [7] M. Grötschel, L. Lovász, and A. Schrijver. Polynomial algorithms for perfect graphs. *Annals of Discrete Mathematics*, 21:325–356, 1984.

- [8] J.A. Makowsky and U. Rotics. On the clique-width of graphs with few P_4 's. *International Journal of Foundations of Computer Science*, 10:329–348, 1999.
- [9] D.S. Malyshev and O.O. Lobanova. Two complexity results for the vertex coloring problem. *Discrete Applied Mathematics*, 219:158–166, 2017.
- [10] M. Rao. MSOL partitioning problems on graphs of bounded treewidth and clique-width. *Theoretical Computer Science*, 377:260–267, 2007.
- [11] R.E. Tarjan. Decomposition by clique separators. *Discrete Mathematics*, 55:221–232, 1985.

Hull number in the convexity of induced paths of order up to $k \geq 3$

Mitre C. Dourado ¹, Lucia D. Penso ², and Dieter Rautenbach ²

¹ Instituto de Matemática, Universidade Federal do Rio de Janeiro, Rio de Janeiro, Brazil,
email: mitre@dcc.ufrj.br

² Institute of Optimization and Operations Research, Ulm University, Ulm, Germany,
email: {lucia.penso,dieter.rautenbach}@uni-ulm.de

EXTENDED ABSTRACT

A set S of vertices of a graph G is P_3^* -convex if there is no vertex outside S having two non-adjacent neighbors in S . The P_3^* -convex hull of S is the minimum P_3^* -convex set containing S . If the P_3^* -convex hull of S is $V(G)$, then S is a P_3^* -hull set. The minimum size of a P_3^* -hull set is the P_3^* -hull number of G . In this talk, we show that the problem of deciding whether the P_3^* -hull number of a chordal graph is at most k is NP-complete, present polynomial algorithms to determine this parameter and provide a minimum P_3^* -hull set for subclasses of the chordal graph superclass [4], discuss how to extend those results to a broader class of convexities, and comment on some related open problems.

Here we consider finite, undirected, and simple graphs. The path with k vertices is denoted by P_k and an *induced path* is a path having no chords. Given a set S of vertices of a graph G , the *interval of S in the convexity of induced paths of order 3*, also known as the P_3^* convexity, is the set $[S]_3^* = S \cup \{u : u \text{ belongs to an induced } P_3 \text{ between two vertices of } S\}$. The set S is P_3^* -convex if $S = [S]_3^*$ and is P_3^* -concave if $V(G) \setminus S$ is P_3^* -convex. The P_3^* -convex hull of S is the minimum P_3^* -convex set containing S and it is denoted by $\langle S \rangle_3^*$. If $\langle S \rangle_3^* = V(G)$, then S is a P_3^* -hull set. The minimum size of a P_3^* -hull set is the P_3^* -hull number $h_3^*(G)$ of G . Finally, the distance between vertices u and v is here denoted by $d(u, v)$ and the neighborhood of a vertex v is denoted by $N(v)$. The set $\{1, \dots, k\}$ for an integer $k \geq 1$ is denoted by $[k]$. A subgraph of G induced by vertex set S is denoted by $G[S]$. A vertex u is *simplicial* if its neighborhood induces a complete graph. Note that every P_3^* -hull set contains all simplicial vertices and at least one vertex of each P_3^* -concave set of the graph.

Recently, the P_3^* convexity has attracted attention as an alternative to other quite known convexities with different behavior despite a similar definition. It is particularly interesting in spreading dynamics which forbid the same influence by two neighbors to get spread to a common neighbor. For instance, in [1], it is shown that the problem of deciding whether the P_3^* -hull number of a bipartite graph is at most k is NP-complete, while polynomial-time algorithms for determining this parameter for P_4 -sparse graphs and cographs are presented. Apart from these results very little is known, as results of quite similarly defined well-known convexities do not help, since the proofs depend on the existence of longer shortest paths or a non-induced P_3 .

Theorem 1 *Given a chordal graph G and an integer k , it is NP-complete to decide whether $h_3^*(G) \leq k$.*

Proof: Since the P_3^* -convex hull of a set can be computed in polynomial time, the problem of deciding whether $h_3^*(G) \leq k$ belongs to NP.

In order to prove NP-completeness, we describe a polynomial reduction from a restricted version of SATISFIABILITY. Let \mathcal{C} be an instance of SATISFIABILITY consisting of m clauses C_1, \dots, C_m over n boolean variables x_1, \dots, x_n such that every clause in \mathcal{C} contains at most three literals and, for every variable x_i , there are exactly two clauses in \mathcal{C} , say $C_{j_i^1}$ and $C_{j_i^2}$, that contain the literal x_i , and exactly one clause in \mathcal{C} , say $C_{j_i^3}$, that contains the literal \bar{x}_i , and these three clauses are distinct. Using a polynomial reduction from [LO1] [5], it has been shown in [3] that SATISFIABILITY restricted to such instances is still NP-complete.

Let the graph G be constructed as follows starting with the empty graph:

- For every $j \in [m]$, add a vertex c_j .

- For every $i \in [n]$, add 10 vertices $x_i, y_i, z_i, x_i^1, x_i^2, w_i^1, w_i^2, \bar{x}_i, \bar{y}_i, \bar{w}_i$ and 17 edges to obtain the subgraph indicated in Figure 1.
- Add a vertex z and the edges to make a clique of $C \cup Z \cup \{z\}$, where

$$C = \{c_j : j \in [m]\} \text{ and}$$

$$Z = \{z_i : i \in [n]\}.$$

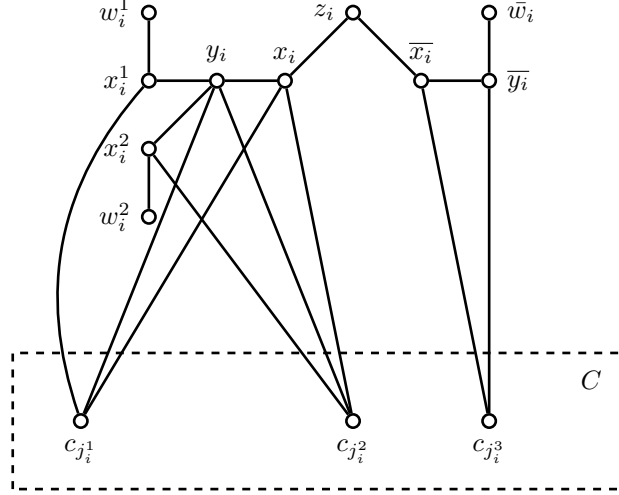

Figure 1: When the construction of G ends, z_i will belong to the clique $C \cup \{z_1, \dots, z_n\} \cup \{z\}$.

The graph G is now constructed. Note that the order of G is $10n + m + 1$. In order to show that G is chordal, we indicate a *perfect elimination ordering*, which is a linear ordering $v_1, \dots, v_{10n+m+1}$ of its vertices such that v_1 is simplicial in G and v_i is simplicial in $G \setminus \{v_1, \dots, v_{i-1}\}$ for every $i \in [10n + m + 1] \setminus [1]$. Such an ordering is obtained by

- starting with the vertices w_i^1, w_i^2 , and \bar{w}_i for all $i \in [n]$ (in any order),
- continuing with the vertices x_i^1 and x_i^2 for all $i \in [n]$,
- continuing with the vertices y_i, \bar{y}_i for all $i \in [n]$,
- continuing with the vertices x_i and \bar{x}_i for all $i \in [n]$, and
- ending with the vertices in the clique $C \cup Z \cup \{z\}$.

Setting $k = 4n + 1$, we have to show that \mathcal{C} is satisfiable if and only if G contains a P_3^* -hull set of order at most k .

To prove necessity, let \mathcal{S} be a satisfying truth assignment of \mathcal{C} .

Let

$$S = \{z\} \cup \bigcup_{i \in [n]} \{w_i^1, w_i^2, \bar{w}_i\} \cup \bigcup_{i \in [n]: x_i \text{ true in } \mathcal{S}} \{x_i\} \cup \bigcup_{i \in [n]: x_i \text{ false in } \mathcal{S}} \{\bar{x}_i\}.$$

Clearly, $|S| = k = 4n + 1$. For every $i \in [n]$, either $z_i \in [\{x_i, z\}]_3^*$ or $z_i \in [\{\bar{x}_i, z\}]_3^*$. Thus, $z_i \in [S]_3^*$.

Since \mathcal{S} is a satisfying truth assignment, for every $j \in [m]$, there is a neighbor, say v , of c_j in

$$\bigcup_{i \in [n]: x_i \text{ true in } \mathcal{S}} \{x_i\} \cup \bigcup_{i \in [n]: x_i \text{ false in } \mathcal{S}} \{\bar{x}_i\}.$$

Then $c_j \in [\{v, z\}]_3^*$. Hence $C \cup Z \subseteq [S]_3^*$.

Now, for $i \in [n]$, we have $x_i^1 \in [\{w_i^1, c_{j_1^1}\}]_3^*$, $x_i^2 \in [\{w_i^2, c_{j_2^1}\}]_3^*$, $\bar{y}_i \in [\{\bar{w}_i, c_{j_3^1}\}]_3^*$, $y_i \in [\{x_i^1, x_i^2\}]_3^*$, $x_i \in [\{y_i, z_i\}]_3^* \cup S$, and $\bar{x}_i \in [\{\bar{y}_i, z_i\}]_3^* \cup S$. (See Figure 1). Altogether, we obtain that S is a P_3^* -hull set of G of order $4n + 1$. Now, to prove sufficiency, let S be a hull set of G of order at most $4n + 1$.

First Claim: For every $i \in [n]$, set $\{x_i, z_i, \bar{x}_i\}$ is P_3^* -concave.

Proof: The set $\{x_i, z_i, \bar{x}_i\}$ is P_3^* -concave as $N(x_i) \setminus \{z_i\}$, $N(z_i) \setminus \{x_i, \bar{x}_i\}$, and $N(\bar{x}_i) \setminus \{z_i\}$ are cliques. \square

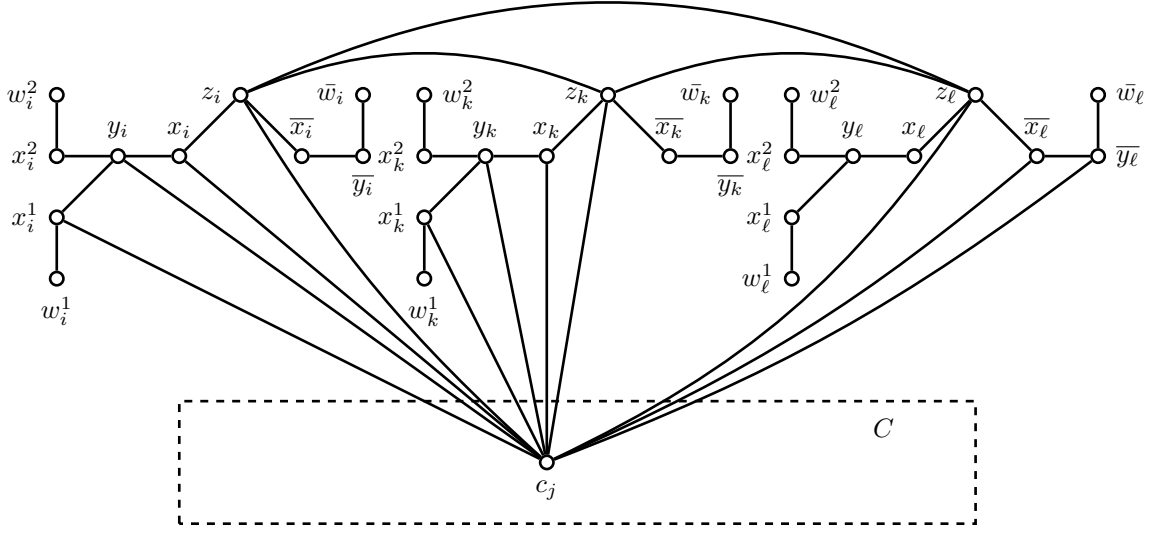

Figure 2: $V_j = \{c_j, x_i, y_i, x_i^1, x_k, y_k, x_k^1, \bar{x}_l, \bar{y}_l\}$ for $C_j = \{x_i, x_k, \bar{x}_l\} = C_{j_1^1} = C_{j_k^1} = C_{j_l^3}$.

Now, for $j \in [m]$, define

$$V_j = \{c_j\} \cup \bigcup_{i \in [n]: j=j_i^1} \{x_i, y_i, x_i^1\} \cup \bigcup_{i \in [n]: j=j_i^2} \{x_i, y_i, x_i^2\} \cup \bigcup_{i \in [n]: j=j_i^3} \{\bar{x}_i, \bar{y}_i\}.$$

Second Claim: The set V_j is P_3^* -concave in G for every $j \in [m]$.

Proof: First, suppose that C_j contains the positive literal x_i . By symmetry, w.l.o.g., we may assume that $j_1^1 = j$ and $j_2^1 = j'$ for some $j' \in [m] \setminus \{j\}$. (See Figure 2). Observe that, for $v \in \{x_i, y_i, x_i^1\}$, it holds $N(v) \setminus V_j$ is a clique. Then, no induced P_3 between two vertices in $V(G) \setminus V_j$ contains $v \in \{x_i, y_i, x_i^1\}$.

Next, suppose that C_j contains the negative literal \bar{x}_i . Observe that, for $v \in \{\bar{x}_i, \bar{y}_i\}$, it holds $N(v) \setminus V_j$ is a clique. Then, no induced P_3 between two vertices in $V(G) \setminus V_j$ contains $v \in \{\bar{x}_i, \bar{y}_i\}$.

Finally, since $N(c_j) \setminus V_j$ is a clique, no induced P_3 between two vertices in $V(G) \setminus V_j$ contains c_j , which completes the proof of the claim. \square

Note that all $3n + 1$ simplicial vertices of G , namely, $\{z\} \cup \bigcup_{i \in [n]} \{w_i^1, w_i^2, \bar{w}_i\}$, belong to S . Since S contains at most n non-simplicial vertices, the first claim implies that, for every $i \in [n]$, the set S contains exactly one of the three vertices in $\{x_i, z_i, \bar{x}_i\}$, and that these are the only non-simplicial vertices in S . Now, the second claim implies that, for every $j \in [m]$, there is some $i \in [n]$ such that

- either C_j contains the literal x_i and the vertex x_i belongs to S
- or C_j contains the literal \bar{x}_i and the vertex \bar{x}_i belongs to S .

Therefore, setting the variable x_i to true if and only if the vertex x_i belongs to S yields a satisfying truth assignment \mathcal{S} of \mathcal{C} , which completes the proof. \square

Now, given a set S of vertices of a graph G and an integer $3 \leq \ell \leq d(G)$, define in a more general way the *interval of S in the convexity of induced paths of order at most ℓ* , called here P_ℓ^* *convexity*, to be the set $[S]_3^* = S \cup \{u : u \text{ belongs to an induced } P_i \text{ between two vertices of } S \text{ for some } i \leq \ell\}$. The terms P_ℓ^* -*convex*, P_ℓ^* -*concave*, P_ℓ^* -*convex hull of S* , P_ℓ^* -*hull set*, and P_ℓ^* -*hull number $h_\ell^*(G)$ of G* are then defined in a similar way to the geodetic and the P_3^* convexities. Note that this more ample definition provides us with a family of distinct convexities, where the extreme values of ℓ give us already well-known ones: by setting $\ell = 3$ we get the P_3^* *convexity* while by setting $\ell = d(G)$ we get the geodetic convexity. The next corollary shows that the proof of Theorem 1 also works in all such convexities, thus yielding a more simple and shorter proof (half the size) than the already known NPC result for chordal graphs in the geodetic convexity [2] (from which Theorem 1 cannot be derived due to the usage of induced paths of order larger than 3).

Corollary 2 *Given a chordal graph G , an integer k , and an integer $3 \leq \ell \leq d(G)$, it is NP-complete to decide whether $h_\ell^*(G) \leq k$.*

Proof: Consider the very same proof as in Theorem 1. In the necessity direction, all nodes are generated by induced paths of order 3, which are also present in the interval of a set in the P_ℓ^* convexity. In the sufficiency direction, the neighbors of $\{x_i, z_i, \bar{x}_i\}$ in the first claim always form a clique, while the neighbors of $v \in V_j$ not belonging to V_j in the second claim always form a clique as well, and hence, there is no induced path between two nodes outside V_j which intersects V_j . Therefore, the proof also holds for the P_ℓ^* convexity, given an integer $3 \leq \ell \leq d(G)$. \square

Finally, we close the talk by showing polynomial algorithms obtaining the h_3^* -hull number and a minimum P_3^* -hull set for subclasses of chordal graphs [4] which can be adapted as well to a broader class of convexities, and by commenting on related open problems.

References

- [1] R.T. Araújo, R.M. Sampaio, V.F. dos Santos, J.L. Szwarcfiter. The convexity of induced paths of order three and applications: Complexity aspects. *Discrete Appl. Math.* 237 (2018) 33–42.
- [2] S. Bessy, M.C. Dourado, L.D. Penso, D. Rautenbach. The Geodetic Hull Number is Hard for Chordal Graphs. *SIAM J. Discrete Math.*, 32(1) (2018) 543–547.
- [3] M.C. Dourado, L.D. Penso, D. Rautenbach. On the geodetic hull number of P_k -free graphs. *Theoret. Comput. Sci.* 640 (2016) 52–60.
- [4] M.C. Dourado, L.D. Penso, D. Rautenbach. The hull number in the convexity of induced paths of order 3. To appear in IWOCA 2019.
- [5] M. R. Garey, D. S. Johnson. *Computers and intractability: a guide to the theory of NP-completeness*. Freeman, New York, (1979).

Hypergraph matchings and blow-up lemmas

*Stefan Ehard*¹, *Stefan Glock*², and *Felix Joos*²

¹ Institute of Optimization and Operations Research, Ulm University, Germany

² School of Mathematics, University of Birmingham, United Kingdom

EXTENDED ABSTRACT

A hypergraph \mathcal{H} consists of a vertex set $V(\mathcal{H})$ and an edge set $E(\mathcal{H}) \subseteq 2^{V(\mathcal{H})}$. If all edges have size r , then \mathcal{H} is called *r-uniform*. A *matching* in \mathcal{H} is a collection of pairwise disjoint edges, and a *cover* of \mathcal{H} is a set of edges whose union contains all vertices. A matching is *perfect* if it is also a cover. These concepts are widely applicable, as ‘almost all combinatorial questions can be reformulated as either a matching or a covering problem of a hypergraph’ [6], and their study is thus of great relevance in combinatorics and beyond.

Results like Hall’s theorem and Tutte’s theorem that characterize when a graph has a perfect matching are central in graph theory. However, for each $r \geq 3$, it is NP-complete to decide whether a given r -uniform hypergraph has a perfect matching. It is thus of great importance to find sufficient conditions that guarantee a perfect matching or almost perfect matching in an r -uniform hypergraph. A celebrated theorem of Pippenger states that any almost regular hypergraph with small codegrees has an almost perfect matching. We show that one can find such an almost perfect matching which is ‘pseudorandom’, meaning that, for instance, the matching contains as many edges from a given set of edges as predicted by a heuristic argument. We further discuss applications of this result to obtain blow-up lemmas for rainbow embeddings and approximate graph decompositions.

1 Pseudorandom hypergraph matchings

For a hypergraph \mathcal{H} and vertices $u, v \in V(\mathcal{H})$, we define the degree and codegree as $\deg_{\mathcal{H}}(v) := |\{e \in E(\mathcal{H}) : v \in e\}|$ and $\deg_{\mathcal{H}}(uv) := |\{e \in E(\mathcal{H}) : \{u, v\} \subseteq e\}|$, respectively. Let $\Delta(\mathcal{H}) := \max_{v \in V(\mathcal{H})} \deg_{\mathcal{H}}(v)$, and $\Delta^c(\mathcal{H}) := \max_{u \neq v \in V(\mathcal{H})} \deg_{\mathcal{H}}(uv)$ denote the *maximum degree* and *maximum codegree* of \mathcal{H} , respectively.

To motivate our result on hypergraph matchings, suppose for simplicity that we are given a D -regular hypergraph and want to find an (almost) perfect matching \mathcal{M} . Moreover, we wish \mathcal{M} to be ‘pseudorandom’, that is, to have certain properties that we expect from an idealized random matching. In a perfect matching, at a fixed vertex, exactly one edge needs to be included in the matching, and assuming that each edge is equally likely to be chosen, we may heuristically expect that every edge of \mathcal{H} is in a random perfect matching with probability $1/D$. Thus, given a (large) set $E \subseteq E(\mathcal{H})$ of edges, we expect $|E|/D$ matching edges in E . More generally, given a set X , a *weight function on X* is a function $\omega : X \rightarrow \mathbb{R}_{\geq 0}$. For a subset $X' \subseteq X$, we define $\omega(X') := \sum_{x \in X'} \omega(x)$. If ω is a weight function on $E(\mathcal{H})$, the above heuristic would imply that we expect from a ‘pseudorandom’ matching \mathcal{M} that $\omega(\mathcal{M}) \approx \omega(E(\mathcal{H}))/D$. The following is a simplified version of our main theorem in [3] which asserts that a hypergraph with small codegrees has a matching that is pseudorandom in the above sense.

Theorem 1 ([3]) *Suppose $\delta \in (0, 1)$ and $r \in \mathbb{N}$ with $r \geq 2$, and let $\varepsilon := \delta/50r^2$. Then there exists Δ_0 such that for all $\Delta \geq \Delta_0$, the following holds: Let \mathcal{H} be an r -uniform hypergraph with $\Delta(\mathcal{H}) \leq \Delta$ and $\Delta^c(\mathcal{H}) \leq \Delta^{1-\delta}$ as well as $|E(\mathcal{H})| \leq \exp(\Delta^{\varepsilon^2})$. Suppose that \mathcal{W} is a set of at most $\exp(\Delta^{\varepsilon^2})$ weight functions on $E(\mathcal{H})$. Then, there exists a matching \mathcal{M} in \mathcal{H} such that $\omega(\mathcal{M}) = (1 \pm \Delta^{-\varepsilon})\omega(E(\mathcal{H}))/\Delta$ for all $\omega \in \mathcal{W}$ with $\omega(E(\mathcal{H})) \geq \max_{e \in E(\mathcal{H})} \omega(e)\Delta^{1+\delta}$.*

Let us discuss a few aspects of this theorem. First, note that we do not require \mathcal{H} to be almost regular but the theorem can be applied with any (sufficiently large) Δ . If \mathcal{H} is almost regular, an almost perfect matching can be obtained by considering the weight function $\omega \equiv 1$

which then yields that $|\mathcal{M}| \geq (1 - o(1)) \frac{|E(\mathcal{H})|}{\Delta(\mathcal{H})} \geq (1 - o(1))|V(\mathcal{H})|/r$, where the last inequality uses that $r|E(\mathcal{H})| = \sum_{x \in V(\mathcal{H})} \deg_{\mathcal{H}}(x) = (1 \pm o(1))|V(\mathcal{H})|\Delta(\mathcal{H})$.

Further, we remark that Theorem 1 is (qualitatively) more general than a similar theorem of Kahn [10] as well as the Alon–Yuster theorem [1, Theorem 1.2]. The Alon–Yuster theorem builds on a theorem of Pippenger and Spencer [14] and states that any almost regular hypergraph with small codegrees contains an almost perfect matching \mathcal{M} that covers a collection \mathcal{V} of subsets $U \subseteq V(\mathcal{H})$ almost completely. For each target subset $U \in \mathcal{V}$, we can define a weight function ω_U by setting $\omega_U(e) := |e \cap U|$. Note that $\omega_U(E(\mathcal{H})) = \sum_{x \in U} \deg_{\mathcal{H}}(x) = (1 \pm o(1))|U|\Delta(\mathcal{H})$. Thus, if $\omega_U(\mathcal{M}) = (1 \pm o(1))\omega_U(E(\mathcal{H}))/\Delta(\mathcal{H})$, we deduce that $|U \cap V(\mathcal{M})| = \omega_U(\mathcal{M}) = (1 \pm o(1))\omega_U(E(\mathcal{H}))/\Delta(\mathcal{H}) \geq (1 - o(1))|U|$, implying that almost all vertices of U are covered by \mathcal{M} .

In fact, we prove a more general theorem in [3] which not only allows weight functions on edges, but on tuples of edges. This allows, for instance, to specify a set of pairs of edges, and control how many pairs will be contained in the matching.

2 Applications

In this section, we provide two results on rainbow embeddings and approximate graph decompositions that use Theorem 1 (or its more general version) as a key ingredient.

2.1 A rainbow blow-up lemma

A subgraph of an edge-coloured graph is called rainbow if all its edges have different colours. We provide a rainbow version of the blow-up lemma of Komlós, Sárközy and Szemerédi [12] that applies for almost optimally bounded edge-colourings.

We call an edge-colouring *locally k -bounded* if each colour class has maximum degree at most k , and we call it *globally k -bounded* if any colour appears on at most k edges. The following is a special case of our rainbow blow-up lemma.

Theorem 2 ([4]) *Suppose H is a graph on at most n vertices with $\Delta(H) = \mathcal{O}(1)$. Then any locally $\mathcal{O}(1)$ -bounded and globally $(1 - o(1))\binom{n}{2}/e(H)$ -bounded edge-colouring of K_n contains a rainbow copy of H .*

Note that the assumption that the colouring is $(1 - o(1))\binom{n}{2}/e(H)$ -bounded is asymptotically best possible in the sense that if the colouring was not $\binom{n}{2}/e(H)$ -bounded, there might be less than $e(H)$ colours, making the existence of a rainbow copy of H impossible. Theorem 2 is very similar in spirit to the main result of Montgomery, Pokrovskiy and Sudakov [13] on embedding rainbow trees. Roughly speaking, instead of dealing with trees, our results apply to general graphs H , but we require H to have bounded degree, whereas one of the great achievements of [13] is that no such requirement is necessary when dealing with trees.

We derive Theorem 2 from an even more general ‘blow-up lemma’ for k -partite ‘super-regular’ graphs and collect some terminology. For a bipartite graph G with vertex partition (V_1, V_2) , we define the *density* of W_1, W_2 with $W_i \subseteq V_i$ by $d_G(W_1, W_2) := |E(G[W_1, W_2])|/|V_1||V_2|$. We say G is (ε, d) -*regular* if $d_G(W_1, W_2) = d \pm \varepsilon$ for all $W_i \subseteq V_i$ with $|W_i| \geq \varepsilon|V_i|$ and (ε, d) -*super-regular* if in addition $|N_G(v) \cap V_{3-i}| = (d \pm \varepsilon)|V_{3-i}|$ for each $i \in [2]$ and $v \in V_i$. If $c: E(G) \rightarrow C$ is an edge-colouring of a graph G and $\alpha \in C$, denote by $e_G^\alpha(S, T)$ the number of α -coloured edges of G with one endpoint in S and the other one in T .

We say that $(H, G, (X_i)_{i \in [r]}, (V_i)_{i \in [r]})$ is an (ε, d) -*super-regular blow-up instance* if

- H and G are graphs, $(X_i)_{i \in [r]}$ is a partition of $V(H)$ into independent sets, $(V_i)_{i \in [r]}$ is a partition of $V(G)$, and $|X_i| = |V_i|$ for all $i \in [r]$, and
- for all $ij \in \binom{[r]}{2}$, the bipartite graph $G[V_i, V_j]$ is (ε, d) -super-regular.

We say that $\phi: V(H) \rightarrow V(G)$ is an *embedding of H into G* if ϕ is injective and $\phi(x)\phi(y) \in E(G)$ for all $xy \in E(H)$. We also write $\phi: H \rightarrow G$ in this case. We say that ϕ is *rainbow* if $\phi(H)$ is rainbow. We now state our new rainbow blow-up lemma.

Theorem 3 (Rainbow blow-up lemma [4]) *For all $d, \gamma, \Delta, \Lambda, r$, there exists an $\varepsilon > 0$ and an $n_0 \in \mathbb{N}$ such that the following holds for all $n \geq n_0$. Suppose $(H, G, (X_i)_{i \in [r]}, (V_i)_{i \in [r]})$ is an (ε, d) -super-regular blow-up instance with $\Delta(H) \leq \Delta$. Assume further that*

- (i) $|V_i| = (1 \pm \varepsilon)n$ for all $i \in [r]$;
- (ii) $c: E(G) \rightarrow C$ is a locally Λ -bounded edge-colouring such that for all $\alpha \in C$:

$$\sum_{i,j \in \binom{[r]}{2}} e_G^\alpha(V_i, V_j) e_H(X_i, X_j) \leq (1 - \gamma)dn^2.$$

Then there exists a rainbow embedding ϕ of H into G such that $\phi(x) \in V_i$ for all $i \in [r]$ and $x \in X_i$.

In the following, we sketch how we employ Theorem 1 as a crucial tool in the proof of Theorem 3. We proceed cluster by cluster and find a partial embedding ϕ_i which maps almost all vertices of X_i into V_i and which is consistent with the partial embedding so far. Each such embedding step can be modeled as finding a rainbow matching in an auxiliary bipartite ‘candidacy graph’ A_i on (X_i, V_i) .

To illustrate this, we consider the following toy example and assume that A_i is the complete bipartite graph with bipartition (X_i, V_i) and $|X_i| = |V_i| = n$. Suppose further that $c: E(A_i) \rightarrow C$ is a proper edge-colouring of A_i . Our aim is to find an almost perfect rainbow matching in A_i . When the colouring is optimal, then finding such a matching of size $n - 1$ is equivalent to the famous Ryser–Brualdi–Stein conjecture on almost transversals in Latin squares. In order to apply our theorem, we formulate the problem as a hypergraph matching problem. Let \mathcal{H} be the hypergraph with vertex set $X_i \cup V_i \cup C$ and edge set $\{\{u, v, c(uv)\}: uv \in E(A_i)\}$. The key property of \mathcal{H} is the following bijection between the set of all rainbow matchings in A_i and the set of all matchings in \mathcal{H} – we simply assign a rainbow matching M in G to the matching $\mathcal{M} := \{\{u, v, c(uv)\}: uv \in M\}$ in \mathcal{H} . Clearly, $\Delta(\mathcal{H}) = n$ and $\Delta^c(\mathcal{H}) = 1$. The existence of an almost perfect rainbow matching in A_i follows now from Theorem 1. By considering the weight function $\omega \equiv 1$, we obtain a hypergraph matching \mathcal{M} of size $(1 - o(1))\frac{|E(\mathcal{H})|}{\Delta(\mathcal{H})} = (1 - o(1))n$ in \mathcal{H} and in turn a rainbow matching M in A_i of this size (this follows even already from Pippenger’s theorem).

In order to perform the embedding rounds for all candidacy graphs A_i , $i \in [r]$, repeatedly, we need to ensure that certain quasirandomness properties are preserved throughout the procedure. In our toy example this would mean, for instance, that for some specified sets $X'_i \subseteq X_i, V'_i \subseteq V_i$, we have $|E(A_i[X'_i, V'_i]) \cap M| \approx |X'_i||V'_i|/n$, and more generally that for sets $E' \subseteq E(A_i)$, we have $|E' \cap M| \approx |E'|/n$. This can be ensured utilizing weight functions as in Theorem 1 by defining $\omega_{E'}(e) = \mathbb{1}_{e \in E'}$ for all $e \in E(A_i)$.

In the end, ϕ_r will be a rainbow embedding that maps almost all vertices of H into G . Using a recent result of the second and third author [7] for $o(n)$ -bounded edge-colourings allows us to complete the embedding.

2.2 A blow-up lemma for approximate decompositions

Questions on packings and decompositions have a long history and lead to several beautiful conjectures which have driven a large amount of research. A prime example is the Oberwolfach problem where Ringel asked in 1967 whether one can decompose (the edge set of) K_{2n+1} into n copies of any 2-regular graph on $2n + 1$ vertices. This problem received considerable attention and Glock, Joos, Kim, Kühn and Osthus solved it for large n [8]. Possibly equally well-known is Ringel’s conjecture from 1963 stating that K_{2n+1} can be decomposed into any tree with n edges, as well as the tree packing conjecture due to Gyárfás and Lehel from 1976 stating that (the edge set of) K_n can be decomposed into any collection of trees T_1, \dots, T_n , where T_i has i vertices. Ringel’s conjecture has been solved approximately Montgomery, Pokrovskiy and Sudakov [13] using their aforementioned result on embedding rainbow trees together with a rotation technique, and both conjectures have been solved for bounded degree trees by Joos, Kim, Kühn and Osthus [9].

On a very high level, numerous decomposition results combine approximate decomposition results with certain absorbing techniques. For many questions in extremal combinatorics, the blow-up lemma due to Komlós, Sárközy and Szemerédi [12] in combination with Szemerédi’s regularity lemma has demonstrated its power and usefulness. Having this in mind and in need of a powerful approximate decomposition result, Kim, Kühn, Osthus and Tyomkyn [11] proved a far-reaching generalisation of the blow-up lemma, a ‘blow-up lemma for approximate decompositions’ stating that multipartite quasirandom graphs can be almost decomposed into any collection of bounded degree graphs with the same multipartite structure and slightly fewer edges. This tool can also be combined with the regularity lemma to obtain almost decompositions of graphs into bounded degree graphs, and it has been utilized in [9] and in [2] for a ‘bandwidth theorem for approximate decompositions’, which in turn is one of the key ingredients for the resolution of the Oberwolfach problem in [8]. Therefore, the blow-up lemma for approximate decompositions has already exhibited its versatility. However, its very complex and long proof is an obstacle for further generalisations. By using a similar approach as sketched in Section 2.1 and employing our more general version of Theorem 1, we present a new and significantly shorter proof [5] that even allows us to prove a more general version with stronger quasirandom properties.

References

- [1] N. Alon and R. Yuster, *On a hypergraph matching problem*, Graphs Combin. **21** (2005), 377–384.
- [2] P. Condon, J. Kim, D. Kühn, and D. Osthus, *A bandwidth theorem for approximate decompositions*, Proc. Lond. Math. Soc. (to appear).
- [3] S. Ehard, S. Glock, and F. Joos, *Pseudorandom hypergraph matchings*, arXiv:1907.09946 (2019).
- [4] S. Ehard, S. Glock, and F. Joos, *A rainbow blow-up lemma for almost optimally bounded edge-colourings*, arXiv:1907.09950 (2019).
- [5] S. Ehard and F. Joos, *A short proof for the blow-up lemma for approximate decompositions*, preprint (2019).
- [6] Z. Füredi, *Matchings and covers in hypergraphs*, Graphs Combin. **4** (1988), 115–206.
- [7] S. Glock and F. Joos, *A rainbow blow-up lemma*, arXiv:1802.07700 (2018).
- [8] S. Glock, F. Joos, J. Kim, D. Kühn, and D. Osthus, *Resolution of the Oberwolfach problem*, arXiv:1806.04644 (2018).
- [9] F. Joos, J. Kim, D. Kühn, and D. Osthus, *Optimal packings of bounded degree trees*, J. Eur. Math. Soc. (to appear).
- [10] J. Kahn, *A linear programming perspective on the Frankl-Rödl-Pippenger theorem*, Random Structures Algorithms **8** (1996), 149–157.
- [11] J. Kim, D. Kühn, D. Osthus, and M. Tyomkyn, *A blow-up lemma for approximate decompositions*, Trans. Amer. Math. Soc. **371** (2019), 4655–4742.
- [12] J. Komlós, G. N. Sárközy, and E. Szemerédi, *Blow-up lemma*, Combinatorica **17** (1997), 109–123.
- [13] R. Montgomery, A. Pokrovskiy, and B. Sudakov, *Embedding rainbow trees with applications to graph labelling and decomposition*, J. Eur. Math. Soc. (to appear).
- [14] N. Pippenger and J. Spencer, *Asymptotic behaviour of the chromatic index for hypergraphs*, J. Combin. Theory Ser. A **51** (1989), 24–42.

Parameterized complexity of edge-coloured and signed graph homomorphisms

Florent Foucaud², Hervé Hocquard¹, Dimitri Lajou¹, Valia Mitsou³, and Théo Pierron¹

¹ Univ. Bordeaux, Bordeaux INP, CNRS, LaBRI, UMR5800, F-33400 Talence, France

² Univ. Orléans, INSA Centre Val de Loire, LIFO EA 4022, F-45067 Orléans Cedex 2, France

³ Université Paris-Diderot, IRIF, CNRS, 75205, Paris, France

This research was financed by the ANR project HOSIGRA (ANR-17-CE40-0022) and the IFCAM project “Applications of graph homomorphisms” (MA/IFCAM/18/39)

EXTENDED ABSTRACT

The aim of this paper is to define and investigate some relevant parameterized variants of homomorphism problems for edge-coloured graphs.

A *t*-edge-coloured graph is a multigraph where each edge has a colour in $\{1, \dots, t\}$. A homomorphism f between two *t*-edge-coloured graphs G and H is a mapping from the vertices of G to the vertices of H such that, if x and y are joined by one edge of colour t in G , this also holds for $f(x)$ and $f(y)$ in H (see [2, 3]). If there exists such homomorphism, we write $G \xrightarrow{ec} H$. A core is a *t*-edge-coloured graph G such that if $G \xrightarrow{ec} H$ and H is a subgraph of G then H is isomorphic to G . A signed graph G is a 2-edge-coloured graph where we can switch at the vertices (usually the colours are signs). A switch at a vertex v consists in inverting the colours of the edges incident to v . A signed homomorphism is a homomorphism where we can arbitrarily switch at the vertices of the source graph. See Zaslavsky [11] for more on signed graphs, and Naserasr *et al.* [10] for studies on their signed homomorphisms. A signed core G is a signed graph such that any signed homomorphism from G to one of its subgraphs H implies that H is isomorphic to G (up to switching).

A parameterized problem is a decision problem together with a parameter of the input. Such problem is *fixed parameter tractable* (FPT) if for any input I with parameter value k can be solved in time $f(k)O(|I|^c)$ for some computable function f and integer c . It is XP if it can be solved in time $|I|^{g(k)}$ for some computable function g . For more details see [7].

Our inspiration comes from the following two popular parameterized *graph modification* problems. \mathcal{P} denotes a fixed graph property.

\mathcal{P} VERTEX-DELETION (RESP. EDGE-DELETION)	Parameter: k .
Input: A graph G , an integer k .	
Question: Is there a set S of at most k vertices (resp. edges) of G such that $G - S$ satisfies \mathcal{P} ?	

This class of problem contains some fundamental problems such as VERTEX COVER, FEEDBACK VERTEX/EDGE SET or ODD CYCLE TRANSVERSAL and EDGE BIPARTIZATION, that are all well-known to be NP-complete but FPT, see the book [7].

Given a fixed edge-coloured graph H , the classic *H*-COLOURING decision problem consists in determining, for an input graph G , whether $G \xrightarrow{ec} H$. (We can restrict ourselves to graphs H that are cores by replacing H with one of its subgraphs H' such that $H \xrightarrow{ec} H'$.) Similarly, the SIGNED *H*-COLOURING decision problem consists in determining whether there exists a signed homomorphism from a given 2-edge-coloured graph G to H . The complexity of these problems is studied for example in [2, 3] and [5, 6], respectively.

Since for many edge-coloured graphs H , *H*-COLOURING is polynomial-time solvable [2, 3, 4], it is of interest to refine this problem. We do this as follows (H is a fixed edge-coloured graph).

VD (RESP. ED) H -COLOURING	Parameter: k .
Input: An edge-coloured graph G , an integer k .	
Question: Is there a set S of at most k vertices (resp. edges) of G such that $(G - S) \xrightarrow{ec} H$?	

SW H -COLOURING	Parameter: k .
Input: A 2-edge-coloured graph G , an integer k .	
Question: Is there a set S of at most k vertices of G such that the 2-edge-coloured graph G' obtained from G by switching at every vertex of S satisfies $G' \xrightarrow{ec} H$?	

In this paper, we study the complexity of the three problems VD H -COLOURING, ED H -COLOURING and SW H -COLOURING. In Section 1, we make some preliminary observations in relation with the literature. In Section 2, we are able to completely classify the decision complexity of VD H -COLOURING. In Section 3, we address the case of edge-coloured graphs H of order 2, that are already nontrivial and interesting (see [1, 4]). We completely classify the parameterized complexity of VD H -COLOURING, ED H -COLOURING and SW H -COLOURING. Finally, we conclude in Section 4.

1 Preliminaries and known results

Whenever H -COLOURING is NP-complete, we deduce that VD H -COLOURING and ED H -COLOURING are NP-complete even for $k = 0$, and thus are not FPT for parameter k . For example this is the case when H is a monochromatic triangle. When SIGNED H -COLOURING is NP-complete, then SW H -COLOURING is NP-complete even for $k = |V(G)|$ (but could still be XP or FPT for k). On the other hand, if H -COLOURING is polynomial, then all three problems are in XP for parameter k :

Proposition 1 *Let H be an edge-coloured graph such that H -COLOURING is polynomial-time solvable. Then, the three problems can be solved in time $|G|^{O(k)}$.*

When $k = 0$ and H is 1-coloured, Hell and Nešetřil [8] proved that H -COLOURING is polynomial if the core of H has at most one edge (H is bipartite or has a loop), and NP-complete otherwise. As a consequence, for any edge-coloured graph H where one of the colours induces a graph with no loop and an odd cycle, then the non-parameterized versions of VD H -COLOURING, ED H -COLOURING and SW H -COLOURING are NP-complete even for $k = 0$, and thus, not FPT for parameter k , unless $P = NP$.

For the non-parameterized version of SW H -COLOURING with $k = |V(G)|$, (that is, SIGNED H -COLOURING), we have:

Theorem 2 (Brewster et al. [5, 6]) *Let H be a signed graph. SIGNED H -COLOURING is polynomial if the switching core of H has at most two edges, and NP-complete otherwise.*

Generally, not much is known about H -COLOURING for t -edge-coloured graphs. One notable result is the following.

Theorem 3 (Brewster et al. [4]) *Let H be a t -edge-coloured graph. H -COLOURING is polynomial by reduction to 2-SAT when H has order 2, or when H has order 3, is loop-free and contains no monochromatic triangle.*

2 NP-completeness of VD H -COLOURING

Lewis and Yannakakis defined a non-trivial property \mathcal{P} on graphs as a property true for infinitely many graphs and false for infinitely many graphs. A property \mathcal{P} is hereditary on induced subgraphs if and only if $\mathcal{P}(G)$ implies $\mathcal{P}(I)$ for I induced subgraph of G . They showed the following:

Theorem 4 (Lewis and Yannakakis [9]) *The \mathcal{P} VERTEX-DELETION problem for non-trivial graph-properties \mathcal{P} that are hereditary on induced subgraphs is NP-complete.*

By modifying their proof of the previous result, we can prove the two following results:

Theorem 5 *The \mathcal{P} VERTEX-DELETION problem for nontrivial properties \mathcal{P} , on loopless t -edge-coloured graphs, that are hereditary on induced subgraphs and true for all independent sets is NP-hard.*

Corollary 6 *The problem VD H -COLOURING for a t -edge-coloured graph H is polynomial if H contains a vertex having all t coloured loops and NP-complete otherwise.*

3 Graphs of order at most 2

It was proved in [1, 4] that for every edge-coloured graph H of order at most 2, H -COLOURING is polynomial-time solvable. In this section, we will refine this result by studying the three generalizations of H -COLOURING.

First of all, we describe in Figure 1 the twelve 2-edge-coloured graphs of order at most 2 that are cores, we consider these graphs up to symmetry of the two colours. We use the terminology of [1] to describe the graphs. We do not consider any 2-edge-coloured graph of order 2 with both kinds of loops since it would not be a core.

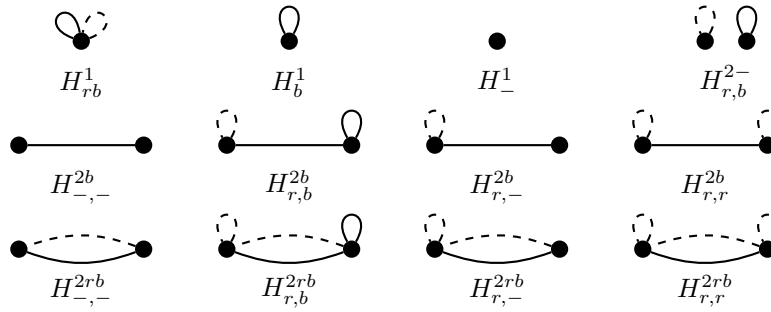

Figure 1: The twelve 2-edge-coloured graphs of order at most 2 considered in Section 3.

We classify here the complexity of the ED H -COLOURING problems according to the graph H . The VD H -COLOURING classification was done in Section 2.

Theorem 7 *Let H be an edge-coloured core of order at most 2. If each colour of H induces a set of loops or contains all three possible edges, then ED H -COLOURING lies in P , otherwise it is NP-complete.*

For many t -edge-coloured graphs H of order at most 2, we can show that VD H -COLOURING and ED H -COLOURING are FPT by giving ad-hoc reductions to VERTEX COVER, ODD CYCLE TRANSVERSAL or a combination of both. However, we can generalize the technique used for proving Theorem 3 by showing that all these problems can be expressed as an FPT variant of 2-SAT: VARIABLE DELETION ALMOST 2-SAT (see [7]) for VD H -COLOURING and a new variant that we call GROUP DELETION ALMOST 2-SAT for ED H -COLOURING.

Theorem 8 *For every edge-coloured graph H of order at most 2, VD H -COLOURING is FPT by reduction to VARIABLE DELETION ALMOST 2-SAT, and ED H -COLOURING is FPT by reduction to GROUP DELETION ALMOST 2-SAT.*

Note that for ED H -COLOURING, the same kind of argument gives a similar result for graphs of order 3 with no monochromatic triangle and no loop.

We now consider the SW H -COLOURING problem.

Theorem 9 *Let H be a 2-edge-coloured graph from Figure 1. If H is in $\{H_{r,b}^{2rb}, H_{r,-}^{2rb}, H_{r,r}^{2rb}\}$ the SW H -COLOURING is NP-complete and W[1]-hard. If H is in $\{H_{r,b}^{2b}, H_{r,-}^{2b}\}$, SW H -COLOURING is NP-complete but FPT. Otherwise, it is polynomial-time solvable.*

The W-hard cases are proved by a reduction to MULTICOLOURED INDEPENDENT SET and the FPT cases are resolved by a branching tree technique. The fact the SW H -COLOURING problem is harder than the other two comes from the fact that the switch operation does not remove constraints but moves them. It is thus not surprising to see W-hard problems here.

4 Conclusion and perspectives

In this paper, we introduced VD H -COLOURING, ED H -COLOURING and SW H -COLOURING and we characterized the complexity of the three problems for some small H . The full complexity landscape still needs to be determined.

Regarding their decision complexity, we have fully classified the VD H -COLOURING problems that are polynomial-time solvable. It remains to do the same for ED H -COLOURING and SW H -COLOURING.

References

- [1] Z. Bawar, R. C. Brewster and D. A. Marcotte. Homomorphism duality in edge-coloured graphs. **Annales des sciences mathématiques du Québec** 29(1):21–34, 2005.
- [2] R. C. Brewster. Vertex colourings of edge-coloured graphs. **PhD thesis**, Simon Fraser University, Canada, 1993.
- [3] R. C. Brewster. The complexity of colouring symmetric relational systems. **Discrete Applied Mathematics** 49(1–3):95–105, 1994.
- [4] R. C. Brewster, R. Dedić, F. Huard and J. Queen. The recognition of bound quivers using edge-coloured homomorphisms. **Discrete Mathematics** 297:13–25, 2005.
- [5] R. C. Brewster, F. Foucaud, P. Hell and R. Naserasr. The complexity of signed and edge-coloured graph homomorphisms. **Discrete Mathematics** 340(2):223–235, 2017.
- [6] R. C. Brewster and M. H. Siggers. A complexity dichotomy for signed H -colouring. **Discrete Mathematics** 341(10):2768–2773, 2018.
- [7] M. Cygan, F. V. Fomin, L. Kowalik, D. Lokshtanov, D. Márx, M. Pilipczuk, M. Pilipczuk and S. Saurabh. Parameterized Algorithms. Springer Publishing Company, 2015.
- [8] P. Hell and J. Nešetřil. On the complexity of H -coloring. **Journal of Combinatorial Theory Series B** 48(1), 92–110, 1990.
- [9] J. M. Lewis and M. Yannakakis. The node-deletion problem for hereditary properties is NP-complete. **Journal of Computer and System Sciences** 20(2):219–230, 1980.
- [10] R. Naserasr, E. Rollová and É. Sopena. Homomorphisms of signed graphs. **Journal of Graph Theory** 79(3):178–212, 2015.
- [11] T. Zaslavsky. Signed Graphs. **Discrete Applied Mathematics** 4(1):47–74, 1982.

Asymptotic growth rate of square grids dominating sets: a symbolic dynamics approach

Silvère Gangloff and Alexandre Talon

ENSL, Univ Lyon, UCBL, LIP, MC2, F-69342, LYON Cedex 07, France

EXTENDED ABSTRACT

A series of works has been done on the combinatorics of dominating sets of graphs, that is sets of vertices such that any vertex of the graph is neighbour of a vertex in this set, and some variants, including notably minimal dominating sets. For instance, what is the minimal cardinality of a dominating set of a graph? This question was answered for finite square grids in [1]. We follow this stream by studying the number of dominating sets for finite square grids. Although it is very hard to have a closed formula for this number, one can have some information on its asymptotic behaviour. In particular, we prove the existence of an asymptotic growth rate by giving enclosing it between quantities related to a symbolic dynamical system (called subshift of finite type), whose asymptotic behaviour is related to the entropy of the system. Moreover, using some properties of this dynamical system, we prove that the growth rate is a computable number, meaning that it can be approximated by an algorithm. We then obtain some bounds by running a program. All this is also done for other variations of the notion of dominating set: minimal dominating, total dominating and minimal total dominating sets.

Some definitions. A **regular dominating set** S of a graph G is a subset of its vertices such that any vertex not in S is connected to a vertex in S . A **minimal dominating set** is a dominating set which is inclusionwise minimal: for any $v \in S$, $S \setminus \{v\}$ is not dominating. A **total dominating set** S is a subset of vertices such that any vertex v in G is connected to a vertex in S . When $v \in S$ is the neighbour of some w we say that w is **dominated** by v . Any element of S is called **dominant**. If a vertex v is dominated by a single $w \in S$ then we say that v is a **private neighbour** of w . A dominant vertex is isolated n and height m . The notions of dominating sets are illustrated on Figure 1.

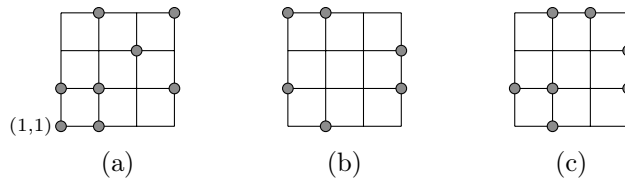

Figure 1: Illustration of grids and some domination concepts on $G_{4,4}$:

- (a) a dominating set which is neither minimal dominating nor total dominating;
- (b) a minimal dominating set which is not total dominating (the bottom-left dominant vertices are not dominated);
- (c) a minimal total dominating set.

In this abstract, we focus on regular dominating sets (other domination notions have similar statements). We denote by $D_{n,m}$ the number of dominating sets of the grid $G_{n,m}$. Our aim is to evaluate the asymptotic behaviour of these numbers when $n, m \rightarrow +\infty$.

From dominating sets to symbolic dynamical systems. In order to check if a set of vertices of a square grid is dominating (for any notion of domination), one can look at the neighbours of each vertex to check that the vertex, if not dominant, is dominated. This notion of locality is the main ingredient of the definition of subshift of finite type, a particular type of dynamical system. Informally, given a finite set of colours \mathcal{A} , a bidimensional SFT is the set of colourings of \mathbb{Z}^2 with elements of \mathcal{A} avoiding all the patterns in \mathcal{F} , where \mathcal{F} is a finite

set of finite patterns (formally, a finite pattern is an element of $\mathcal{A}^{\mathbb{U}}$ for \mathbb{U} a finite subset of \mathbb{Z}^2). Formally:

$$X = \left\{ x \in \mathcal{A}^{\mathbb{Z}^d} : \forall \mathbf{u} \in \mathbb{Z}, x|_{\mathbf{u}+\mathbb{U}} \notin \mathcal{F} \right\}.$$

The elements of \mathcal{F} are called **forbidden patterns**.

One can see a regular dominating set S of the infinite grid \mathbb{Z}^2 as a colouring of the grid with two colours, say gray and white, by colouring the elements of S with gray and the other vertices with white. The local rules for a set S to be a dominating set can be seen as forbidden patterns, and the set of dominating sets is a subshift of finite type, denoted by X^D .

Existence of asymptotic growth rates using topological entropy. Let us denote by $N_{n,m}(X^D)$ the number of patterns on the grid $G_{n,m}$ which do not contain any forbidden pattern for X^D . One important property of this sequence is that $\frac{\log_2(N_{n,m}(X^D))}{nm}$ converges when n and m tend towards $+\infty$. The limit is called the **topological entropy** of X^D (this quantity can be defined for any dynamical system). Let us just notice that $N_{n,m}(X^D)$ is not equal to $D_{n,m}$, due to border effects in the definition of dominating set.

In order to prove the existence of an asymptotic growth rate for $D_{n,m}$, meaning that the sequence $\log_2(D_{n,m})/nm$ converges, we enclose it between $N_{n,m}(X^D)$ and $N_{n-1,m-1}(X^D)$. The arguments involved in the proof of this comparison are few-to-one transformations of dominating sets of the finite grids to patterns of X^D and reciprocally. Moreover, the growth rate (the limit of $\log_2(D_{n,m})/nm$) is equal to the topological entropy of X^D .

Computability of the growth rate. It is known that in general the entropy of a subshift of finite type is not computable [3], in the sense that there are no algorithms which would provide a rational approximation of it given an arbitrary precision as input. However, we proved that the SFT X^D satisfies a strong dynamical property called **block-gluing**. This means that there exists some integer c such that any pair of patterns appearing in a colouring of X^D can be glued in any relative positions in another colouring of X^D , provided that the distance between the patterns is greater than c . This implies that the entropy of X^D is computable, and an explicit algorithm is known to compute its entropy [4].

Some bounds obtained with a program. One can compute the sequence $N_{n,m}(X^D)$ algorithmically by checking for any possible pattern if it contains a forbidden pattern or not. However, one can do a bit more efficient by using the notion of **transfer matrix**, an object which describes which pairs of finite columns patterns (with the same height) can be adjacent without breaking the rules of the SFT. If we denote by V_m the transfer matrix for height m , one can see that $\log_2(N_{n,m})/n$ converges towards the greatest eigenvalue of V_m . Since V_m a Perron-Frobenius matrix (due to properties of symmetry of X^D), we can use an algorithm to compute the Perron Frobenius of the matrices V_m in order to obtain approximations of the growth rate. We use this to provide some numerical bounds.

References

- [1] D. Gonçalves, A. Pinlou, M. Rao and S. Thomassé. The domination number of grids. *SIAM Journal on Discrete Mathematics* 25.3 (2011): 1443-1453.
- [2] I. Heinrich and P. Tittmann. Counting Dominating Sets of Graphs. arXiv, 2017
- [3] M. Hochman and T. Meyerovitch. A characterization of entropies of multidimensional subshifts of finite type. *Annals of mathematics*, 2011.
- [4] R. Pavlov and M. Schraudner. Entropies realizable by block gluing \mathbb{Z}^d subshifts of finite type. *Journal D'analyse mathématique*, 2015.

- [5] D. Lind and B. Marcus. An Introduction to Symbolic Dynamics and Coding. Cambridge university press, 1995.
- [6] Michaël Rao and Alexandre Talon. The 2-domination and Roman domination numbers of grid graphs Discrete Mathematics & Theoretical Computer Science 25.1 (2019).

Packing colorings of subcubic outerplanar graphs

Boštjan Brešar¹, Nicolas Gastineau², and Olivier Togni²

¹ Faculty of Natural Sciences and Mathematics, University of Maribor, Slovenia
Institute of Mathematics, Physics and Mechanics, Ljubljana, Slovenia

² Laboratoire d'Informatique de Bourgogne (LIB), Université de Bourgogne Franche-Comté,
France

EXTENDED ABSTRACT

Given a graph G and a nondecreasing sequence $S = (s_1, \dots, s_k)$ of positive integers, the mapping $c : V(G) \rightarrow \{1, \dots, k\}$ is called an S -packing coloring of G if for any two distinct vertices x and y in $c^{-1}(i)$, the distance between x and y is greater than s_i . The smallest integer k such that there exists a $(1, 2, \dots, k)$ -packing coloring of a graph G is called the packing chromatic number of G , denoted $\chi_\rho(G)$.

One of the main questions since the problem was introduced a decade ago [6] is concerning graphs with bounded maximum degree Δ , in particular, *subcubic graphs* (i.e., graphs with $\Delta = 3$). For graphs with maximum degree Δ , where $\Delta \geq 4$, already the infinite Δ -regular tree serves as an example showing that in this class of graphs the packing chromatic number is unbounded. On the other hand, the question whether in subcubic graphs the packing chromatic number is bounded was much more intriguing. Recently, Balogh, Kostochka and Liu [1] have provided a negative answer to the question. Moreover, they proved that for every fixed k and $g \geq 2k + 2$, almost every n -vertex cubic graph of girth at least g has the packing chromatic number greater than k . An explicit infinite family of subcubic graphs with unbounded packing chromatic number was then presented in [3].

As the question was answered in negative for all graphs with bounded maximum degree 3, it becomes interesting for some subclasses of subcubic graphs. In particular, already in [4] it was asked, whether there is an upper bound for the packing chromatic number of all planar cubic graphs, and this question was repeated in [3]. Very recently, packing chromatic number of subcubic outerplanar graphs was considered [5]. The upper bounds obtained in the paper involve the number of (internal) faces of the plane embedding of an outerplanar graph; for instance, it is proven that if G is a 2-connected subcubic outerplanar graph with r internal faces, then $\chi_\rho(G) \leq 17 \cdot 6^{3r} - 2$. The question of boundedness of the packing chromatic number in subcubic outerplanar graphs thus seems widely open. In this paper, we prove that, quite surprisingly, only 7 colors suffice if we restrict to bipartite 2-connected case:

Theorem 1. *Let G be a 2-connected bipartite subcubic outerplanar graph. Then $\chi_\rho(G) \leq 7$.*

Proof. (sketch of) The general idea of the proof is to use the tree structure of the weak dual of G to color every but one (adequately chosen) vertex of each face, using first the colors 1, 2, 3. The remaining uncolored vertices, called the *big vertices* are then colored using colors from $\{4, 5, 6, 7\}$. In order to do this, we prove at each step that the obtained coloring $f : V(G) \rightarrow \{1, \dots, 7\}$ satisfies the following four properties:

- (i) Any vertex with color from $\{2, \dots, 7\}$ has all its neighbors colored by color 1.
- (ii) Any face α of G contains exactly one big vertex if $|V(\alpha)| \geq 6$ and at most one big vertex if $|V(\alpha)| = 4$.
- (iii) Any big vertex is at distance at least 4 of any other big vertex.
- (iv) Any vertex with color from $\{6, 7\}$ is at distance at least 6 of any vertex of color from $\{6, 7\}$.

Depending on the position of the big vertex of a face ω , the big vertex of each face α that is a child of ω in a BFS ordering of the weak dual will be chosen (by considering three cases

depending on the distance between the big vertex of ω and the face α). Now, in order to color the big vertices, a step is to consider the face α and to color all the uncolored big vertices at distance at most two of α . We need to consider three cases depending on the position of the big vertex and the corresponding coloring of α .

For instance, one of the three configurations is illustrated in Figure 1, where u is the big vertex of face α . Then, depending on the colors of u, r and s , we present in each case a pattern to color the remaining big vertices. For example, if $f(u) = 4$ and $\{f(r), f(s)\} = \{5, 7\}$, then we color the big vertices starting from the one of β_1 and going around the face α with one of these patterns, depending on the length n of α (where numbers between vertical bars are to be repeated k times):

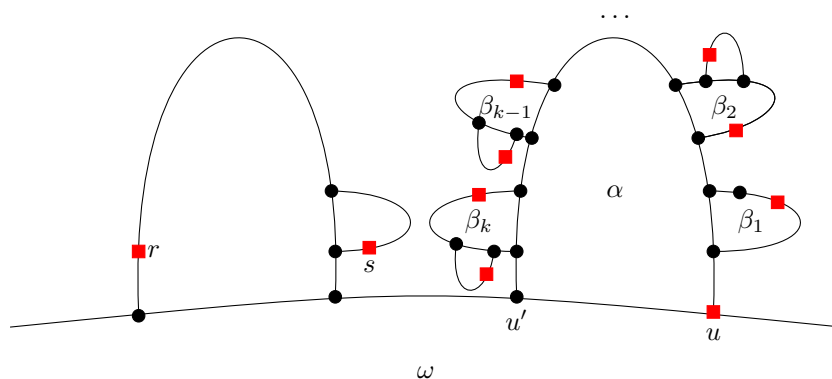

Figure 1: Configuration for the big vertices (red boxes) for the case the big vertex u of α is at the intersection with face ω .

$$\text{Pattern for length } n = 4k + 8: \quad \begin{array}{cccc|cccc} 7 & & & 6 & & 7 & & 4 & & 5 \\ & 5 & & & 4 & & 5 & & & 6 \end{array}$$

$$\text{Pattern for length } n = 8k + 6: \quad \begin{array}{cccc|cccc|c} 5 & & & 5 & & 5 & & 5 & & 5 & & 5 \\ & 6 & & & 4 & & 7 & & 4 & & 6 & & \end{array}$$

Pattern for length $n = 8k + 10$:

$$\begin{array}{cccc|cccc|c} 5 & & 5 & & 5 & & 5 & & 5 & & 5 \\ & 7 & & 4 & & 6 & & 4 & & 7 & & 4 & & 6 & & \end{array}$$

□

The following proposition shows that the above theorem is sharp in general:

Proposition 2. *There exists a 2-connected bipartite subcubic outerplanar graph G such that $\chi_\rho(G) \geq 7$.*

Proof. Let \mathcal{T} be the infinite binary tree. Sloper [7] has proven that $\chi_\rho(\mathcal{T}) = 7$. A consequence is that there exists a finite subcubic tree T such that $\chi_\rho(T) = 7$. Let d be the depth of T . Finally, let $k = 2d + 2$.

Let x and y be two adjacent vertices of degree 2 in a graph G . Adding a k -cycle on x and y is an operation that consists of adding a path of $k - 2$ vertices to G and joining one endvertex of the path to x and the other endvertex to y . Let G_1 be a cycle of order k . Let G_{i+1} , $i \geq 1$, be the graph obtained from G_i by adding a k -cycle on every adjacent pair of vertices of degree 2 in G_i , where we arrange these pairs in such a way that each vertex of degree 2 belongs to one adjacent pair; this can be done by adding k -cycles on adjacent vertices

of degree 2 following the outer cycle of G_i . In this way, in G_{i+1} there does not remain any vertex of degree 2 from $V(G_i)$. Note that, by construction, G_i is a 2-connected bipartite subcubic outerplanar graph for every integer $i \geq 1$.

Let u be a vertex that belongs to G_1 in the construction of G_k . Note that the set $\{v \in V(G_k) \mid d(u, v) \leq d\}$ induces a subcubic tree containing T as an induced subgraph. Thus, since every graph has a packing chromatic number larger or equal than the packing chromatic number of any of its (induced) subgraphs, we derive $\chi_\rho(G_k) \geq 7$. \square

We now present a result about bipartite outerplanar graphs (i.e., no restriction to 2-connectedness and arbitrary maximum degree).

Theorem 3. *Let G be a bipartite outerplanar graph. Let $S = (1, 3, \dots, 3)$ be the sequence containing one time the integer 1 and k times the integer 3, $k \geq 3$. If $\Delta(G) \leq k$, then G is S -packing colorable.*

It can be observed that a $(k-1)$ -ary tree of height (at least) five is not $S = (1, 3, \dots, 3, 4)$ -packing colorable, where 3 appears $k-1$ times in S , showing the sharpness of the above result.

For the non-bipartite case we are able to prove:

Theorem 4. *If G is a subcubic triangle-free outerplanar graph, then G is $(1, 2, 2, 2)$ -packing colorable.*

Again, this result is sharp since there exist counter examples both if the graph is not triangle-free or if an integer 2 is replaced by 3 in the sequence.

We finish by proposing two problems that lie between Theorem 1 and the question of boundedness of the packing chromatic number in the class of planar subcubic graphs posed in several papers. In one of them, we consider non-bipartite extension of the theorem, and in the other we replace outerplanar graphs by planar graphs.

Question 5. *Is the packing chromatic number bounded in the class of 2-connected outerplanar subcubic graphs?*

Question 6. *Is the packing chromatic number bounded in the class of 2-connected bipartite planar subcubic graphs?*

We strongly believe that Theorem 1 could be extended from the 2-connected case to all bipartite outerplanar subcubic graphs.

References

- [1] J. Balogh, A. Kostochka, X. Liu, Packing chromatic number of subcubic graphs, *Discrete Math.* 341 (2018) 474–483.
- [2] J. Balogh, A. Kostochka, X. Liu, Packing chromatic number of subdivisions of cubic graphs, *Graphs and Combinatorics* 35 (2019) 513–537.
- [3] B. Brešar, J. Ferme, An infinite family of subcubic graphs with unbounded packing chromatic number, *Discrete Math.* 341 (2018) 2337–2342.
- [4] J. Fiala, S. Klavžar, B. Lidický, The packing chromatic number of infinite product graphs, *European J. Combin.* 30 (2009) 1101–1113.
- [5] N. Gastineau, P. Holub, O. Togni, On packing chromatic number of subcubic outerplanar graphs, *Discrete Appl. Math.* 255 (2019) 209–221.
- [6] W. Goddard, S.M. Hedetniemi, S.T. Hedetniemi, J.M. Harris, D.F. Rall, Broadcast chromatic numbers of graphs, *Ars Combin.* 86 (2008) 33–49.
- [7] C. Sloper, An eccentric coloring of trees, *Austral. J. Combin.* 29 (2004) 309–321.

Monochromatically-connecting colorings of strong digraphs

Diego González-Moreno¹, Mucuy-kak Guevara² and Juan José Montellano-Ballesteros³,

¹ Departamento de Matemáticas Aplicadas y Sistemas, Universidad Autónoma Metropolitana - Cuajimalpa, México

² Facultad de Ciencias, Universidad Nacional Autónoma de México

³ Instituto de Matemáticas, Universidad Nacional Autónoma de México

EXTENDED ABSTRACT

Let D be a strong digraph. A vertex coloring of D is a *strong vertex-monochromatically connecting coloring* (SVMC-coloring, for short) if for every pair u, v of distinct vertices in D , there exists a (u, v) -path and a (v, u) -path having all the internal vertices of the same color. Let $smc_v(D)$ denote the maximum number of colors used in an SVMC-coloring of a strong digraph D . In this work we present lower and upper bounds for $smc_v(D)$ of a strong digraph D . We determine the value of $smc_v(D)$, when D is the line digraph of a digraph. Finally, if T is a strong tournament, we give conditions to find the exact value of $smc_v(T)$.

INTRODUCTION

In 2011, Caro and Yuster [1] introduced the concept of monochromatically-connecting coloring of a graph. An edge-coloring of a graph is a *monochromatically-connecting coloring* (MC-coloring, for short) if there exists a monochromatic path joining any two vertices of the graph. The study of monochromatically-connecting colorings arises from the rainbow connecting coloring problem, in which rainbow paths are considered (a path is *rainbow* if no two edges of them are colored the same).

The monochromatically-connecting colorings can be naturally extended to digraphs. An arc-coloring of a digraph D is a *strong monochromatically-connecting coloring* (SMC-coloring, for short) if for every $u, v \in V(D)$ there exist an (u, v) -monochromatic path and a (v, u) -monochromatic path. The *strong monochromatic connection number* of a strong digraph D , denoted by $smc(D)$, is the maximum number of colors used in an SMC-coloring of D .

Given a strong digraph D and a strong spanning subdigraph H of D , by coloring the arcs of H with one single color and the remaining arcs with distinct colors, an SMC-coloring of D with $m - |A(H)| + 1$ colors is obtained. If $\Omega(D)$ denotes the minimum size of a strong connected spanning subdigraph of D , then $smc(D) \geq m - \Omega(D) + 1$. In fact, the equality always holds.

Theorem 1 (González-Moreno, Guevara, Montellano-Ballesteros '17 [3]) *Let D be a strong oriented graph of size m , and let $\Omega(D)$ be the minimum size of a strong spanning subdigraph of D . Then*

$$smc(D) = m - \Omega(D) + 1.$$

Corollary 2 *Let D be a strongly connected oriented graph of size m and order n . Then D is hamiltonian if and only if $smc(D) = m - n + 1$.*

Notice that from Corollary 2, we can see also that computing $\Omega(D)$ is NP-hard.

Cai, Li and Wu [6] defined the vertex version of MC-colorings. This concept also can be extended to digraphs. A directed path in a vertex-colored digraph is *vertex-monochromatic* if its internal vertices are colored the same. A vertex-coloring of a digraph D is a *strong vertex-monochromatically connecting coloring* (SVMC-coloring, for short) if for every $u, v \in V(D)$ there exist a directed (u, v) -vertex-monochromatic path and a directed (v, u) -vertex-monochromatic path. The *vertex-monochromatic connection number* of a strong digraph D , denoted by $smc_v(D)$, is the maximum number of colors that can be used in a SMVC-coloring of D .

For a general overview of the monochromatic and rainbow connection subjects we refer the reader to [2, 4, 5].

VERTEX-MONOCROMATIC CONNECTING COLORINGS IN STRONG DIGRAPHS

A set $S \subseteq V(D)$ is *absorbing* (*dominating*) if for each vertex $v \in V(D) \setminus S$ there exists a vertex $u \in S$ such that $v \in N^-(u)$ ($v \in N^+(u)$). Let D be a strong digraph and let H be a strong subdigraph of D such that $V(H)$ is an absorbing and dominating set of D . By coloring the vertices of H with one single color and the remaining vertices with distinct colors, an SVMC-coloring of D with $n - |V(H)| + 1$ colors is obtained. Let $\Omega_v(D)$ denote the minimum order of a strong subdigraph H of D such that $V(H)$ is absorbing and dominating. Therefore

$$smc_v(D) \geq n - \Omega_v(D) + 1. \quad (1)$$

The proof of the following proposition is straightforward and is the digraph version of the bounds obtained by Cai, Li and Wu [6] for the vertex-monochromatic connection number of a graph.

Proposition 3 *Let D be a strong digraph of order n and diameter d . Then*

- i) $smc_v(D) = n$ if and only if $d \leq 2$.
- ii) If $d \geq 3$, then $smc_v(D) \leq n - d + 2$.

Let D be the digraph with vertex set $V(D) = \{v_1, v_2, \dots, v_n\}$ and arc set $A(D) = \{v_1v_2\} \cup \{v_2v_i, v_iv_1 \mid i \in \{3, 4, \dots, n\}\}$ (see Figure 1). Observe that $\Omega_v(D) = 3$, $diam(D) = 3$ and $smc_v(D) = n - diam(D) + 2 = n - 1 > n - \Omega_v(D) + 1$.

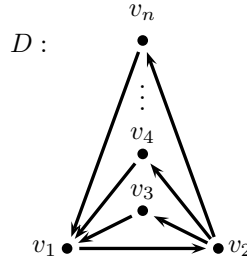

Figure 1: Digraph D with $smc_v(D) = n - diam(D) + 2$.

Lemma 4 *Let D be a strong digraph and let Γ be an SVMC-coloring of D . Let S be the set of singular chromatic classes of Γ and let D^* be the digraph induced by $V(D) \setminus S$.*

- i) *If for every vertex v of D there exists a vertex x such that $d(v, x) \geq 3$, then $V(D^*)$ is an absorbing set of D .*
- ii) *If for every vertex v of D there exists a vertex x such that $d(x, v) \geq 3$, then $V(D^*)$ is a dominating set of D .*
- iii) *If $g(D) \geq 5$, then $V(D^*)$ is strong, absorbing and dominating set of D .*

Theorem 5 *Let D be a strong digraph of order n and girth $g \geq 5$. Let Γ be an SVMC-coloring of D that uses $smc_v(D)$ colors. If ℓ is the minimum cardinality of a non-singular chromatic class of Γ , then*

$$n - \Omega_v(D) + 1 \leq smc_v(D) \leq n - \Omega_v(D) + \frac{\Omega_v(D)}{\ell}.$$

Corollary 6 *Let D be a strong digraph of order n . Then*

$$n - \Omega_v(D) + 1 \leq smc_v(D) \leq n - \frac{\Omega_v(D)}{2}.$$

We continue studying the vertex-monochromatic connection number of line digraphs. Recall that the *line digraph* $L(D)$ of a digraph $D = (V, A)$ has A for its vertex set and ef is an arc of $L(D)$ if the head of e coincides with the tail of f . A digraph H is called a *line digraph* if there exists a digraph D such that $L(D)$ is isomorphic to H .

We need some previous results before determining the value of $smc_v(D)$ for a line digraph D .

Proposition 7 *Let D be a strong digraph and let H be a spanning and strong subdigraph of D . If $L(H)$ is the subdigraph of $L(D)$ induced by the arcs of H , then $L(H)$ is a strong subdigraph and $V(L(H))$ is an absorbing and dominating set of $L(D)$.*

Let H be a spanning and strong subdigraph of a strong digraph D with $|E(H)| = \Omega(D)$. By the above proposition, there is an SVMC-coloring of $L(D)$ with $|V(L(D))| - |V(L(H))| + 1 = m - \Omega(D) + 1 = smc(D)$ colors. Hence,

$$smc_v(L(D)) \geq smc(D).$$

An ordered pair (u, v) of vertices of a strong digraph D is said to be a *bad pair* if $N^+(u) = \{v\}$ and $N^-(v) = \{u\}$. Observe that if (u, v) is a bad pair, then uv is an arc of D and the pair (v, u) is not a bad pair.

Lemma 8 *Let D be a strong digraph and let $H = L(D)$. Let Γ be an SVMC-coloring of H and let Γ' be the arc-coloring of D that assigns to each arc $e \in A(D)$ the color $\Gamma(e)$ of the vertex $e \in V(H)$. Given two vertices u and v in D there exists an (v, u) -edge-monochromatic path in D if one of the following conditions holds.*

- i) The ordered pair (u, v) is not a bad pair.*
- ii) The ordered pair (u, v) is a bad pair and there exists an arc vw in D such that (v, w) is not a bad pair.*
- iii) The ordered pair (u, v) is a bad pair and there exists an arc wu in D such that (w, u) is not a bad pair.*
- iv) If the previous cases do not happen and D is different from C_3 .*

Theorem 9 *Let D be a strong directed graph different from the cycle of length 3. Then*

$$scm_v(L(D)) = smc(D).$$

Notice that $L(C_3) \cong C_3$, $smc_v(C_3) = 3$ and $smc(C_3) = 1$.

Finally, a condition on $\Omega_v(T)$ of a strong tournament T is given in order to find the exact value of $smc_v(T)$.

Theorem 10 *Let T be a strong tournament of diameter $d \geq 6$. If $\Omega_v(T) \leq 2d - 6$, then*

$$smc_v(T) = n - \Omega_v(T) + 1.$$

References

- [1] Y. Caro, R. Yuster Colorful monochromatic connectivity. In **Discrete Math.** 311:1786–1792, 2011.
- [2] G. Chartrand, G. L. Johns, K. A. McKeon, P. Zhang, Rainbow connection in graphs, In **Math. Bohem.** 133:85–98, 2008.
- [3] D. González-Moreno, M. Guevara M, J. J. Montellano-Ballesteros Monochromatic connecting colorings in strongly connected oriented graphs. In **Discrete Math.** 340:578–584, 2017.
- [4] X. Li, Y. Sun, Rainbow Connections of Graphs. Springer, London, (2013).
- [5] X. Li, D. Wu, D. A Survey on Monochromatic Connections of Graphs In **Theory and Applications of Graphs 0**: Iss. 1, Art. 4, 2018.
- [6] C. Qingqiong, L. Xueliang, W. Di. Some extremal results on the colorful monochromatic vertex-connectivity of a graph. In **J. Comb. Optim.** 35:1300–1311, 2018.

Self contained graphs and twin graph conjectures

Geña Hahn

DIRO, Université de Montréal

EXTENDED ABSTRACT

A graph G is *embedded* in a graph H if there exists an *embedding* of G into H , that is, an injection $e : V(G) \rightarrow V(H)$ that is not surjective and whose image induces a graph isomorphic to G . Note that our definition requires that the two graphs be non-isomorphic; this eliminates trivialities from the discussion. A graph is *self-contained*¹ if G embeds into itself. Such graphs are necessarily infinite. Two non-isomorphic graphs are *twins* (called *equimorphic* in [4]) if each embeds in the other. Clearly if G and H are twins then each is self-contained.

It has been conjectured by Bonato and Tardif in [2] that a tree has zero either infinitely many twins. This has been proved for rooted trees [7] and for scattered trees [4]. In general, there are several conjectures that can be made.

Conjecture 1 *If a graph has a twin, it has infinitely many.*

Conjecture 2 *If a connected graph has a twin, it has infinitely many.*

Conjecture 3 *If a connected graphs has a connected twin, it has infinitely many.*

Conjecture 4 *Conjectures 1 and 3 are equivalent*

Conjecture 5 *Conjectures 1 and 2 are equivalent*

The authors of [5] attempted to prove Conjecture 4. Unfortunately, the main lemma in the paper is false. It concerns the structure of self-contained graphs. The paper is our starting point. We prove a correct version of the lemma and, using it, prove Conjecture 5. Of course, Conjecture 5 has a much simpler proof, but our structural lemma allows us to show that if a disconnected graph has infinitely many twins, it has at least 2^{\aleph_0} of them. The results lead to a proof of Conjecture 1 for several classes of graphs.

Work in progress in collaboration with Julien Codsì, Alizée Gagnon and Robert Woodrow.

References

- [1] A. Bonato, H. Bruhn, R. Diestel, P. Sprüssel, Twins of rayless graphs, *J. Comb. Th. (Ser. B)* **101** (2011), 60-65
- [2] A. Bonato, C. Tardif, Mutually embeddable graphs and the Tree Alternative conjecture, *J. Comb. Th. (Ser. B)* **96** (2006), 874-880.
- [3] A. Bonato, C. Tardif, Large families of mutually embeddable vertex-transitive graphs, *J. Graph Th.* **43** (2003), 99-106.
- [4] C. Laflamme, M. Pouzet, N. Sauer, Invariant subsets of scattered trees. An application to the tree alternative property of Bonato and Tardif, *arXiv:1508.01123v2* (2016)
- [5] M. H. Shekarriz1 and M. Mirzavaziri, Self-contained graphs, *arXiv:1503.00139v2* (2016).
- [6] M. H. Shekarriz1 and M. Mirzavaziri, Strong Twins of Ordinary Star-Like Self-Contained Graphs, *arxiv:1503:00179v3* (2015)
- [7] M. Tyomkyn, A proof of the rooted tree alternative conjecture, *Discrete Math.* **309** (2009), 5963-5967.

¹Any suggestion of a better name is most welcome. Possible *self-embedded*?

Resolving Sets of Vertices in Flower Snarks

*Anni Hakanen*¹, *Ville Junnila*¹, *Tero Laihonen*¹, and *María Luz Puertas*²

¹ Department of Mathematics and Statistics, University of Turku, Finland

² Department of Mathematics, Universidad de Almería, Spain

EXTENDED ABSTRACT

Let G be a finite, connected, simple and undirected graph with vertices V and edges E . Consider a vertex set $S = \{s_1, s_2, \dots, s_k\}$. We define the *distance array* of $v \in V$ with respect to S as $\mathcal{D}_S(v) = (d(s_1, v), d(s_2, v), \dots, d(s_k, v))$. If each vertex of G has a unique distance array with respect to S , then S is a *resolving set* of G . The smallest cardinality of a resolving set of G is called the *metric dimension* of G and it is denoted by $\beta(G)$. Resolving sets were first introduced by Slater [7] and Harary and Melter [3], independently. This concept is now widely studied and many variants have been introduced.

One quite recent concept is the $\{\ell\}$ -resolving set of a graph, which was introduced in [6]. Instead of individual vertices, we now consider sets of vertices with at most ℓ elements. To that end, we define the distance array of a vertex set X with respect to S as $\mathcal{D}_S(X) = (d(s_1, X), \dots, d(s_k, X))$, where $d(s_i, X) = \min\{d(s_i, x) \mid x \in X\}$.

Definition 1 *If each non-empty vertex set X with at most ℓ elements has a unique distance array with respect to S , then S is an $\{\ell\}$ -resolving set of G . The smallest cardinality of an $\{\ell\}$ -resolving set of G is called the $\{\ell\}$ -metric dimension of G and it is denoted by $\beta_\ell(G)$.*

When $\ell = 1$, this definition is equivalent with the definition of the regular resolving set.

Resolving sets can be used to locate objects in sensor networks. Consider for example a network where we locate faulty processors with a regular resolving set. If there are two or more faulty processors simultaneously, the distance array given by the resolving set might correspond to some vertex which does not represent a faulty processor. Now we end up trying to repair a processor which is functioning correctly. To avoid this type of situation, *solid-resolving sets* were introduced in [1]. A vertex set is a solid-resolving set, if each vertex has a unique distance array and no vertex set with two or more vertices has the same distance array as any one vertex. The following definition generalises this concept.

Definition 2 *Let X and Y be non-empty vertex sets such that $X \neq Y$ and $|X| \leq \ell$. If S is a vertex set such that $\mathcal{D}_S(X) \neq \mathcal{D}_S(Y)$ for all X and Y , then S is called an ℓ -solid-resolving set. The smallest cardinality of an ℓ -solid-resolving set of G is called the ℓ -solid-metric dimension of G and it is denoted by $\beta_\ell^s(G)$.*

In general, determining the metric dimension of a graph is difficult. In [5], it was shown that determining the regular metric dimension of an arbitrary graph is NP-complete. Similar results can be shown for the ℓ -solid- and $\{\ell\}$ -metric dimensions of an arbitrary graph.

Theorem 3 *If G is a graph and k is an integer, then deciding whether the $\{\ell\}$ -metric dimension $\beta_\ell(G) \leq k$ is an NP-complete problem. Similarly, deciding whether the ℓ -solid-metric dimension $\beta_\ell^s(G) \leq k$ is an NP-complete problem.*

However, if ℓ is large enough compared to the number of vertices of the graph, the decision problem for the $\{\ell\}$ -metric dimension becomes algorithmically easy since $\beta_\ell(G) = |V|$ by the following theorem.

Theorem 4 *Let G be a connected graph such that the minimum degree $\delta(G) \geq 2$. If $\ell \geq (|V| - 1)/2 + 1$, then we have $\beta_\ell(G) = |V|$.*

1 General Results

In what follows, we will state without proofs some of our new results regarding $\{\ell\}$ -resolving sets and ℓ -solid-resolving sets. The characterisation of the following theorem makes finding ℓ -solid-resolving sets of a graph easier. Indeed, compared to Definition 2 we need to make significantly fewer comparisons between distance arrays of distinct sets. Furthermore, the following theorem gives us a way to consider ℓ -solid-resolving sets in graphs via the structure of the graph and not the distance arrays.

Theorem 5 *Let $S \subseteq V$ and $\ell \geq 1$. The set S is an ℓ -solid-resolving set of G if and only if for all $x \in V$ and nonempty $Y \subseteq V$ such that $x \notin Y$ and $|Y| \leq \ell$, there exists an element $s \in S$ such that*

$$d(s, x) < d(s, Y). \quad (1)$$

Theorem 6 *Let $S \subseteq V$ and $\ell \geq 1$.*

- (i) *If S is an ℓ -solid-resolving set, then it is also an $\{\ell\}$ -resolving set of G .*
- (ii) *If S is an $\{\ell + 1\}$ -resolving set, then it is also an ℓ -solid-resolving set of G .*

Theorem 6 shows the connection between $\{\ell\}$ -resolving sets and ℓ -solid-resolving sets. By means of Theorems 5 and 6 we can search for an $\{\ell\}$ -resolving set of G by considering first $(\ell - 1)$ -solid-resolving sets of G with the characterisation (1).

In Theorem 7, we give a general lower bound for the ℓ -solid-metric dimension of a graph, and in Theorem 8 we characterise the graphs for which this bound is obtained. A similar bound and characterisation for the $\{\ell\}$ -metric dimension of a graph have been proved in [2].

Theorem 7 *Let G be a graph with n vertices. When $1 \leq \ell \leq n - 1$, we have $\beta_\ell^s(G) \geq \ell + 1$.*

Theorem 8 *Let G be a connected graph with n vertices and let $2 \leq \ell \leq n - 1$. Then $\beta_\ell^s(G) = \ell + 1$ if and only if $n = \ell + 1$ or $G = S_{\ell+2}$.*

In [2], it was shown that when $\ell \geq 2$ certain types of vertices are included in every $\{\ell\}$ -resolving set. These vertices are called *forced vertices*. However, $\{1\}$ -resolving sets do not have any forced vertices, since $V \setminus \{v\}$ is a $\{1\}$ -resolving set of G for any $v \in V$. The following two theorems provide characterisations for forced vertices of ℓ -solid- and $\{\ell\}$ -resolving sets. As it turns out, the forced vertices of an $\{\ell\}$ -resolving set are exactly the same as those of an $(\ell - 1)$ -solid-resolving set. For $U \subseteq V$, let us denote

$$N[U] = \bigcup_{u \in U} N[u].$$

Theorem 9 *Let $\ell \geq 1$. A vertex $v \in V$ is a forced vertex of an ℓ -solid-resolving set if and only if there exists a set $U \subseteq V$ such that $v \notin U$, $|U| \leq \ell$ and $N(v) \subseteq N[U]$.*

Theorem 10 *Let $\ell \geq 2$. A vertex $v \in V$ is a forced vertex of an $\{\ell\}$ -resolving set if and only if there exists a set $U \subseteq V$ such that $v \notin U$, $|U| \leq \ell - 1$ and $N(v) \subseteq N[U]$.*

2 Flower snarks

The family of flower snarks is an infinite graph family for which the ℓ -solid-metric dimensions, when $\ell \leq 2$, and the $\{\ell\}$ -metric dimensions, when $\ell \leq 3$, are all nontrivial and different. Moreover, as it turns out, the $\{1\}$ -, 1-solid- and $\{2\}$ -metric dimensions are all constants, and the rest are dependent on the order of the graph.

In what follows, we define flower snarks by giving their construction (see Figure 1).

Construction. Let $n = 2k + 1$ be an odd integer, $n \geq 3$.

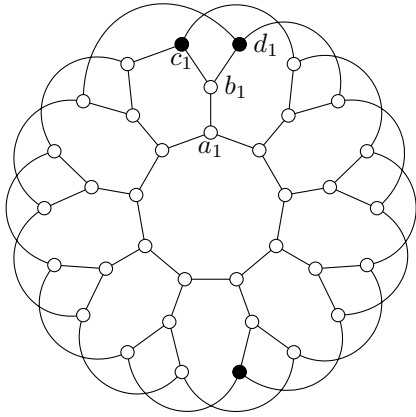

(a) A $\{1\}$ -resolving set.

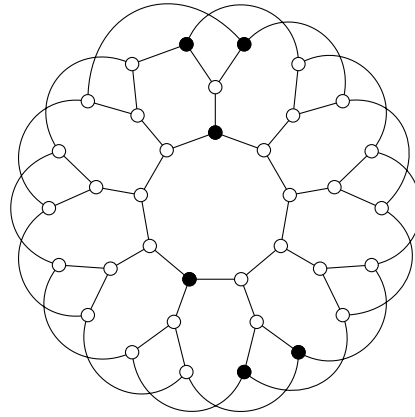

(b) A 1-solid-resolving set.

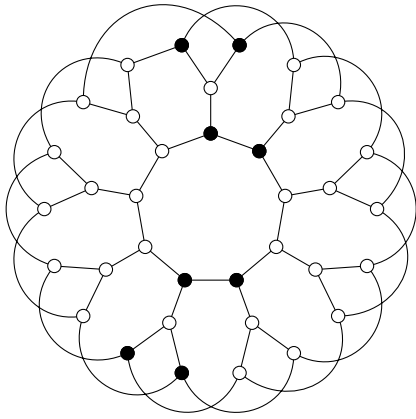

(c) A $\{2\}$ -resolving set.

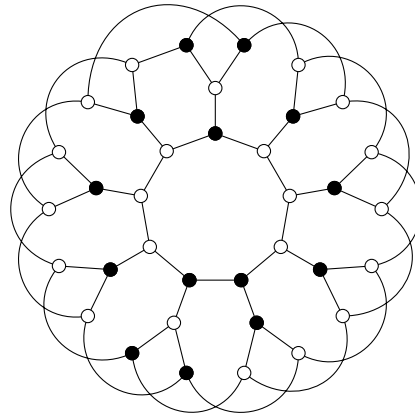

(d) A 2-solid-resolving set.

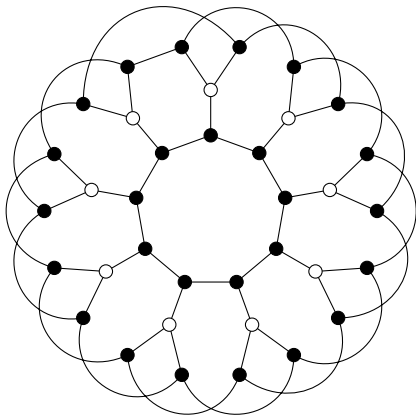

(e) A $\{3\}$ -resolving set.

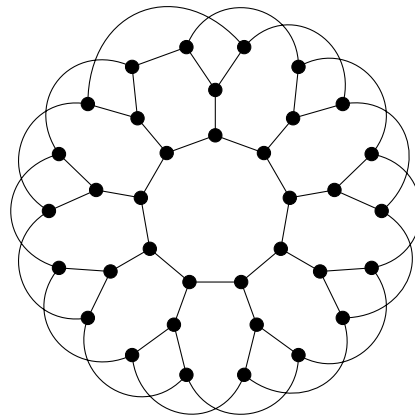

(f) A 3-solid-resolving set.

Figure 1: Optimal ℓ -solid- and $\{\ell\}$ -resolving sets of J_9 for $\ell \in \{1, 2, 3\}$.

1. First we draw n copies of the star S_4 . We denote by $T_i = \{a_i, b_i, c_i, d_i\}$ the vertices of the i th star, where the leaves of the star are a_i, c_i and d_i .
2. We connect the vertices a_i by drawing the cycle $a_1a_2 \dots a_na_1$.
3. We connect the remaining leaves of the stars by drawing the cycle $c_1c_2 \dots c_nd_1d_2 \dots d_nc_1$.

The resulting graph is the flower snark J_n with $4n$ vertices. The flower snark J_9 is illustrated in Figure 1.

In [4], it was shown that $\beta_1(J_n) = 3$ when $n \geq 5$. However, the proof for the upper bound $\beta_1(J_n) \leq 3$ is erroneous. The authors claim that the set $W = \{c_1, d_1, d_k\}$ is a resolving set of J_n , since all vertices have unique distance arrays with respect to W . However, we have $\mathcal{D}_W(a_1) = (2, 2, k + 1) = \mathcal{D}_W(b_n)$ and $\mathcal{D}_W(a_k) = (k + 1, k + 1, 2) = \mathcal{D}_W(b_{k+1})$. Thus, the set W is not a resolving set of J_n . Despite this, the upper bound holds. We can replace d_k with d_{k+1} in W , after which it is straightforward to correct the proof and verify that the new set is indeed a resolving set of J_n .

When $n \geq 5$, flower snarks do not have forced vertices for ℓ -solid-resolving sets if $\ell \leq 2$ and $\{\ell\}$ -resolving sets if $\ell \leq 3$. When $\ell \geq 3$, all vertices are forced vertices for ℓ -solid- and $\{\ell + 1\}$ -resolving sets. The following theorem discusses the values of ℓ -solid- and $\{\ell\}$ -metric dimensions of flower snarks with $n \geq 7$. When $n = 3$ or $n = 5$, the values of the metric dimensions differ slightly. However, since these two graphs are quite small, the values of their metric dimensions can be calculated swiftly with a computer.

Theorem 11 *Let $n \geq 7$ be an odd integer. We have*

$$\begin{array}{lll} \beta_1(J_n) = 3, & \beta_1^s(J_n) = 6, & \beta_2(J_n) \leq 8, \\ \beta_2^s(J_n) = n + 5, & \beta_3(J_n) = 3n, & \beta_3^s(J_n) = 4n. \end{array}$$

Optimal ℓ -solid- and $\{\ell\}$ -resolving sets of J_9 are illustrated in Figure 1.

References

- [1] A. Hakanen, V. Junnila, and T. Laihonen. The solid-metric dimension. **Theoret. Comput. Sci.**, 2019. In press.
- [2] A. Hakanen and T. Laihonen. On $\{\ell\}$ -metric dimensions in graphs. **Fundam. Inform.**, 162(2-3):143–160, 2018.
- [3] F. Harary and R. Melter. On the metric dimension of a graph. **Ars Comb.**, 2:191–195, 1976.
- [4] M. Imran, S. Bokhary, A. Ahmad, and A. Semaničová-Feňovčíková. On classes of regular graphs with constant metric dimension. **Acta Math. Sci.**, 33B(1):187–206, 2013.
- [5] S. Khuller, B. Raghavachari, and A. Rosenfeld. Landmarks in graphs. **Discrete Appl. Math.**, 70(3):217–229, 1996.
- [6] T. Laihonen. The metric dimension for resolving several objects. **Inform. Process. Lett.**, 116(11):694–700, 2016.
- [7] P. J. Slater. Leaves of trees. In **Proceedings of the Sixth Southeastern Conference on Combinatorics, Graph Theory, and Computing (Florida Atlantic Univ., Boca Raton, Fla., 1975)**, pages 549–559. Congressus Numerantium, No. XIV, Winipeg, Man., 1975. Utilitas Math.

Long A - B -paths have the edge-Erdős-Pósa property

Matthias Heinlein, Arthur Ulmer¹

¹ Institute of Optimization and Operations Research, Ulm University, Germany

EXTENDED ABSTRACT

Abstract

For a fixed integer ℓ a path is long if its length is at least ℓ . We prove that for all integers k and ℓ there is a number $f(k, \ell)$ such that for every graph G and vertex sets A, B the graph G either contains k edge-disjoint long A - B -paths or it contains an edge set F of size $|F| \leq f(k, \ell)$ that meets every long A - B -path. This is the edge analogue of a theorem of Montejano and Neumann-Lara (1984). We also prove a similar result for long A -paths and long \mathcal{S} -paths.

1 Introduction

Menger showed that in any graph with vertex sets A and B and for any $k \in \mathbb{N}$ there are either k disjoint A - B -paths in G or at most $k - 1$ vertices that intersect all A - B -paths (an A - B -path is a path from A to B that is internally disjoint from A and B). Montejano and Neumann-Lara [7] proved a similar result for *long* A - B -paths (paths of length at least ℓ for some fixed integer ℓ): for a fixed integer ℓ , any positive integer k and any graph G with vertex sets A and B there are either k disjoint long A - B -paths in G or a set of at most $(3\ell - 5)k$ vertices that intersects all long A - B -paths. Relating to the classic result of Erdős and Pósa [6] on the relation between the maximum number of disjoint cycles and the minimum size of a vertex set that intersects all cycles, we say that long A - B -paths have the *Erdős-Pósa property*.

More generally, a family of graphs \mathcal{H} (possibly with some extra structure, e.g. long A - B -paths) is said to have the *(vertex-)Erdős-Pósa property* if there is a function $f : \mathbb{N} \rightarrow \mathbb{R}$ such that for every $k \in \mathbb{N}$ and every graph G there are either k *vertex-disjoint* subgraphs of G that belong to \mathcal{H} or there is a set X of at most $f(k)$ *vertices* in G such that X intersects all subgraphs of G that belong to \mathcal{H} .

By replacing every occurrence of "vertex" by "edge" in the definition of the Erdős-Pósa property, an edge variant naturally arises. This property is weaker in the sense that we only need to find edge-disjoint subgraphs but at the same time it is stronger since we have to find a set of edges that intersects all these subgraphs. More precisely, a family of graphs \mathcal{H} (possibly with some extra structure) has the *edge-Erdős-Pósa property* if there is a function $f : \mathbb{N} \rightarrow \mathbb{R}$ such that for every $k \in \mathbb{N}$ and every graph G there are either k *edge-disjoint* subgraphs of G that belong to \mathcal{H} or there is a set X of at most $f(k)$ *edges* in G such that X intersects all subgraphs of G that belong to \mathcal{H} . We call a set of edges that intersects all subgraphs that belong to \mathcal{H} an *edge hitting set* for \mathcal{H} (or mostly just hitting set) and the function f a *hitting set function* for \mathcal{H} .

Long A - B -paths have the vertex-Erdős-Pósa property but do they have the edge-Erdős-Pósa property, too? We prove:

Theorem 1 *Long A - B -paths have the edge-Erdős-Pósa property.*

Bruhn, Heinlein and Joos [2] showed that long A -paths also have the vertex-Erdős-Pósa property (paths with both endvertices in a vertex set A and otherwise disjoint of A) and asked whether the same remains true for the edge variant. We answer this question:

Theorem 2 *Long A -paths have the edge-Erdős-Pósa property.*

From this results we can easily follow that also long \mathcal{S} -paths have the property (for a partition $\mathcal{S} = \{A_1, \dots, A_n\}$ of a set A this is an A -path with the endvertices in two different partition sets).

Theorem 3 *Long \mathcal{S} -paths have the edge-Erdős-Pósa property.*

The ordinary Erdős-Pósa property is fairly well studied. The most general result is arguably due to Robertson and Seymour on H -models [10], graphs that can be contracted to some graph H . The set of H -models has the Erdős-Pósa property if and only if H is planar, also see [12] for a recent proof of this with an essentially best possible hitting set function. In contrast, the edge-Erdős-Pósa property is less well understood. In particular, no edge-analogue of the result by Robertson and Seymour is possible. As in the vertex version, the set of H -models does not have the edge-Erdős-Pósa property for non-planar graphs [9]. But, contrary to the vertex version, the same is true for large (and subcubic) trees and also large ladders [4], which are both planar. Hence only one direction of that equivalence is still true in the edge version.

There are not many results on the edge-Erdős-Pósa property, besides some further small results on H -models [1, 3, 8, 11], it is only known that A - B -paths, A -paths and \mathcal{S} -paths have the edge-Erdős-Pósa property but any of these paths such that its length is congruent to some x modulo some m do not have it [2].

For a comprehensive list of Erdős-Pósa property results (vertex and edge version) see [2] or [9]. In this paper we will use the standard notation of Diestel [5].

We want to note here that Montejano and Neumann-Lara already claimed that long A - B -paths have the edge-Erdős-Pósa property, but they did not include a proof and only stated that it can be done in the same way as the vertex version, which we do not believe. At the end of their proof for the vertex version they obtain a graph in which all A - B -paths are long but this only works because they can put the first and last ℓ vertices of some paths into a potential hitting set. In the edge version we can only remove the first and last ℓ edges and then the construction might yield a graph in which we can use a shortcut from one of the first ℓ vertices to one of the last ℓ giving us a short A - B -path.

2 Proof of the Main Result

The idea of the proof is to do an induction on the length of the paths. The induction start $\ell = 1$ and also the case $\ell = 2$ follow almost immediately from the edge version of Menger's theorem. Now we fix some $\ell > 2$ and we assume that A - B -paths of length at least ℓ have the edge-Erdős-Pósa property. From this we can follow the following theorems (and in that order):

In a graph G with a vertex set A , an A -path is a path with both endvertices in A and otherwise disjoint from A (length at least 1, single vertices of A are not considered as A -paths).

Theorem 4 *A -paths of length at least $\ell - 1$ have the edge-Erdős-Pósa property.*

In A - B -paths we explicitly forbid vertices of A or B to be in the interior of the path. But for our proof we also need to look at paths which are allowed to do just that. For such paths we mark the set which can be used in the interior with a star. So an A^* - B -path is a path which starts in A , ends in B , and such that vertices of A can be in its interior but not of B . An A^* - B^* -path is a path which starts in A and ends in B and does not have any further restrictions.

Lemma 5 *If A and B are disjoint, then A^* - B -paths of length at least $\ell - 1$ have the edge-Erdős-Pósa property.*

With these two results we prove:

Lemma 6 *A^* - B^* -paths of length at least $\ell - 1$ have the edge-Erdős-Pósa property.*

Lastly, we can deduce from this (and thus finish the proof):

Theorem 7 *If A and B are disjoint, then A - B -paths of length at least $\ell + 1$ have the edge-Erdős-Pósa property.*

Also see Figure 1 for a more in-depth view of the dependencies.

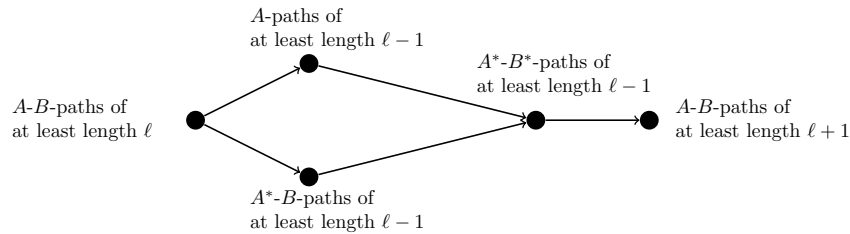

Figure 1: In this way we can deduce that if A - B -paths of length at least ℓ have the edge-Erdős-Pósa property, then also A - B -paths of length at least $\ell + 1$ have it.

3 Corollaries

Using the results of the previous section we can prove some further results. First of all we can prove our main result with non-disjoint sets A and B .

Theorem 8 *A - B -paths of length at least ℓ have the edge-Erdős-Pósa property.*

From the fact that A -paths of at least length ℓ have the edge-Erdős-Pósa property we can deduce some more results.

Corollary 9 *A^* -paths of length at least ℓ have the edge-Erdős-Pósa property.*

A more general type of A -paths are \mathcal{S} -paths. Let A be a set of vertices and $\mathcal{S} = \{A_1, \dots, A_n\}$ a partition of A , i.e. all A_i are pairwise disjoint and their union is A . An \mathcal{S} -path is a path that starts in some partition set A_i , ends in another set A_j and is otherwise disjoint of A .

Theorem 10 *\mathcal{S} -paths of length at least ℓ have the edge-Erdős-Pósa property.*

Finally we can also show that long cycles have the edge-Erdős-Pósa property. Note that this has already been proven by Bruhn, Heinlein and Joos [4], but we have a much shorter proof (although with a worse hitting set function).

Corollary 11 *Cycles of length at least ℓ have the edge-Erdős-Pósa property.*

References

- [1] H. Bruhn and M. Heinlein. K_4 -expansions have the edge-Erdős-Pósa property. In **Electronic Notes in Discrete Mathematics** 61: 163-167, 2017.
- [2] H. Bruhn, M. Heinlein, F. Joos. Frames, A -paths and the Erdős-Pósa property. In **SIAM J. Discrete Math.** 32(2): 1246-1260, 2018.

- [3] H. Bruhn, M. Heinlein, F. Joos. Long cycles have the edge-Erdős-Pósa property. In *Combinatorica* 39(1): 1-36, 2019.
- [4] H. Bruhn, M. Heinlein, F. Joos. The edge-Erdős-Pósa property. 2018.
- [5] R. Diestel. *Graph theory (5th edition)*. Springer-Verlag, 2017.
- [6] P. Erdős, L. Pósa. On independent circuits contained in a graph. In *Can. J. Math.* 7: 347–352, 1965.
- [7] L. Montejano, V. Neumann-Lara. A variation of Menger’s theorem for long paths. In *Journal of Combinatorial Series B* 36: 213-217, 1984.
- [8] J.-F. Raymond, I. Sau, D. M. Thilikos. An edge variant of the Erdős–Pósa property. *Discrete Math.* 339(8): 2027-2035, 2016.
- [9] J.-F. Raymond, D. Thilikos. Recent techniques and results on the Erdős–Pósa property. In *Disc. App. Math.* 231: 25-43, 2017.
- [10] N. Robertson, P. Seymour. Graph minors. V. Excluding a planar graph. In *J. Combin. Theory (Series B)* 41: 92-114, 1986.
- [11] A. Ulmer. Edge-Erdős-Pósa property. Master Thesis, 2017.
- [12] W.C. van Batenburg, T. Huynh, G. Joret, J.F. Raymond. A tight Erdős-Pósa function for planar minors. 2018.

Linear MIM-Width of Trees

Svein Høgemo, Jan Arne Telle, and Erlend Raa Vågset

Department of Informatics, University of Bergen, Norway

EXTENDED ABSTRACT

Abstract

We provide an $O(n \log n)$ algorithm computing the linear maximum induced matching width of an n -node tree and an optimal layout.

1 Background

The study of structural graph width parameters like tree-width, clique-width and rank-width has been ongoing for a long time, and their algorithmic use has been steadily increasing [1, 2]. The maximum induced matching width, denoted MIM-width, and the linear variant LMIM-width, are graph parameters having very strong modelling power introduced by Vatshelle in 2012 [3]. The LMIM-width parameter asks for a linear layout of vertices such that the bipartite graph induced by edges crossing any vertex cut has a maximum induced matching of bounded size. Belmonte and Vatshelle [4] showed that INTERVAL graphs, BI-INTERVAL graphs, CONVEX graphs and PERMUTATION graphs, where clique-width can be proportional to the square root of the number of vertices [5], all have LMIM-width 1 and an optimal layout can be found in polynomial time.

Since many well-known classes of graphs have bounded MIM-width or LMIM-width, algorithms that run in XP time in these parameters will yield polynomial-time algorithms on several interesting graph classes at once. Such algorithms have been developed for many problems: by Bui-Xuan et al [6] for the class of LCVS-VP - Locally Checkable Vertex Subset and Vertex Partitioning - problems, by Jaffke et al for non-local problems like FEEDBACK VERTEX SET [7, 8] and also for GENERALIZED DISTANCE DOMINATION [9], by Golovach et al [10] for output-polynomial ENUMERATION OF MINIMAL DOMINATING sets, by Bergougnoux and Kanté [11] for several Connectivity problems and by Galby et al for SEMITOTAL DOMINATION [12]. These results give a common explanation for many classical results in the field of algorithms on special graph classes and extends them to the field of parameterized complexity.

Note that very low MIM-width or LMIM-width still allows quite complex cuts compared to similarly defined graph parameters. For example, carving-width 1 allows just a single edge, maximum matching-width 1 a star graph, and rank-width 1 a complete bipartite graph. In contrast, LMIM-width 1 allows any cut where the neighborhoods of the vertices in a color class can be ordered linearly w.r.t. inclusion. In fact, it is an open problem whether the class of graphs having LMIM-width 1 can be recognized in polynomial-time or if this is NP-complete. Sæther et al [13] showed that computing the exact MIM-width and LMIM-width of general graphs is W-hard and not in APX unless NP=ZPP, while Yamazaki [14] shows that under the small set expansion hypothesis it is not in APX unless P=NP. The only graph classes where we know an exact polynomial-time algorithm computing LMIM-width are the above-mentioned classes INTERVAL, BI-INTERVAL, CONVEX and PERMUTATION that all have structured neighborhoods implying LMIM-width 1 [4]. Belmonte and Vatshelle also gave polynomial-time algorithms showing that CIRCULAR ARC and CIRCULAR PERMUTATION graphs have LMIM-width at most 2, while DILWORTH k and k -TRAPEZOID have LMIM-width at most k [4]. Recently, Fomin et al [15] showed that LMIM-width for the very general class of H -GRAPHS is bounded by $2|E(H)|$, and that a layout can be found in polynomial time if given an H -representation of the input graph. However, none of these results compute the exact LMIM-width. On the negative side, Mengel [16] has shown that STRONGLY CHORDAL SPLIT graphs, CO-COMPARABILITY graphs and CIRCLE graphs all can have MIM-width, and LMIM-width, linear in the number of vertices.

Just as LMIM-width can be seen as the linear variant of MIM-width, path-width can be seen as the linear variant of tree-width. Linear variants of other well-known parameters like clique-width and rank-width have also been studied. Arguably, the linear variant of MIM-width commands a more noteworthy position, since in contrast to these other linear parameters, for many well-known graph classes where the original parameter (MIM-width) is bounded then also the linear variant (LMIM-width) is bounded.

In this paper we give an $O(n \log n)$ algorithm computing the LMIM-width of an n -node tree. This is the first graph class of LMIM-width larger than 1 having a polynomial-time algorithm computing LMIM-width and thus constitutes an important step towards a better understanding of this parameter. The path-width of trees was first studied in the early 1990s by Möhring [17], with Ellis et al [18] giving an $O(n \log n)$ algorithm computing an optimal path-decomposition, and Skodinis [19] an $O(n)$ algorithm. In 2013 Adler and Kanté [20] gave linear-time algorithms computing the linear rank-width of trees and also the linear clique-width of trees, by reduction to the path-width algorithm. Even though LMIM-width is very different from path-width, the basic framework of our algorithm is similar to the path-width algorithm in [18].

2 Main result

For a bipartite graph G we denote by $\text{MIM}(G)$, or simply MIM if the graph is understood, the size of its Maximum Induced Matching, the largest number of edges whose endpoints induce a matching. Let σ be the linear order corresponding to the enumeration v_1, \dots, v_n of the nodes of G , this will also be called a linear layout of G . For any index $1 \leq i < n$ we have a cut of σ that defines the bipartite graph on edges "crossing the cut" i.e. edges with one endpoint in $\{v_1, \dots, v_i\}$ and the other endpoint in $\{v_{i+1}, \dots, v_n\}$. The maximum induced matching of G under layout σ is denoted $\text{mim}(\sigma, G)$, and is defined as the maximum, over all cuts of σ , of the value attained by the MIM of the cut, i.e. of the bipartite graph defined by the cut. The linear induced matching width – LMIM-width – of G is denoted $\text{lmw}(G)$, and is the minimum value of $\text{mim}(\sigma, G)$ over all possible linear orderings σ of the vertices of G .

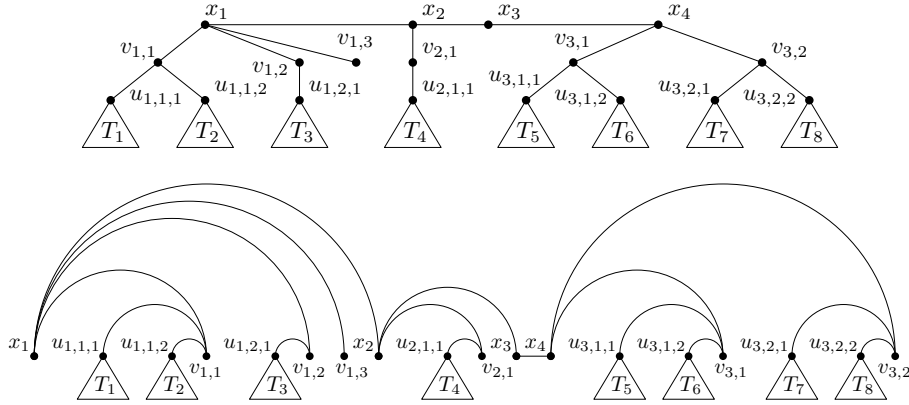

Figure 1: A tree with a path $P = (x_1, x_2, x_3, x_4)$, with nodes in $N[N[P]]$ featured, and below it the order given by the Path Layout Lemma

We start by proving the Path Layout Lemma, see Figure 1.

Lemma 1 (Path Layout Lemma) *Let T be a tree. If there exists a path $P = (x_1, \dots, x_p)$ in T such that every connected component of $T \setminus N[P]$ has LMIM-width $\leq k$ then $\text{lmw}(T) \leq k + 1$. Moreover, given the layouts for the components we can in linear time compute the layout for T .*

We then prove the Classification Theorem, see Figure 2.

Theorem 2 (Classification of LMIM-width of Trees) *For a tree T and $k \geq 1$ we have $lmw(T) \geq k + 1$ if and only if there is a node v such that after rooting T in v , at least three children of v themselves have at least one child whose rooted subtree has LMIM-width at least k*

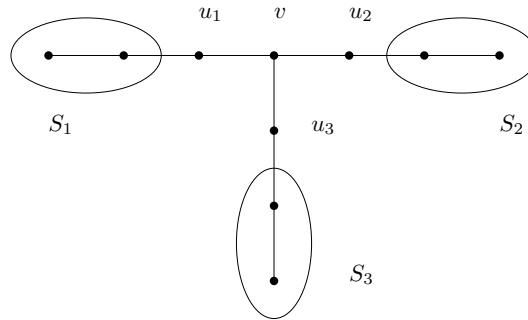

Figure 2: The smallest tree with LMIM-width 2.

From this it follows that the LMIM-width of an n -node tree is no more than $\log n$. Our $O(n \log n)$ algorithm computing LMIM-width of a tree T picks an arbitrary root r and proceeds bottom-up on the rooted tree T_r . We show how to assign labels to the rooted subtrees encountered in this process giving their LMIM-width. However, as with the algorithm computing pathwidth of a tree, the label is sometimes complex, consisting of LMIM-width of a sequence of subgraphs, of decreasing LMIM-width, that are not themselves full rooted subtrees. In particular, this happens if the subtree of T_r rooted in x has LMIM-width k and contains what we call a k -critical node y (being a node with two children having children whose rooted subtrees have LMIM-width k) that is a descendant of one of the children of x . We give an 8-way case analysis, depending among other things on the placement of k -critical nodes in the subtrees rooted at the children, providing a subroutine used to update the label at a node given the labels at all children. Our bottom-up algorithm will make calls to this subroutine in order to compute the complex labels and the LMIM-width. Finally, we use all the computed labels to lay out the tree in an optimal manner.

Theorem 3 *Given any tree T , $lmw(T)$ can be computed and an optimal layout can be found, in $O(n \log n)$ -time.*

References

- [1] P. Hliněný, S. Oum, D. Seese, and G. Gottlob, “Width parameters beyond tree-width and their applications,” *Comput. J.*, vol. 51, no. 3, pp. 326–362, 2008.
- [2] S. Oum, “Rank-width: Algorithmic and structural results,” *Discrete Applied Mathematics*, vol. 231, pp. 15–24, 2017.
- [3] M. Vatshelle, *New width parameters of graphs*. PhD thesis, University of Bergen, Norway, 2012.
- [4] R. Belmonte and M. Vatshelle, “Graph classes with structured neighborhoods and algorithmic applications,” *Theor. Comput. Sci.*, vol. 511, pp. 54 – 65, 2013.

- [5] M. C. Golumbic and U. Rotics, “On the clique-width of perfect graph classes,” in *Graph-Theoretic Concepts in Computer Science, 25th International Workshop, WG '99, Ascona, Switzerland, June 17-19, 1999, Proceedings*, pp. 135–147, 1999.
- [6] B.-M. Bui-Xuan, J. A. Telle, and M. Vatshelle, “Fast dynamic programming for locally checkable vertex subset and vertex partitioning problems,” *Theor. Comput. Sci.*, vol. 511, pp. 66 – 76, 2013.
- [7] L. Jaffke, O. Kwon, and J. A. Telle, “A unified polynomial-time algorithm for feedback vertex set on graphs of bounded mim-width,” in *35th Symposium on Theoretical Aspects of Computer Science, STACS 2018, February 28 to March 3, 2018, Caen, France*, pp. 42:1–42:14, 2018.
- [8] L. Jaffke, O. Kwon, and J. A. Telle, “Polynomial-time algorithms for the longest induced path and induced disjoint paths problems on graphs of bounded mim-width,” in *IPEC 2017, September 6-8, 2017, Vienna, Austria*, pp. 21:1–21:13, 2017.
- [9] Lars Jaffke, O-joung Kwon, Torstein J. F. Strømme, and Jan Arne Telle. Generalized distance domination problems and their complexity on graphs of bounded mim-width. In *IPEC 2018, August 20-24, 2018, Helsinki, Finland*, pages 6:1–6:14, 2018.
- [10] P. A. Golovach, P. Heggernes, M. M. Kanté, D. Kratsch, S. H. Sæther, and Y. Villanger, “Output-polynomial enumeration on graphs of bounded (local) linear mim-width,” *Algorithmica*, vol. 80, no. 2, pp. 714–741, 2018.
- [11] Benjamin Bergougnoux and Mamadou Moustapha Kanté. More applications of the neighborhood equivalence: connectivity and acyclicity constraints To appear European Symposium on Algorithms, Munich (Germany), ESA 2019
- [12] E. Galby, A. Munaro, and B. Ries, “Semitotal domination: New hardness results and a polynomial-time algorithm for graphs of bounded mim-width,” *CoRR*, vol. abs/1810.06872, 2018.
- [13] S. H. Sæther and M. Vatshelle, “Hardness of computing width parameters based on branch decompositions over the vertex set,” *Theor. Comput. Sci.*, vol. 615, pp. 120–125, 2016.
- [14] K. Yamazaki, “Inapproximability of rank, clique, boolean, and maximum induced matching-widths under small set expansion hypothesis,” *Algorithms*, vol. 11, no. 11, p. 173, 2018.
- [15] F. V. Fomin, P. A. Golovach, and J.-F. Raymond, “On the tractability of optimization problems on H-graphs,” in *Proc. ESA 2018*, pp. 30:1 – 30:14, 2018.
- [16] S. Mengel, “Lower bounds on the mim-width of some graph classes,” *Discrete Applied Mathematics*, vol. 248, pp. 28–32, 2018.
- [17] R. H. Möhring, “Graph problems related to gate matrix layout and pla folding,” in *Computational graph theory*, pp. 17–51, Springer, 1990.
- [18] J. A. Ellis, I. H. Sudborough, and J. S. Turner, “The vertex separation and search number of a graph,” *Inf. Comput.*, vol. 113, no. 1, pp. 50–79, 1994.
- [19] K. Skodinis, “Construction of linear tree-layouts which are optimal with respect to vertex separation in linear time,” *J. Algorithms*, vol. 47, no. 1, pp. 40–59, 2003.
- [20] I. Adler and M. M. Kanté, “Linear rank-width and linear clique-width of trees,” in *Graph-Theoretic Concepts in Computer Science - 39th International Workshop, WG 2013, Lübeck, Germany, June 19-21, 2013, Revised Papers*, pp. 12–25, 2013.

Ramsey properties of graphs of girth $3 \leq g \leq 8$

Jan Hubička¹, Matěj Konečný¹, and Jaroslav Nešetřil²

¹ Department of Applied Mathematics, Charles University, Prague

² Computer Science Institute of Charles University, Charles University, Prague

EXTENDED ABSTRACT

1 The edge-Ramsey property of graphs of girth $g \geq 4$

A class \mathcal{K} of finite graphs has the *edge-Ramsey property* (is *edge-Ramsey*) if for every graph $G \in \mathcal{K}$ there exists a graph $H \in \mathcal{K}$ such that for every 2-colouring of edges in H there exists a monochromatic induced subgraph of H isomorphic to G (a *copy* of G in H).

In the 1970s, independently by Erdős, Hajnal, Posa and by Deuber, Rödl (see [10] for references and a simple proof), it was established that the class of all finite graphs is edge-Ramsey. This result was subsequently strengthened to several special classes of graphs including the class of all triangle-free graphs [6, 8]. Nowadays, all these results can be seen as relatively easy special cases of the Nešetřil–Rödl theorem [9] which is a cornerstone² of the structural Ramsey theory.

It is however a long-standing open problem whether for every $g \geq 3$ the class \mathcal{G}_g of all finite graphs of girth at least g has the edge-Ramsey property (see e.g. [11, 7]). (Recall that the *girth* of a graph is the length of the shortest cycle contained in it.) We show:

Theorem 1 *The class \mathcal{G}_g has the edge-Ramsey property for every $3 \leq g \leq 8$.*

For $g = 3$ and $g = 4$ this follows from the aforementioned results on graphs and triangle-free graphs. A sketch of the proof of the edge-Ramsey property for graphs of girth at least five is shown in [11, Theorem 7.2] along with remark “Note that five in Theorem 7.2 can be with the same proof replaced by six. We have more complicated argument for seven; however the present method does not allow us to go further.” There has been no progress on the problem in the last three decades.

2 The \mathbf{A} -Ramsey property of graphs of girth $g \geq 4$

In addition to showing the edge-Ramsey property, we generalise the result for colouring special g -closed subgraphs. To state these results precisely, let us first introduce some key notions of the structural Ramsey theory, in particular the notion of an \mathbf{A} -Ramsey class.

In the following, we will consider graphs as a special case of (model-theoretic) structures. Let L be a language with relational symbols $R \in L$, each having its *arity*. An L -structure \mathbf{A} is a structure with *vertex set* A and relations $R_{\mathbf{A}} \subseteq A^r$ for every symbol $R \in L$ of arity r . If the set A is finite we call \mathbf{A} a *finite structure*. Given two L -structures \mathbf{A} and \mathbf{B} , a function $f: A \rightarrow B$ is an *embedding* $f: \mathbf{A} \rightarrow \mathbf{B}$ if it is injective and for every $R \in L$ of arity r it holds that $(v_1, v_2, \dots, v_r) \in R_{\mathbf{A}} \iff (f(v_1), f(v_2), \dots, f(v_r)) \in R_{\mathbf{B}}$.

For L -structures \mathbf{A} and \mathbf{B} , we denote by $\binom{\mathbf{B}}{\mathbf{A}}$ the set of all (induced) substructures of \mathbf{B} which are isomorphic to \mathbf{A} . Given a structure \mathbf{A} , a class of structures \mathcal{C} has the *\mathbf{A} -Ramsey property* (is *\mathbf{A} -Ramsey*) if for every $\mathbf{B} \in \mathcal{C}$ and for every positive integer k there exists a structure $\mathbf{C} \in \mathcal{C}$ such that the following holds: For every partition $\binom{\mathbf{C}}{\mathbf{A}}$ into k classes there exists $\tilde{\mathbf{B}} \in \binom{\mathbf{C}}{\mathbf{B}}$ such that $\binom{\tilde{\mathbf{B}}}{\mathbf{A}}$ belongs to one class of the partition. It is usual to shorten the last part of the definition to $\mathcal{C} \rightarrow (\mathbf{B})_k^{\mathbf{A}}$. Class \mathcal{C} is a *Ramsey class* if it is \mathbf{A} -Ramsey for every $\mathbf{A} \in \mathcal{C}$.

It is a well known fact that under mild assumptions, every Ramsey class consists of linearly ordered structures [13]. In the following, we will consider graphs endowed with a linear order on vertices. We see them as structures in a language consisting of a binary

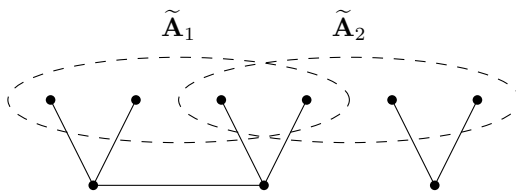

Figure 1: Ordered graphs of girth 5 are not Ramsey for colouring independent sets of size 4.

relation E representing the edges and a binary relation \leq representing the order. Denote by $\vec{\mathcal{G}}_g$ the class of all orderings of finite graphs of girth at least g . By the Nešetřil–Rödl theorem it follows:

Theorem 2 (Nešetřil–Rödl [9]) *The classes $\vec{\mathcal{G}}_3$ and $\vec{\mathcal{G}}_4$ are Ramsey classes.*

It is not difficult to see the following

Observation 3 *The classes $\vec{\mathcal{G}}_g$ are not Ramsey for $g > 4$.*

Proof. A counter-example for $g = 5$ is depicted in Figure 1. Here, \mathbf{A} is the independent set on four vertices and \mathbf{B} is the depicted structure containing two copies of \mathbf{A} which one can distinguish from each other by the (non-)existence of an edge connecting the midpoints of the respective paths of length 2. Because graphs of girth 5 contain no 4-cycles, in every \mathbf{C} and every $\tilde{\mathbf{B}} \in \binom{\mathbf{C}}{\mathbf{B}}$ the situation will be the same and therefore this gives a colouring of $\binom{\mathbf{C}}{\mathbf{A}}$ with no monochromatic copy of \mathbf{B} . \square

This example can be generalised to show that one can only hope to colour certain subgraphs:

Definition 4 *Let G be a graph. We say that its induced subgraph H is g -closed in G if for every two vertices $u \neq v \in G$ it holds that either uv is an edge of G or there is no path of length at most $\lfloor \frac{g-1}{2} \rfloor$ connecting u and v whose internal vertices all lie in $G \setminus H$.*

For ordered graphs \mathbf{A} and \mathbf{B} , we denote by $\binom{\mathbf{B}}{\mathbf{A}}_g$ the set of all (induced) g -closed substructures of \mathbf{B} which are isomorphic to \mathbf{A} . Given a structure \mathbf{A} , a class of structures \mathcal{C} is **\mathbf{A} -Ramsey for g -closed copies** if for every $\mathbf{B} \in \mathcal{C}$ and for every positive integer k there exists a structure $\mathbf{C} \in \mathcal{C}$ such that the following holds: For every partition $\binom{\mathbf{C}}{\mathbf{A}}_g$ into k classes there exists $\tilde{\mathbf{B}} \in \binom{\mathbf{C}}{\mathbf{B}}_g$ such that $\binom{\tilde{\mathbf{B}}}{\mathbf{A}}_g$ belongs to one class of the partition. We will shorten the last part of the definition to $\mathbf{C} \xrightarrow{g} \binom{\mathbf{B}}{\mathbf{A}}_k$. Class \mathcal{C} is a **Ramsey class for colouring g -closed copies** if it is **\mathbf{A} -Ramsey for colouring g -closed copies** for every $\mathbf{A} \in \mathcal{C}$.

A *star* is graph with a *central vertex* c , *leaf vertices* connected by an edge to c and no other edges or vertices (in other words, it is the complete bipartite graph where one bipartition consists of a single central vertex c). In particular, a vertex and an edge are stars. We prove:

Theorem 5 *Let $3 \leq g \leq 8$ and let \mathbf{A} be a disjoint union of stars endowed with an arbitrary linear ordering of vertices. Then for every $\mathbf{B} \in \vec{\mathcal{G}}_g$ there exists $\mathbf{C} \in \vec{\mathcal{G}}_g$ such that $\mathbf{C} \xrightarrow{g} \binom{\mathbf{B}}{\mathbf{A}}_2$. In other words, the class $\vec{\mathcal{G}}_g$ is **\mathbf{A} -Ramsey for g -closed copies**.*

3 Outline of the proofs

The main direction of attack is inspired by [11] where a connection between the hyperedge-Ramsey property of partial Steiner systems and the edge-Ramsey property of bipartite graphs of girth at least 5 is established. This is based on the following easy observation.

Observation 6 *Let G be a bipartite graph of girth at least 5 with parts P_1 and P_2 such that all vertices from P_1 have degree d . Consider the hypergraph $\mathcal{M} = (P_2, \{N_G(v) : v \in P_1\})$ on the vertex set P_2 where hyperedges are neighbourhoods of vertices from P_1 . Then \mathcal{M} is a partial $(d, 1)$ -Steiner system, that is, all hyperedges of \mathcal{M} have size d and for every two distinct hyperedges $M_1 \neq M_2$ it holds that $|M_1 \cap M_2| \leq 1$.*

Moreover, if G has girth at least 7 then \mathcal{M} contains no triangles (that is, distinct sets $M_1 \neq M_2 \neq M_3 \in \mathcal{M}$ with pairwise non-empty intersections).

This makes it possible to apply the following Ramsey results:

Theorem 7 (Nešetřil, Rödl [11]) *The class of all $(d, 1)$ -Steiner systems is hyperedge-Ramsey for every $d \geq 2$.*

And the following, which is a direct consequence of the main result of [2] (see also [4]):

Theorem 8 (Evans, Hubička, Nešetřil [2]) *The class of all triangle-free $(d, 1)$ -Steiner systems is hyperedge-Ramsey for every $d \geq 2$.*

With these ingredients one can show the following lemma using the proof outlined in [11].

Lemma 9 *The class all finite bipartite graph of girth g is edge-Ramsey for $g \in \{6, 8\}$.*

Proof (sketch). Given a bipartite graph G of girth g , we first construct a bipartite graph G' of girth g with parts P'_1 and P'_2 and a linear order on P'_2 , such that all vertices in P'_1 have degree d and moreover every colouring of edges of G' with 2 colours such that for every pair of vertices $v_1, v_2 \in P'_1$ it holds that for every $1 \leq i \leq d$ the i -th edge containing v_1 has the same colour as i -th edge containing v_2 (the order is determined by the order of P'_2) contains a monochromatic copy of G . This is possible by an application of the pigeonhole principle.

Next we use Observation 6 to turn G' into a $(d, 1)$ -Steiner system \mathcal{M} . Applying Theorem 7 (for $g = 6$) or Theorem 8 (for $g = 8$), we construct a $(d, 1)$ -Steiner system \mathcal{M}' such that every 2^d -colouring of hyperedges of \mathcal{M}' contains a monochromatic copy of \mathcal{M} . Finally, we construct a bipartite graph H of girth g based on \mathcal{M}' . Every 2-colouring of edges of H gives a 2^d -colouring of the hyperedges of \mathcal{M}' . A monochromatic copy of \mathcal{M} then gives a copy of G' satisfying the property above which in turn yields a monochromatic copy of G . \square

To show Theorem 1 it is then possible to adapt the Partite construction [12] with Lemma 9 playing the role of the partite lemma.

The proof of Theorem 2 requires a more refined approach inspired by the use of orientations and model-theoretic structures with functions in [3] where Ramsey results are given for the class of ordered directed graphs with out-degrees at most 2.

4 Concluding remarks and open problems

The notion of g -closed subgraphs seems to be the correct notion of subobjects in the context of classes $\vec{\mathcal{G}}_g$. We believe that our results are not tight, however, the proof technique does not seem to generalise. We strengthen the question about existence of edge-Ramsey graphs of girth $g \geq 9$ to:

Question 10 *Is the class $\vec{\mathcal{G}}_g$ Ramsey for colouring g -closed copies for every choice of $g \geq 3$?*

The connection to Steiner systems shows a somewhat surprising limitation of the current techniques for showing that a given class is Ramsey. In particular, it provokes the following two questions.

Question 11 *Is the class of all finite partial $(d, 1)$ -Steiner systems omitting odd cycles of length at most ℓ hyperedge-Ramsey for every $\ell > 3$ and $d \geq 2$?*

Question 12 *Does the class of all finite ordered partial $(d, 1)$ -Steiner systems omitting odd cycles of length at most ℓ have a precompact Ramsey expansion (in the sense of [13]) for colouring strong subsystems (see [1]) for every $\ell > 3$ and $d \geq 2$?*

There are two partial affirmative answers to Question 12, one for graphs (that is, $(2, 1)$ -Steiner systems) in [5], the other for $\ell = 1$ ([1]) and for $\ell = 3$ (an easy consequence of the main result of [2]). The general techniques in [5] can not be applied directly because an odd cycle in a Steiner system may have a homomorphism to a hyperedge.

An affirmative answer to Question 11 would immediately lead to a strengthening of Theorem 1 to graphs of arbitrary girth. The results from the previous paragraph imply that the answer to Question 11 is positive for $\ell = 1$ and $\ell = 3$.

References

- [1] Vindya Bhat, Jaroslav Nešetřil, Christian Reiher, and Vojtěch Rödl. A ramsey class for steiner systems. *Journal of Combinatorial Theory, Series A*, 154:323 – 349, 2018.
- [2] David M. Evans, Jan Hubička, and Jaroslav Nešetřil. Ramsey properties and extending partial automorphisms for classes of finite structures. To appear in *Fundamenta Mathematicae*, arXiv:1705.02379, 2017.
- [3] David M. Evans, Jan Hubička, and Jaroslav Nešetřil. Automorphism groups and Ramsey properties of sparse graphs. *Proceedings of the London Mathematical Society*, 119(2):515–546, 2019.
- [4] Jan Hubička and Jaroslav Nešetřil. Ramsey classes with closure operations (selected combinatorial applications). In Steve Butler, Joshua Cooper, and Glenn Hurlbert, editors, *Connections in Discrete Mathematics: A Celebration of the Work of Ron Graham*, page 240–258. Cambridge University Press, 2018.
- [5] Jan Hubička and Jaroslav Nešetřil. All those Ramsey classes (Ramsey classes with closures and forbidden homomorphisms). *Advances in Mathematics*, 356C:106791, 2019.
- [6] J Nešetřil and V Rödl. A Ramsey graph without triangles exists for any graph without triangles. *Infinite and finite sets III*, 10:1127–1132, 1975.
- [7] Jaroslav Nešetřil. Ramsey theory. In Ronald L. Graham, Martin Grötschel, and László Lovász, editors, *Handbook of Combinatorics*, volume 2, pages 1331–1403. MIT Press, Cambridge, MA, USA, 1995.
- [8] Jaroslav Nešetřil and Vojtěch Rödl. The Ramsey property for graphs with forbidden complete subgraphs. *Journal of Combinatorial Theory, Series B*, 20(3):243–249, 1976.
- [9] Jaroslav Nešetřil and Vojtěch Rödl. A structural generalization of the Ramsey theorem. *Bulletin of the American Mathematical Society*, 83(1):127–128, 1977.
- [10] Jaroslav Nešetřil and Vojtěch Rödl. A simple proof of the galvin-ramsey property of the class of all finite graphs and a dimension of a graph. *Discrete Mathematics*, 23(1):49–55, 1978.
- [11] Jaroslav Nešetřil and Vojtěch Rödl. Strong Ramsey theorems for Steiner systems. *Transactions of the American Mathematical Society*, 303(1):183–192, 1987.
- [12] Jaroslav Nešetřil and Vojtěch Rödl. The partite construction and Ramsey set systems. *Discrete Mathematics*, 75(1):327–334, 1989.
- [13] Lionel Nguyen Van Thé. A survey on structural Ramsey theory and topological dynamics with the Kechris-Pestov-Todorčević correspondence in mind. *Selected Topics in Combinatorial Analysis*, 17(25):189–207, 2015.

Extending partial automorphisms

Jan Hubička¹, Matěj Konečný¹, and Jaroslav Nešetřil²

¹ Department of Applied Mathematics, Charles University, Prague

² Computer Science Institute of Charles University, Charles University, Prague

EXTENDED ABSTRACT

Let G be a graph. A partial function $f: V(G) \rightarrow V(G)$ with finite domain is a *partial automorphism of G* if it is an isomorphism of the subgraphs induced by G on the domain and range of f . We say that a graph H is an *EPPA-witness* for G if it contains G as an induced subgraph and every partial automorphism of G can be extended to an automorphism of H . Note that these notions naturally extends to hypergraphs, or even more generally, model-theoretic structures with relations and functions.

We say that a class \mathcal{C} of finite structures (e.g. graphs) has the *extension property for partial automorphisms (EPPA)* if for every $\mathbf{A} \in \mathcal{C}$ there is $\mathbf{B} \in \mathcal{C}$ which is an EPPA-witness for \mathbf{A} .

EPPA has been studied for almost three decades, but despite being a purely combinatorial property, it has been mostly considered in the context of model theory and infinite permutation groups (where it originally comes from and where it has many applications). We believe that it deserves more combinatorial attention and in aid of it, we first briefly present the status quo and then state several open problems which should have combinatorial solutions.

1 Introduction

EPPA is sometimes also called the *Hrushovski property*, because in 1992 Hrushovski [6] proved EPPA for the class of all finite graphs. Hrushovski's motivation came from the study of infinite topological groups (his result was used by Hodges, Hodkinson, Lascar and Shelah to prove the small index property for the countable random graph [4]) and his proof was also group theoretical. However, in 2000, Herwig and Lascar [3] gave a simple combinatorial proof by embedding graphs into the complement of the Kneser graph:

Proof. [Sketch of proof of Hrushovski's theorem by Herwig and Lascar] Let G be a finite graph. First, for simplicity, assume that G is k -regular for some k . Define H to be the complement of the Kneser graph on vertex set $\binom{E(G)}{k}$, that is, the vertices of H are all k -subsets of $E(G)$ and $XY \in E(H)$ if and only if $X \cap Y \neq \emptyset$. Note that every permutation of $E(G)$ induces an automorphism of H .

Next we define an embedding ψ of G into H putting $\psi(v) = \{e \in E(G) : v \in e\}$, that is, we send every vertex of G to the set of edges incident with it. It is straightforward to check that the graph induced by H on $\psi(V(G))$ is isomorphic to G .

Finally we show that H extends all partial automorphisms of the graph induced by it on $\psi(V(G))$. Take one such partial automorphism φ . We can treat it like an automorphism of G which thereby gives a partial permutation of $E(G)$. It suffices to extend this permutation to a permutation $\pi: E(G) \rightarrow E(G)$ in such a way that for every $v \in V(G)$ there is $v' \in V(G)$ such that $\pi(\psi(v)) = \psi(v')$, where $\pi(\psi(v)) = \{\pi(e) : e \in \psi(v)\}$. This is possible because of the k -regularity assumption. Now it is straightforward to verify that the automorphism of H induced by π extends φ and hence we are done.

If G is not k -regular, one can add “half-edges” to every vertex to get a regular “graph”. \square

Let us remark that using a similar construction one can prove EPPA for classes of hypergraphs, or even more generally, relational structures in a finite language.

Since Hrushovski's result, EPPA has been shown for many more classes of structures, such as the class of all finite metric spaces [13] (see also [7] for a short combinatorial proof), classes of structures omitting finitely many homomorphisms [3, 8] or the class of all finite

two-graphs [1]. EPPA for metric spaces is essentially equivalent to a variant of EPPA for graphs with distance-preserving maps, while EPPA for two-graphs is equivalent to a variant of EPPA for graphs with the so-called *switching isomorphisms*.

Most of the results on EPPA use—directly or indirectly—some deep results from group theory on the profinite topology on free groups. Only recently, the authors together with other co-authors developed the ideas of Hodkinson and Otto [5] into the *method of valuation functions*, a purely combinatorial method for proving EPPA (see Section 3).

2 Connections to model theory

We say that a structure is *homogeneous* if it is an EPPA-witness for itself. The study of homogeneous structures was initiated by Fraïssé in the 1950s and has been an active area ever since. In particular, there are several major classification results. For example, we know that the finite homogeneous graphs are the disjoint unions of cliques of the same size and their complements, the 5-cycle and the line graph of $K_{3,3}$. We also know that the countably infinite homogeneous graphs are the disjoint unions of cliques of the same size (possibly infinite) and their complements, the countable random graph, its K_n -free variants and their complements [12]. In other words, homogeneity is a very strong property and there are only a few graph examples.

The following easy observation links EPPA with homogeneous structures.

Observation 1 *Let \mathcal{C} be a class of finite structures which has EPPA. We inductively define a sequence $\mathbf{B}_0 \subseteq \mathbf{B}_1 \subseteq \dots$ of structures from \mathcal{C} such that \mathbf{B}_0 is an arbitrary structure from \mathcal{C} and \mathbf{B}_i is an EPPA-witness for \mathbf{B}_{i-1} (it exists by the assumption that \mathcal{C} has EPPA). It is easy to see that $\mathbf{F} = \bigcup_{i=0}^{\infty} \mathbf{B}_i$ is a homogeneous structure.*

If \mathcal{C} is hereditary (that is, closed under taking substructures), has only countably many members up to isomorphism and has the *joint embedding property* (that is, for every \mathbf{A}_1 and \mathbf{A}_2 from \mathcal{C} there is $\mathbf{B} \in \mathcal{C}$ which contains both \mathbf{A}_1 and \mathbf{A}_2 as substructures), one can alter the construction a bit and guarantee that \mathcal{C} will be precisely the class of all finite substructures of \mathbf{F} . Since all these three conditions are very natural, this means that candidate classes for EPPA are restricted by the classification programme of homogeneous structures.

Remark 2 *Let us remark that this construction also proves that EPPA for the class of all finite substructures of a countable homogeneous structure is equivalent to the fact that the automorphism group of the homogeneous structure can be written as the closure of a chain of finite compact subgroups (in the so-called pointwise-convergence topology).*

3 The method of valuation functions

In this section, we give another proof of Hrushovski’s theorem using the method of valuation functions, which was first used by Hodkinson and Otto [5] and recently developed by the authors and their co-authors [2, 1, 7, 8, 11, 10].

Proof. We first define graphs H_n for every $n \geq 1$. The vertices of H_n are all pairs (i, f) , where $i \in [n]$ and f is a function $[n] \rightarrow \{0, 1\}$. We call i the *projection* and f the *valuation* of the given vertex and denote $\pi(i, f) = i$ and $\chi(i, f) = f$. Vertices $u, v \in V(H_n)$ form an edge of H_n if and only if $\chi(u)(\pi(v)) \neq \chi(v)(\pi(u))$.

Note that every permutation of $[n]$ induces an automorphism of H_n (by permuting the projections and valuations accordingly). Also note that for every $i, j \in [n]$ the following function (called a *flip*) is also an automorphism of H_n : $F_{i,j}(k, f) = (k, f')$, where

$$f'(\ell) = \begin{cases} 1 - f(\ell) & \text{if } \{i, j\} = \{k, \ell\}, \\ f(\ell) & \text{otherwise.} \end{cases}$$

These graphs H_n will serve as our EPPA-witnesses. Let G be a finite graph and assume, without loss of generality, that $V(G) = [n]$ for some integer n . Let $M(G)$ be the asymmetric adjacency matrix of G , that is, $M(G)_{ij} = 1$ if $i < j$ and $ij \in E(G)$ and $M(G)_{ij} = 0$ otherwise. Define function $\psi: G \rightarrow H_n$ as $\psi(v) = (v, M(G)_{v*})$, where by $M(G)_{v*}$ we mean the v -th row of $M(G)$ understood as a function $[n] \rightarrow \{0, 1\}$, and note that ψ is an embedding of G into H_n .

Now it remains to show that H_n extends partial automorphisms of $\psi(G)$. Let φ be such a partial automorphism. It induces a partial permutation of $[n]$, which we extend arbitrarily to a permutation $\hat{\varphi}$ of $[n]$. Next we define a set $\mathcal{F} \subseteq [n]^2$ by putting $(i, j) \in \mathcal{F}$ if and only if $i < j$ and for at least one of i, j —without loss of generality let it be i —it holds that $(i, M(G)_{i*})$ is in the domain of φ and moreover

$$\chi(\psi(i, M(G)_{i*}))(\hat{\varphi}(j)) \neq \chi(i, M(G)_{i*})(j),$$

that is, if φ and $\hat{\varphi}$ change the mutual valuations of the pair. Note that if both $(i, M(G)_{i*})$ and $(j, M(G)_{j*})$ are in the domain of φ , the outcome is the same for both of them, because φ is a partial automorphism of $\psi(G)$.

Finally observe that the composition of all $F_{i,j}$'s for every $(i, j) \in \mathcal{F}$ and the automorphism of H_n induced by $\hat{\varphi}$ is an automorphism of H_n which extends φ . \square

This idea can again be generalised for arbitrary relational structures (where the valuation functions can have higher arities). However, it generalises even further. Note that in the construction of H_n , we have combined an existing EPPA object (the projection, in this case it is just the set $[n]$ with no structure which is an EPPA-witness for itself) with a suitable notion of valuations and flips to get more complicated EPPA-witnesses. In this way, one can, in a purely combinatorial way using no deep group theory, prove EPPA for classes of K_n -free graphs [5], for classes with unary functions [2], for two-graphs [1], for classes of structures with relations and unary functions omitting finitely many homomorphisms [8] and for other classes of structures.

Remark 3 *Another reason why the method of valuation functions is appealing to us is that it behaves similarly as proof techniques in the structural Ramsey theory. [9]*

4 Open problems

We would like to conclude with several open problems of combinatorial flavour.

Problem 4 *Determine the correct growth-rates for the number of vertices of EPPA-witnesses.*

For example, the valuation-function method gives EPPA-witnesses on $n2^n$ vertices for graphs on n vertices, while the Herwig–Lascar proof gives $\mathcal{O}((kn)^k)$ for k -regular graphs. There are no non-trivial lower bounds known to the authors.

The results of Section 2 can be refined. If a class \mathcal{C} has the joint embedding property and **D**-EPPA for a structure **D** (that is, a variant of EPPA extending those partial automorphisms whose domain is isomorphic to **D**), then \mathcal{C} has the **D**-*amalgamation property*, that is, for every two structures **B**₁, **B**₂ $\in \mathcal{C}$, both containing **D** as a substructure, there is **E** $\in \mathcal{C}$ containing both **B**₁ and **B**₂ as substructures such that they overlap by **D**. This gives further restrictions on which classes can have which variants of EPPA.

Problem 5 *Find some non-trivial examples of classes which have a weaker variant of EPPA (e.g., one only wants to extend partial automorphisms which satisfy certain properties).*

As a particular instance of this problem, we ask the following questions:

Question 6 *Let \mathcal{C} be the class of all combinatorial embeddings of all planar graphs (that is, we know the circular orientation of all edges around each vertex, and hence we know in*

particular the faces). Is it true that for every $\mathbf{A} \in \mathcal{C}$ there is $\mathbf{B} \in \mathcal{C}$ containing \mathbf{A} as a sub-embedding such that every partial automorphism $f: \mathbf{A} \rightarrow \mathbf{A}$ whose domain is a face of \mathbf{A} extends to an automorphism of \mathbf{B} ?

Question 7 What is the answer to a variant of Question 6, where we consider the class of all combinatorial embedding of all planar triangulations?

The following two questions are important open problems in the area, maybe waiting for an ingenious combinatorial insight:

Question 8 Does the class of all finite tournaments have EPPA?

Question 9 Does the class of all finite partial Steiner systems have EPPA? (Here, a partial Steiner system is a 3-uniform hypergraph such that every two vertices are together in at most one hyperedge.)

References

- [1] David M. Evans, Jan Hubička, Matěj Konečný, and Jaroslav Nešetřil. EPPA for two-graphs and antipodal metric spaces. Submitted, arXiv:1812.11157, 2018.
- [2] David M. Evans, Jan Hubička, and Jaroslav Nešetřil. Ramsey properties and extending partial automorphisms for classes of finite structures. To appear in *Fundamenta Mathematicae*, arXiv:1705.02379, 2017.
- [3] Bernhard Herwig and Daniel Lascar. Extending partial automorphisms and the profinite topology on free groups. *Transactions of the American Mathematical Society*, 352(5):1985–2021, 2000.
- [4] Wilfrid Hodges, Ian Hodkinson, Daniel Lascar, and Saharon Shelah. The small index property for ω -stable ω -categorical structures and for the random graph. *Journal of the London Mathematical Society*, 2(2):204–218, 1993.
- [5] Ian Hodkinson and Martin Otto. Finite conformal hypergraph covers and Gaifman cliques in finite structures. *Bulletin of Symbolic Logic*, 9(03):387–405, 2003.
- [6] Ehud Hrushovski. Extending partial isomorphisms of graphs. *Combinatorica*, 12(4):411–416, 1992.
- [7] Jan Hubička, Matěj Konečný, and Jaroslav Nešetřil. A combinatorial proof of the extension property for partial isometries. *Commentationes Mathematicae Universitatis Carolinae*, 60(1):39–47, 2019.
- [8] Jan Hubička, Matěj Konečný, and Jaroslav Nešetřil. All those EPPA classes (strengthenings of the Herwig-Lascar theorem). arXiv:1902.03855, 2019.
- [9] Jan Hubička and Jaroslav Nešetřil. All those Ramsey classes (Ramsey classes with closures and forbidden homomorphisms). *Advances in Mathematics*, 356C:106791, 2019.
- [10] Jan Hubička, Colin Jahel, Matěj Konečný, and Marcin Sabok. Extension property for partial automorphisms of the n -partite and semi-generic tournaments. To appear, 2019.
- [11] Matěj Konečný. Extending partial isometries of antipodal graphs. *Discrete Mathematics*, page 111633, 2019. <https://doi.org/10.1016/j.disc.2019.111633>.
- [12] Alistair H. Lachlan and Robert E. Woodrow. Countable ultrahomogeneous undirected graphs. *Transactions of the American Mathematical Society*, pages 51–94, 1980.
- [13] Sławomir Solecki. Extending partial isometries. *Israel Journal of Mathematics*, 150(1):315–331, 2005.

The chromatic number and switching chromatic number of 2-edge-colored graphs of bounded degree

Fabien Jacques, Mickael Montassier, and Alexandre Pinlou

LIRMM, Université de Montpellier, CNRS, France

EXTENDED ABSTRACT

The notion of homomorphisms of 2-edge-colored graphs has already been studied as a way of extending classical results in graph coloring such as Hadwiger's conjecture. Guenin [5] introduced the notion of switching homomorphisms for its relation with a well-known conjecture of Seymour. In 2012, this notion has been further developed by Naserasr et al. [6] as it captures a number of well-known conjectures that can be reformulated using the definition of switching homomorphisms. In this extended abstract, we study homomorphisms of 2-edge colored graphs and switching homomorphisms of bounded degree graphs.

A *2-edge-colored graph* $G = (V, E, s)$ is a simple graph (V, E) with two kinds of edges: positive and negative edges. The signature $s : E(G) \rightarrow \{-1, +1\}$ assigns to each edge its sign. In the sequel, \mathcal{D}_k (resp. \mathcal{D}_k^c) denotes the class of 2-edge-colored graphs (resp. connected 2-edge-colored graphs) with maximum degree k .

Given two 2-edge-colored graphs G and H , the mapping $\varphi : V(G) \rightarrow V(H)$ is a *homomorphism* if φ maps every edge of G to an edge of H with the same sign. This can be seen as coloring the graph G by using the vertices of H as colors. The target graph H gives us the rules that this coloring must obey. If vertices 1 and 2 in H are connected with a positive (resp. negative) edge, then every pair of adjacent vertices in G colored with 1 and 2 must be connected with a positive (resp. negative) edge. The *chromatic number* $\chi_2(G)$ of a 2-edge-colored graph G is the order of a smallest 2-edge-colored graph H such that G admits a homomorphism to H . The chromatic number $\chi_2(\mathcal{C})$ of a class of 2-edge-colored graphs \mathcal{C} is the maximum of the chromatic numbers of the graphs in the class. This number can be infinite.

2-edge-colored graphs are, in some sense, similar to oriented graphs since a pair of vertices can be adjacent in two different ways in both kinds of graphs: with a positive or a negative edge in the case of 2-edge-colored graphs, with a toward or a backward arc in the oriented case.

The notion of homomorphism of oriented graphs has been introduced by Courcell [3] in 1994 and has been widely studied since then. Due to the similarity above-mentioned, we try to adapt techniques used to study the homomorphisms of oriented graphs of bounded degree to 2-edge-colored graphs of bounded degree. We also study switching homomorphisms of 2-edge-colored graphs in order to obtain results on signed graphs.

Switching a vertex v of a 2-edge-colored graph corresponds to reversing the signs of all edges incident to v .

Two 2-edge-colored graphs G and G' are *switching equivalent* if it is possible to turn G into G' after some number of switches. We call the classes created by this equivalence relation *switching classes* (note that switching classes are equivalent to the notion of signed graphs).

Given two 2-edge-colored graphs G and H , the mapping $\varphi : V(G) \rightarrow V(H)$ is a *switching homomorphism* if there is a graph G' switching equivalent to G such that φ maps every edge of G' to an edge of H with the same sign. The *switching chromatic number* $\chi_s(G)$ of a 2-edge-colored graph G is the order of a smallest 2-edge-colored graph H such that G admits a switching homomorphism to H .

Table 1 summarizes results on the chromatic number and switching chromatic number of the classes of (connected) 2-edge-colored graphs of bounded degree.

The first two lines of Table 1 are more or less folklore. Let us explain in the following the difference that exists between the connected case and the non-connected case for the

	$\chi_2(\mathcal{D}_k)$	$\chi_2(\mathcal{D}_k^c)$	$\chi_s(\mathcal{D}_k)$	$\chi_s(\mathcal{D}_k^c)$
$k = 1$	$\chi_2(\mathcal{D}_k) = 3$	$\chi_2(\mathcal{D}_k^c) = 2$	$\chi_s(\mathcal{D}_k) = \chi_s(\mathcal{D}_k^c) = 2$	
$k = 2$	$\chi_2(\mathcal{D}_k) = 6$	$\chi_2(\mathcal{D}_k^c) = 5$	$\chi_s(\mathcal{D}_k) = \chi_s(\mathcal{D}_k^c) = 4$	
$k = 3$	$8 \leq \chi_2(\mathcal{D}_k^c) \leq \chi_2(\mathcal{D}_k) \leq 11$		$6 \leq \chi_s(\mathcal{D}_k) \leq 7$ [1]	$\chi_s(\mathcal{D}_k^c) = 6$ [1]
$k = 4$	$12 \leq \chi_2(\mathcal{D}_k^c) \leq \chi_2(\mathcal{D}_k) \leq 31$		$10 \leq \chi_s(\mathcal{D}_k^c) \leq \chi_s(\mathcal{D}_k) \leq 16$	
$k \geq 5$	$2^{\frac{k}{2}} \leq \chi_2(\mathcal{D}_k^c) \leq \chi_2(\mathcal{D}_k) \leq 2^{k+1}(k-1)^2$ [4]		$\chi_s(\mathcal{D}_k^c) \leq \chi_s(\mathcal{D}_k) \leq 2^{k+1}(k-1)^2$ [4]	

Table 1: Results on the chromatic number and switching chromatic number of the classes of (connected) 2-edge-colored graphs of bounded degree.

chromatic number of 2-edge-colored graphs with maximum degree 1 or 2. An edge of a 2-edge-colored graph has chromatic number 2 and thus $\chi_2(\mathcal{D}_1^c) = 2$; however, a 2-edge-colored graph with two non-adjacent edges, one positive and one negative, has chromatic number 3 (the target graph needs a positive and a negative edge, hence at least three vertices) and thus $\chi_2(\mathcal{D}_1) = 3$. We therefore have a difference between the chromatic numbers of connected and non-connected 2-edge-colored graphs with maximum degree 1. This difference does not exist for switching homomorphisms since a negative edge can be changed into a positive one after a switch. This difference (and lack thereof for switching homomorphisms) appears also in graphs with maximum degree 2. We have $\chi_2(\mathcal{D}_2) \geq 6$ since there is no 2-edge-colored graph on 5 vertices that can color all the four graphs depicted in Figure 1. However, every connected 2-edge-colored graph with maximum degree 2 admits a homomorphism to one of the two graphs on 5 vertices depicted in Figure 2 and thus $\chi_2(\mathcal{D}_2^c) \leq 5$. In order to color any graph of \mathcal{D}_2 , we need a target graph that contains both graphs depicted in Figure 2 as subgraphs. This is possible with 6 vertices so $\chi_2(\mathcal{D}_2) = 6$. We do not know yet if this is also the case for graphs with maximum degree at least 3.

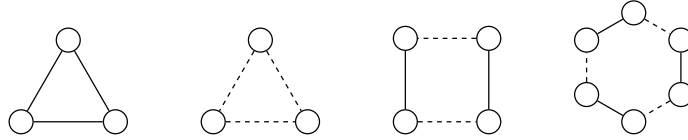

Figure 1: Four examples of 2-edge-colored graphs with chromatic number 5.

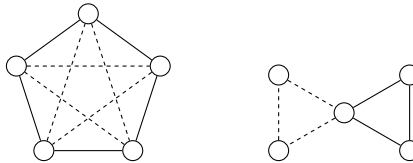

Figure 2: Target graphs for connected 2-edge-colored graphs of maximum degree 2.

The last three lines of Table 1 are dedicated to graphs with maximum degree at least 3. Our main results are the following:

Theorem 1 *We have:*

- $8 \leq \chi_2(\mathcal{D}_3) \leq 11$,
- $12 \leq \chi_2(\mathcal{D}_4) \leq 31$,
- $10 \leq \chi_s(\mathcal{D}_4) \leq 16$.

In order to find an upper bound for a class of graphs, we need to find a target graph that can color every graph in the class. In the case of oriented homomorphisms, oriented graphs that are antiautomorphic, K_n -transitive for some n , or that have Property $P_{n,k}$ for some n and k are good candidates. We analogously define these properties in terms of 2-edge-colored graphs.

A 2-edge-colored graph (V, E, s) is said to be *antiautomorphic* if it is isomorphic to $(V, E, -s)$.

A 2-edge-colored graph $G = (V, E, s)$ is said to be *K_n -transitive* if for every pair of cliques $\{u_1, u_2, \dots, u_n\}$ and $\{v_1, v_2, \dots, v_n\}$ in G such that for all $i \neq j$, $s(u_i u_j) = s(v_i v_j)$ there exists an automorphism that maps u_i to v_i for all i . For $n = 1, 2$, or 3 , we say that the graph is *vertex*, *edge*, or *triangle-transitive*, respectively.

A 2-edge-colored graph G has *Property $P_{k,n}$* if for every sequence of k distinct vertices (v_1, v_2, \dots, v_k) that induces a clique in G and for every sign vector $(\alpha_1, \alpha_2, \dots, \alpha_k) \in \{-1, +1\}^k$ there exist at least n distinct vertices $\{u_1, u_2, \dots, u_n\}$ such that $s(v_i u_j) = \alpha_i$ for $1 \leq i \leq k$ and $1 \leq j \leq n$.

Given an integer $q \equiv 1 \pmod{4}$, we consider the family of complete signed Paley graphs SP_q built from the field of order q which has the above-mentioned properties. The vertices of SP_q are the elements of the field of order q and $s(uv) = +1$ if $u - v$ is a square and $s(uv) = -1$ otherwise.

Lemma 2 ([7]) *Graph SP_q is vertex-transitive, edge-transitive, antiautomorphic, and has properties $P_{1, \frac{q-1}{2}}$ and $P_{2, \frac{q-5}{4}}$.*

Let us consider the following operation. Given a 2-edge-colored graph G , we create the *antitwinned graph* of G denoted by $\rho(G)$ as follows. Let G^{+1}, G^{-1} be two copies of G . The vertex corresponding to $v \in V(G)$ in G^i is denoted by v_i , $V(\rho(G)) = V(G^+) \cup V(G^-)$, $E(\rho(G)) = \{u_i v_j : uv \in E(G), i, j \in \{-1, +1\}\}$ and $s_{\rho(G)}(u_i v_j) = i \times j \times s_G(u, v)$.

Lemma 3 ([2]) *Let G and H be two 2-edge-colored graphs. The graph G admits a homomorphism to $\rho(H)$ if and only if it admits a switching homomorphism to H .*

In other words, if a 2-edge-colored graph admits a homomorphism to an antitwinned target graph on n vertices, then it also admits a switching homomorphism to a target graph on $\frac{n}{2}$ vertices. The family $\rho(SP_q)$ also are interesting target graphs (especially for bounding the switching chromatic number since they are antitwinned).

Lemma 4 ([7]) *The graph $\rho(SP_q)$ is vertex-transitive, antiautomorphic, and has properties $P_{1, q-1}$, $P_{2, \frac{q-3}{2}}$, and $P_{3, \max(\frac{q-9}{4}, 0)}$.*

Let SP_q^+ be SP_q with an additional vertex that is connected to every other vertex with a positive edge. The Tromp-Paley graph $TR(SP_q)$ corresponds to $\rho(SP_q^+)$. This construction improves the properties of $\rho(SP_q)$ at the cost of having two more vertices. Since Tromp-Paley graphs are antitwinned, they are interesting for bounding the switching chromatic number.

Lemma 5 ([7]) *$TR(SP_q)$ is vertex-transitive, edge-transitive, antiautomorphic, and has properties $P_{1, q}$, $P_{2, \frac{q-1}{2}}$, and $P_{3, \frac{q-5}{4}}$.*

Bensmail et al. [1] recently proved that every 2-edge-colored graph with maximum degree 3 except the all positive and all negative K_4 admits a homomorphism to $TR(SP_5)$, hence $\chi_2(\mathcal{D}_3^c) \leq 12$, and $\chi_s(\mathcal{D}_3^c) \leq 6$ by Lemma 3. In the non-connected case, we can easily get $\chi_2(\mathcal{D}_3) \leq 14$ and thus $\chi_s(\mathcal{D}_3) \leq 7$ by Lemma 3 (it is possible to create an all positive K_4 and an all negative K_4 in $TR(SP_5)$ by adding two vertices). Their proof uses a computer to show that a minimal counter-example cannot contain some configurations and then concludes by using the properties of $TR(SP_5)$. Theorem 1 improves the upper bound of 14 to 11.

Let us give a sketch of proof of the first result of Theorem 1, namely $\chi_2(\mathcal{D}_3) \leq 11$.

Consider the graph SP_9^* obtained from SP_9 by adding two new vertices $0'$ and $1'$ as follows. Take the two vertices 0 and 1 of SP_9 (note that $s(01) = +1$), and link $0'$ and $1'$ to the vertices of SP_9 in the same way as 0 and 1 are, respectively; add an edge $0'1'$ with $s(0'1') = -1$; finally we add edges $00'$ and $11'$ with $s(00') = -1$ and $s(11') = +1$. We will prove that every graph from \mathcal{D}_3 admits a homomorphism to SP_9^* .

We first show that every connected 2-degenerate 2-edge-colored graph with maximum degree 3 admits a homomorphism to SP_9 by using its structural properties given by Lemma 2 (a unique exception exists and is separately treated).

Let G be a connected 3-regular 2-edge-colored graph. If G is all positive, then we color it using an all positive K_4 that SP_9^* contains as a subgraph. Assume now that G is not all positive. Let uv be a negative edge of G . We remove uv from G to create a new graph G' . Graph G' is 2-degenerate so it admits a homomorphism φ' to SP_9 . If $s(\varphi'(u)\varphi'(v)) = -1$, then φ' is also a homomorphism from G to SP_9 .

If $s(\varphi'(u)\varphi'(v)) = +1$, then by edge-transitivity of SP_9 we can recolor the vertices of G' such that $\varphi'(u) = 0$ and $\varphi'(v) = 1$. We can then extend φ' to a homomorphism φ of G to SP_9^* by recoloring u and v such that $\varphi(u) = 0'$ and $\varphi(v) = 1'$ since $s(0'1') = -1$.

Finally, if $\varphi'(u) = \varphi'(v)$, then by vertex-transitivity of SP_9 we can recolor the vertices of G' such that $\varphi'(u) = \varphi'(v) = 0$. We can then extend φ' to a homomorphism φ of G to SP_9^* by recoloring v such that $\varphi(v) = 0'$ since $s(00') = -1$.

We have proven that every graph in \mathcal{D}_3^c admits a homomorphism to SP_9^* which means that SP_9^* is universal for \mathcal{D}_3 . This concludes the proof.

To prove the two other upper bounds of Theorem 1, we use the same method on target graphs SP_{29} and $TR(SP_{13})$.

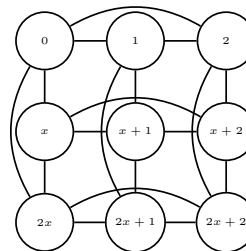

Figure 3: The graph SP_9 , non-edges are negative edges

References

- [1] J. Bensmail, T. Pierron, É. Sopena. Personnal communication, 2019.
- [2] R. C. Brewster, T. Graves. Edge-switching homomorphisms of edge-coloured graphs. In **Discrete Mathematics** 309(18):5540-5546, 2009.
- [3] B. Courcelle. The monadic second order-logic of graphs VI : on several representations of graphs by relational structures. In **Discrete Applied Mathematics** 54:117-149, 1994.
- [4] S. Das, S. Nandi, S. Sen. On chromatic number of colored mixed graphs. In **Conf. on Algorithms and Discrete Applied Mathematics** 130-140, 2017.
- [5] B. Guenin. Packing odd circuit covers: A conjecture. Manuscript, 2005.
- [6] R. Naserasr, E. Rollova, and É. Sopena. Homomorphisms of signed graphs. In **Journal of Graph Theory** 79(3):178-212, 2015.
- [7] P. Ochem, A. Pinlou, S. Sen. Homomorphisms of 2-edge-colored triangle-free planar graphs. In **Journal of Graph Theory** 85(1):258-277, 2017.

On the 4-color theorem for signed graphs

František Kardoš and Jonathan Narboni

LaBRI, University of Bordeaux, France

EXTENDED ABSTRACT

All graphs in this paper are finite, simple undirected graphs. Let G be a graph and $\sigma : E(G) \rightarrow \{-1, +1\}$ be a mapping. The pair (G, σ) is called a *signed graph*, σ is called the *signature* of the graph, and G the *underlying graph*. If e is an edge of G , $\sigma(e)$ is called the *sign* of e . For convenience, when there is no ambiguities, we only write G to denote the signed graph. Let (G, σ) be a signed graph, and let v be a vertex of G . *Switching* the vertex v in G consists in switching the sign of every edge incident to v .

Máčajová, Raspaud and Škoviera [1] defined a k -signed coloring of a signed graph G as a mapping:

$$\begin{aligned} c : V(G) &\rightarrow \{-k/2, \dots, -1, 1, \dots, k/2\} && \text{if } k \equiv 0 \pmod{2}, \text{ or} \\ c : V(G) &\rightarrow \{-(k-1)/2, \dots, -1, 0, 1, \dots, (k-1)/2\} && \text{otherwise,} \end{aligned}$$

s.t. $\forall uv \in E(G)$, $c(u) \neq \sigma(uv) \cdot c(v)$. The signed chromatic number of a graph $\chi(G)$ is defined in a natural way, $\chi(G) = \min\{k : G \text{ has a } k\text{-signed coloring}\}$.

This definition is compatible with the switch operation. In order to preserve a k -signed coloring c of a graph G when switching a vertex v of G , it suffices to switch the sign of the color $c(v)$.

Máčajová, Raspaud and Škoviera conjectured that the Four Color Theorem holds for the signed planar graphs as well :

Conjecture 1 [1] *Let G be a simple signed planar graph. Then $\chi(G) \leq 4$.*

We prove here that Conjecture 1 does not hold.

Before introducing a counterexample to Conjecture 1, we translate the question of vertex-coloring of a signed planar graph to a question of edge-labeling of its dual. We extend this way the reduction from 4-coloring of a triangulation to 3-edge-coloring of the dual used in the proof of the four-color theorem (see [2]).

Let G be a 3-connected signed planar graph, and let f be a face of G . We call the face f positive (negative) if the facial cycle of f contains an even (odd, respectively) number of negative edges.

Let G^* be the dual graph of G . We call the vertices of G^* corresponding to the positive faces of G *positive*, and the vertices corresponding to the negative face of G *negative*.

Observe that in a signed planar graph G there is always an even number of negative faces, and that the set of negative faces is invariant with respect to switching, so signature of the vertices of the dual graph G^* is the same for every graph G belonging to a same switch equivalence class.

Let H be a 3-connected planar graph and let c be a $\{0, a, b\}$ -edge-labeling of H . We denote $d_x(v)$ the number of edges incident to v labelled x for $v \in V(H)$ and $x \in \{0, a, b\}$.

Definition 2 *Let H be a 3-connected planar graph with an even number of negative vertices and let c be a $\{0, a, b\}$ -edge-labeling of H . The labeling c is a weak signed edge-labeling of H if*

- (i) $d_0(v) \equiv d_H(v) \pmod{2}$, and
- (ii.a) $d_a(v) \equiv d_b(v) \equiv d_H(v) \pmod{2}$ if v is a positive vertex, or
- (ii.b) $d_a(v) \equiv d_b(v) \equiv d_H(v) + 1 \pmod{2}$ if v is a negative vertex.

In particular, if H is a cubic graph with an even number of negative vertices (H corresponds to the dual of a signed triangulation), then a weak signed edge-labeling of H is a $\{0, a, b\}$ -edge-labeling of H such that

- if v is positive, then it is incident to one edge of each label from $\{0, a, b\}$,
- if v is negative, then it is incident to one edge labelled 0, and the two other edges have the same label $c \in \{0, a, b\}$.

Conjecture 3 *Let H be a 3-connected planar graph with an even number of negative vertices. Then there exists a weak signed edge-labeling of H .*

Theorem 4 *Conjectures 1 and 3 are equivalent.*

Proof. The principle of the reduction is the same as in the proof of 4CT [2]. If G is a signed graph, given a 4-signed coloring c of G , a labeling φ^* of G^* is constructed such that if e^* is an edge of G^* corresponding to an edge $e = uv$ of G , the label $\varphi^*(e^*)$ corresponds to the involutive permutation ψ of the set of colors $\{1, 2, -1, -2\}$ such that $\psi(c(u)) = c(v)$. More precisely, the labeling is defined by the following formula:

$$\varphi^*(e^*) = \begin{cases} 0 & \text{if } c(u) = -\sigma(uv) \cdot c(v), \\ a & \text{if } \sigma(uv) \cdot c(u) \cdot c(v) = 2, \\ b & \text{if } \sigma(uv) \cdot c(u) \cdot c(v) = -2. \end{cases} \quad (1)$$

The fact that c is a signed-coloring of G guarantees that (i), (ii.a), and (ii.b) hold.

Conversely, given a weak-labeling φ^* of G^* , let T be a spanning tree of G rooted at r , and let $c(r) = 1$. For each vertex u of G , with father v in T , and $uv = e$, let

$$c(u) = \begin{cases} \sigma(e) \cdot (\sigma(c(v)) \cdot 3 - c(v)) & \text{if } \varphi^*(e^*) = a, \\ -\sigma(e) \cdot (\sigma(c(v)) \cdot 3 - c(v)) & \text{if } \varphi^*(e^*) = b, \\ -\sigma(e) \cdot \varphi(v) & \text{if } \varphi^*(e^*) = 0. \end{cases} \quad (2)$$

It is not difficult to check that the coloring c defined this way is indeed a signed-coloring of G . □

Definition 5 *Let H be a 3-connected planar graph with an even number of negative vertices. A $\{0, a, b\}$ -edge-labeling c of H is a strong signed edge-labeling if*

- (i) c is a weak signed edge-labeling of H , and
- (ii) $d_0(v) < d_H(v)$ for every odd-degree vertex v of H .

Observe that $d_0(v) = d_H(v)$ is possible only if v is a negative vertex of odd degree.

Conjecture 6 *Let H be a 3-connected planar graph with an even number of negative vertices. Then there exists a strong signed edge-labeling of H .*

Theorem 7 *Conjectures 3 and 6 are equivalent.*

Proof. Trivially, Conjecture 6 implies Conjecture 3.

Conversely, assume Conjecture 3. We define W_k as the graph obtained from a cycle of length $2k$ with every other vertex negative by adding a pending edge to each positive vertex of the cycle, and by adding a positive vertex adjacent to each negative vertex of the cycle (see Figure 1 for illustration). Let H' be the graph obtained from H by replacing every negative odd vertex v by $W_{d(v)}$.

In order to prove that any weak labeling of H' can be reduced to a strong labeling of H , it suffices to observe that for a weak labeling of H' and for every copy of the gadget W_k , the outgoing edges of W_k cannot all be labeled 0. □

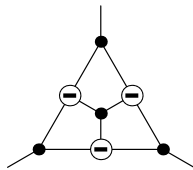

Figure 1: An example of a gadget used to replace an odd negative vertex (here $k = 3$).

Corollary 8 *Let H be a cubic 3-connected planar graph with an even number of negative vertices. H has a strong signed edge-labeling if and only if H has a 2-factor F such that every cycle of F has an even number of positive vertices.*

If H admits such a 2-factor F , we call F a *consistent 2-factor*.

Lemma 9 *Let H be a cubic 3-connected planar graph with an even number of negative vertices, containing a Tutte's fragment T_0 attached by the edges e_1, e_2, e_3 , as depicted in Figure 2. Then every consistent 2-factor of H contains the edge e_1 .*

Proof. Let F be a consistent 2-factor of H that does not contain e_1 . Then the edges $e_2, e_3, e_4, e_5, e_9, e_{14}, e_{15}, e_{17}$ and e_{21} are in F unless there is a short cycle with an odd number of positive vertices in F . Further detailed case analysis shows that there is always a cycle in F with an odd number of positive vertices, a contradiction. \square

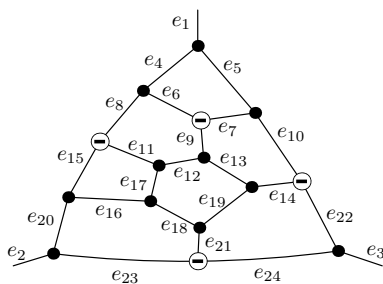

Figure 2: The Tutte's fragment.

Theorem 10 *There exists a set of twelve vertices of the Tutte's graph T to be chosen negative such that T does not have a consistent 2-factor.*

Proof. Let the negative vertices of T be chosen as in Figure 3. Assume that H has a consistent 2-factor F .

The graph T can be viewed as a K_4 where three of the four vertices were replaced by the Tutte's fragment. By Lemma 9, all the three edges incident to the central vertex belong to F , a contradiction. \square

Corollary 11 *Conjecture 1 is false.*

To find a counterexample, it suffices to consider the Tutte's graph T with a choice of negative vertices as depicted in Figure 3 (left) and replace every negative vertex by the graph W_3 depicted in Figure 1, and then take the dual. This gives a signed triangulation on 61 vertices (see Figure 3 (right)).

We do not claim that the counterexample to Conjecture 1 described above is minimal ; finding a smallest one is still an open question.

However, if a graph is hamiltonian, then it has a consistent 2-factor (one of its hamiltonian cycle); therefore, a minimum counterexample to Conjecture 6 can be easily deduced from a

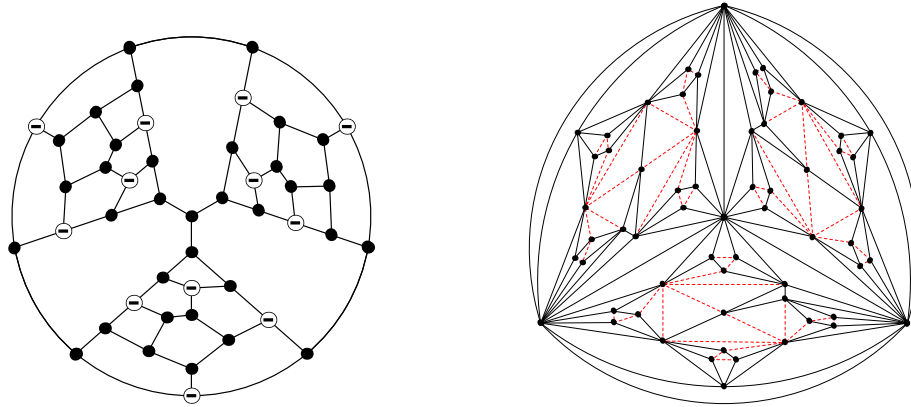

Figure 3: The Tutte's graph with a choice of negative vertex such that there is no consistent 2-factor (left); the corresponding signed triangulation, with negative edges denoted by the dashed red lines (right).

minimum non-hamiltonian cubic 3-connected planar graph (see [3]): Such a graph (see Figure 4) is constructed from a pentagonal prism with two negative vertices, and where two vertices are replaced by a Tutte's fragment (the triangles in Figure 4, with e_1 attached to the vertex of the inner cycle) with the same choice of negative vertices as in Figure 2. This graph has 38 vertices; the corresponding planar triangulation obtained by replacing a subset of negative vertices by gadgets has 39 vertices, see Figure 4, right.

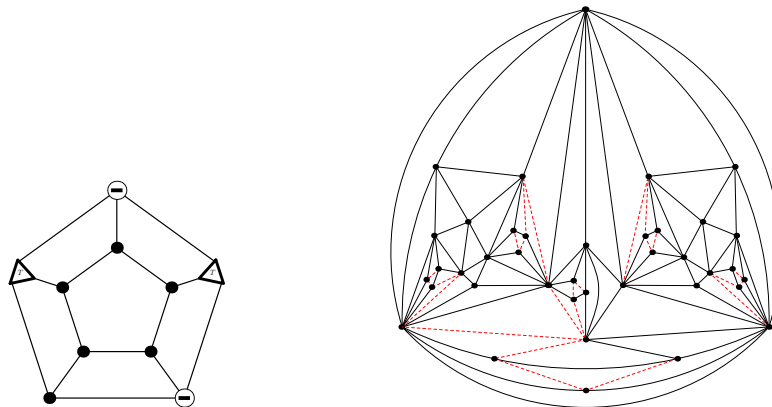

Figure 4: A minimum non-hamiltonian cubic 3-connected planar graph with a choice of negative vertices such that there is no consistent 2-factor (left); the smallest counterexample to Conjecture 1 we are aware of so far (right).

References

- [1] E. Máčajová, A. Raspaud, M. Škoviera. The Chromatic Number of a Signed Graph. In **Electron. J. Comb.** 23(1):1–14, 2016.
- [2] N. Robertson, D. Sanders, P. Seymour, R. Thomas. The four-colour theorem. In **J. Comb. Theory B** 70(1):2–44, 1997.
- [3] D. Holton, B. McKay. The smallest non-hamiltonian 3-connected cubic planar graphs have 38 vertices. In **J. Comb. Theory B** 45(3):305–319, 1988.

Automorphism groups of planar and nonplanar maps in linear time

Ken-ichi Kawarabayashi¹, Bojan Mohar², Roman Nedela³, and Peter Zeman⁴

¹ National Institute of Informatics, Tokyo, Japan

² Department of Mathematics, Simon Fraser University, Burnaby, Canada

³ Department of Mathematics, Faculty of Applied Sciences, University of West Bohemia, Pilsen, Czech Republic

⁴ Department of Applied Mathematics, Faculty of Mathematics and Physics, Charles University, Prague, Czech Republic

EXTENDED ABSTRACT

Introduction. By a *topological map* we mean a 2-cell decomposition of a closed compact surface, i.e., an embedding of a graph into a surface such that every face is homeomorphic to an open disc. An automorphism of a map is a permutation of the vertices which preserves the vertex-edge-face incidences. In this paper, we study symmetries of maps, which are captured by their automorphism groups. Topologically, we can think about symmetries of maps as symmetries of the underlying surface. For example, if the underlying surface is orientable, then every map automorphism induces an automorphism of the surface, i.e., a conformal homeomorphism of the surface into itself.

To every map there is a corresponding action of a discrete group on its underlying surface. Moreover, every finite group appears as a discrete group of automorphisms of a closed compact surface. Conversely, every finite group of automorphisms of a surface is a group of automorphisms of some map. Therefore, studying automorphisms groups of maps is equivalent to studying finite groups of automorphisms of surfaces. This motivates the study of the automorphism groups of maps from the computational point of view. Our main results reads as follows.

Theorem 1 *For a map M on a surface of genus g , generators of the automorphism group of M can be found in time $f(g)\|M\|$, where $f(g)$ is some computable function and $\|M\|$ is the size of the map.*

This has been investigated for a long time. Whitney's theorem [17] states that 3-connected planar graphs have (combinatorially) unique embeddings in the sphere. A consequence is that the isomorphism problem for 3-connected planar graphs is equivalent to the isomorphism problem of spherical maps. Hopcroft and Wong [5] solved the isomorphism problem for 3-connected planar graphs in linear time and a part of our approach is based on their algorithm. They show that every 3-connected spherical map must have an applicable isomorphism-preserving reduction, or it is one of irreducible maps, for which they solve the problem by a special algorithm.

Automorphism groups of 3-connected planar graphs are well-understood, they are exactly the spherical groups, i.e., finite subgroups of the group of 3×3 orthogonal matrices. However, it is not obvious how to modify the algorithm of Hopcroft and Wong [5] to compute the generators of the automorphism group. In fact, Colbourn and Booth [3] posed this as an open problem. Theorem 1 solves this in much greater generality and our approach provides also several new insights into the algorithm of Hopcroft and Wong [5].

Another motivation stems from the study of the graph isomorphism problem, which is one of the most fundamental problems in theoretical computer science and discrete mathematics. Many algebraic, combinatorial, and topological structures can be encoded by (possibly infinite) graphs, while preserving the automorphism group [13]. The graph isomorphism problem is therefore of a special importance. Also, in complexity theory, it is the prime candidate problem to be between between P and NP-complete problems. If the graph isomorphism was NP-complete, then would the polynomial-time hierarchy collapse to its second level [14]. This is considered to be an evidence for the contrary. The problem is polynomial-time equivalent

to the problem of computing the generators of the automorphism group [10]. Currently, the best upper bound for the complexity of these problems is due to Babai [1]. By fixing some natural parameters, it is often possible to obtain a polynomial-time algorithm for some restricted classes of graphs, e.g, graphs of bounded degree [9, 4], eigenvalue multiplicity [2], treewidth [8], etc.

Every graph can be embedded into a surface of sufficiently large genus, which also provides an important parametrization of all graphs. The first polynomial-time algorithm testing isomorphism of bounded genus graphs was given by Miller [11]. Only recently, a linear-time algorithm was announced [7]. This already implies that the generators of the automorphism group of a graph of bounded genus can be computed in polynomial time, however, an interesting question, which remained open, is whether linear time can be achieved here as well. The first unavoidable step is to show that for a map M on a fixed surface of genus g it is possible to compute the automorphism group in linear time, which is our main result.

Oriented maps. In our algorithm, we first deal with the oriented maps on orientable surfaces. Formally, a *combinatorial oriented map* is any triple $M = (D, R, L)$, where D is a finite non-empty set of *darts*, R is any permutation of darts, L is a fixed-point-free involution of D , and the group $\langle R, L \rangle \leq \text{Sym}(D)$ is transitive on D . The vertices, edges, and faces of M are in one-to-one correspondence with the cycles of R , L , $R^{-1}L$, respectively. We define $\|M\| = |D|$.

Two oriented maps $M_1 = (D_1, R_1, L_1)$ and $M_2 = (D_2, R_2, L_2)$ are *isomorphic*, in symbols $M_1 \cong M_2$, if there exists a bijection $\psi: D_1 \rightarrow D_2$, called an (*orientation-preserving*) *isomorphism* from M_1 to M_2 , such that $\psi R_1 = R_2 \psi$ and $\psi L_1 = L_2 \psi$. The *set of all (orientation-preserving) isomorphisms* from M_1 to M_2 is denoted by $\text{Iso}^+(M_1, M_2)$. The (*orientation-preserving*) *automorphism group* of M is the set $\text{Iso}^+(M, M)$, and we denote it by $\text{Aut}^+(M)$. Algebraically, $\text{Aut}^+(M)$ is just the *centralizer* of $\langle R, L \rangle$ in $\text{Sym}(D)$. Note that $\text{Aut}^+(M)$ acts semiregularly on the set of darts D .

We give a set of elementary reductions defined on labeled oriented maps, given by a quadruple (D, R, L, ℓ) , where ℓ is a labeling of D . The output of each elementary reduction is always a quadruple (D', R', L', ℓ') , satisfying $D' \subseteq D$, $|V(M')| + |E(M')| < |V(M)| + |E(M)|$, and $\text{Aut}^+(M') = \text{Aut}^+(M)$. Here the automorphism groups of M and M' are considered to be label-preserving. The purpose of the labelings is to ensure that the automorphism group does not grow after an elementary reduction. The implementation of the labelings is crucial for the proof that the algorithm runs in linear time. All the elementary reductions are ordered according to a priority. At every step, the reduction with the highest possible priority is applied.

Informally, these reductions proceed as follows. The highest priority has the *deletion of faces of degree 1 and 2*. If a map has no faces of degree 1 and 2, it is *face-normal*, and by the Euler's formula, the minimum degree of a vertex is at most $6(1 - \chi)$, where χ is the Euler-Poincaré characteristic of the underlying surface S . Note that χ can be expressed as a function of the genus of S . Vertices of degree at most $6(1 - \chi)$ are called *light*. Next, is the *contraction of edges incident to light vertices*. The edges to be contracted are canonically chosen according to certain well-defined rules. Finally, there is the *replacement of a light vertex by a face* which is applied if there is no canonical choice of the contractible edges.

If none of the reductions apply, the map is a *uniform oriented map* U , i.e., a map which has the same cyclic vector of face sizes, called *local type*, at every vertex. Since the darts of U form a subset of the darts of M , by semiregularity, every generator of $\text{Aut}^+(U)$ can be extended to a generator of $\text{Aut}^+(M)$ in linear time.

Uniform oriented maps. If the genus of the underlying surface is at least $g = 2$, then from Euler's formula it follows that the number of uniform maps is bounded by a function of g . To compute the generators of the automorphism group, a brute-force approach is sufficient. The same works for sporadic uniform spherical maps which consist of the following: the 5 Platonic solids, the 13 Archimedean solids, and the pseudo-rhombicuboctahedron.

The infinite classes of spherical maps are cycles, dipoles, prisms, and antiprisms, all of

which we reduce the first case. Finally, the infinite classes of uniform toroidal maps are those with the local types in the following list [6]: $(3, 3, 3, 3, 3, 3)$, $(4, 4, 4, 4)$, $(6, 6, 6)$, $2 \times (3, 3, 3, 3, 6)$, $(3, 3, 3, 4, 4)$, $(3, 3, 4, 3, 4)$, $(3, 4, 6, 4)$, $(3, 6, 3, 6)$, $(3, 12, 12)$, $(4, 6, 12)$, and $(4, 8, 8)$. One type occurs two times, once as a mirror image of the other. Here all of them are reduced to the first two cases.

Non-oriented maps. Let N be a map on any, possibly non-orientable, surface. In general, a *combinatorial non-oriented map* is a quadruple (F, λ, ρ, τ) , where F is a finite non-empty set of *flags*, and $\lambda, \rho, \tau \in \text{Sym}(F)$ are fixed-point-free involutions such that $\lambda\tau = \tau\lambda$ and the group $\langle \lambda, \rho, \tau \rangle$ acts transitively on F . We define $\|N\| = |F|$.

Each flag corresponds uniquely to a vertex-edge-face incidence triple (v, e, f) . Geometrically, it can be viewed as the triangle defined by v , the center of e , and the center f . The vertices, edges, and faces of N correspond uniquely to the orbits of $\langle \rho, \tau \rangle$, $\langle \lambda, \tau \rangle$, and $\langle \rho, \lambda \rangle$, respectively. An *isomorphism* of two non-oriented maps N_1 and N_2 is a bijection $\psi: F \rightarrow F$ which commutes with λ, ρ, τ .

The even-word subgroup $\langle \rho\tau, \tau\lambda \rangle$ has index at most two in $\langle \lambda, \rho, \tau \rangle$. If it is exactly two, the map N is called *orientable*. For every oriented map (D, R, L) it is possible to construct the corresponding non-oriented map (F, λ, ρ, τ) . Conversely, from an orientable non-oriented map (F, λ, ρ, τ) it is possible to construct two oriented maps $M = (D, R, L)$ and $M^{-1} = (D, R^{-1}, L)$. The map M^{-1} is called the *mirror image* of M . An *orientation-reversing automorphism* of M is a mapping $\varphi \in \text{Iso}^+(M, M^{-1})$ and M is called *reflexible* if $\text{Iso}^+(M, M^{-1})$ is non-empty. The *full automorphism group* of M , denoted by $\text{Aut}(M)$, is generated by $\text{Aut}^+(M)$ and an arbitrary $\varphi \in \text{Iso}^+(M, M^{-1})$.

For a non-oriented map $N = (F, \lambda, \rho, \tau)$, it is possible to test in linear time if N is orientable [15, 16]. The *barycentric subdivision* B of N is constructed by placing a new vertex in the center of every edge and face, and then joining the centers of faces with the incident vertices and with the center of the incident edges. The dual of B is 3-valent map, i.e., every vertex is of degree 3. Then N is orientable if and only if the underlying 3-valent graph of the dual of the barycentric subdivision of N is bipartite.

If the input non-oriented map $N = (F, \lambda, \rho, \tau)$ is orientable, we compute its Euler-Poincaré characteristic, and construct M and M^{-1} . Using the algorithm for oriented maps, we compute the generators of $\text{Aut}^+(M)$ and find an arbitrary $\varphi \in \text{Iso}^+(M, M^{-1})$.

If N is non-orientable, we reduce the problem of computing the generators of $\text{Aut}(N)$ to the problem of computing the generators of $\text{Aut}^+(\tilde{N})$, for some orientable map \tilde{N} . In particular, the map \tilde{N} is the antipodal double cover of M .

Given a map $N = (F, \lambda, \rho, \tau)$ on a non-orientable surface of genus γ , we define the antipodal double cover $\tilde{N} = (D, R, L)$ by setting $D := F$, $R := \rho\tau$, and $L := \tau\lambda$. Since N is non-orientable, we have $\langle R, L \rangle = \langle \lambda, \rho, \tau \rangle$, so $\langle R, L \rangle$ is transitive and \tilde{N} is well-defined. For more details on this construction see [12]. We note that $\tilde{\chi} = 2\chi$, where $\tilde{\chi}$ and χ is the Euler-Poincaré characteristic of the underlying surface of \tilde{N} and N , respectively.

We show that $\text{Aut}(N) = \{\varphi \in \text{Aut}^+(\tilde{N}) : \varphi\tau = \tau\varphi\}$. If the non-orientable genus γ of the underlying surface S of N is at least 2, then the orientable genus g of the underlying surface of \tilde{N} is also at least 2. By the Riemann-Hurwitz theorem, the order of $\text{Aut}^+(\tilde{N})$ is bounded by a function of g , and a brute-force approach is sufficient to find $\text{Aut}(N)$. If S is the projective plane or the Klein bottle, then the underlying surface of \tilde{N} is the sphere or the torus, respectively. For these we give linear-time algorithms to compute the generators of the group $\text{Aut}(N)$.

References

- [1] László Babai. Graph isomorphism in quasipolynomial time. In *Proceedings of the forty-eighth annual ACM symposium on Theory of Computing*, pages 684–697. ACM, 2016.

- [2] László Babai, D Yu Grigoryev, and David M Mount. Isomorphism of graphs with bounded eigenvalue multiplicity. In *Proceedings of the fourteenth annual ACM symposium on Theory of computing*, pages 310–324. ACM, 1982.
- [3] Charles J Colbourn and Kellogg S Booth. Linear time automorphism algorithms for trees, interval graphs, and planar graphs. *SIAM Journal on Computing*, 10(1):203–225, 1981.
- [4] Martin Grohe, Daniel Neuen, and Pascal Schweitzer. A faster isomorphism test for graphs of small degree. In *2018 IEEE 59th Annual Symposium on Foundations of Computer Science (FOCS)*, pages 89–100. IEEE, 2018.
- [5] J. E. Hopcroft and J. K. Wong. Linear time algorithm for isomorphism on planar graphs. In *Proc. 6th Annual ACM Symp. on Theory of Computing.*, 1974.
- [6] Branko Grünbaum and Geoffrey Colin Shephard. *Tilings and patterns*. Freeman, 1987.
- [7] Ken-ichi Kawarabayashi. Graph isomorphism for bounded genus graphs in linear time. *arXiv preprint arXiv:1511.02460*, 2015.
- [8] Daniel Lokshtanov, Marcin Pilipczuk, Michał Pilipczuk, and Saket Saurabh. Fixed-parameter tractable canonization and isomorphism test for graphs of bounded treewidth. *SIAM Journal on Computing*, 46(1):161–189, 2017.
- [9] Eugene M. Luks. Isomorphism of graphs of bounded valence can be tested in polynomial time. *Journal of computer and system sciences*, 25(1):42–65, 1982.
- [10] Rudolf Mathon. A note on the graph isomorphism counting problem. *Information Processing Letters*, 8(3):131–136, 1979.
- [11] Gary Miller. Isomorphism testing for graphs of bounded genus. In *Proceedings of the twelfth annual ACM symposium on Theory of computing*, pages 225–235. ACM, 1980.
- [12] Roman Nedela, and Martin Škoviera. Exponents of orientable maps. *Proceedings of the London Mathematical Society*, 75(1):1–31, 1997.
- [13] Aleš Pultr and Věra Trnková. *Combinatorial, algebraic and topological representations of groups, semigroups and categories*, volume 1980. Prague, 1980.
- [14] Uwe Schöning. Graph isomorphism is in the low hierarchy. *Journal of Computer and System Sciences*, 37(3):312–323, 1988.
- [15] Jonathan L Gross and Thomas W Tucker. *Topological graph theory*. Courier Corporation, 2001.
- [16] Bojan Mohar and Carsten Thomassen. *Graphs on surfaces*, volume 10. JHU Press, 2001.
- [17] Hassler Whitney. 2-isomorphic graphs. *American Journal of Mathematics*, 55(1):245–254, 1933.

Upper Traceable Number of Circulant and Generalized Petersen Graphs

Laila Loudiki and Mustapha Kchikech

Cadi Ayyad university, Polydisciplinary faculty of Safi,
LMC Laboratory, B.P.4162, Sidi Bouzid, Safi, Morocco

EXTENDED ABSTRACT

We consider only simple undirected connected graphs with no loops or multiple edges. Let G be a graph with vertex set $V(G)$ and edge set $E(G)$. The distance $d_G(x, y)$ between any pair of vertices x, y is the length of the shortest path between them. The diameter of a graph is denoted by $D(G)$ and defined as the maximum distance between any two vertices, i.e., $D(G) = \max\{d_G(x, y); x, y \in G\}$.

For a graph G of order n and for a linear ordering $s : (x_1, x_2, \dots, x_n)$ of its vertices, let $d(s) = \sum_{i=1}^{n-1} d_G(x_i, x_{i+1})$. The *upper traceable number* of G , denoted $t^+(G)$, is $t^+(G) = \max d_G(s)$, where the maximum is taken over all linear orderings s of vertices of G ([1, 2, 5, 6, 7]).

Due to their regular structure, generalized Petersen graphs are commonly used in interconnection networks. This class of graphs was first introduced by Coxeter [2] in 1950 and defined by Watkins [3] as follows: for a given integers n and $k < \frac{n}{2}$, we can define a generalized Petersen graph $GPG(n, k)$ as a graph on vertex-set $\{u_0, \dots, u_{n-1}, v_0, \dots, v_{n-1}\}$. The edge-set may be naturally partitioned into three equal parts (note that all subscripts are assumed modulo n): the edges $E_O(n, k) = \{u_i u_{i+1}\}_{i=0}^{n-1}$ from the *outer rims*, inducing a cycle of length n ; the edges $E_I(n, k) = \{v_i v_{i+k}\}_{i=0}^{n-1}$ from the *inner rims*, inducing $\gcd(n, k)$ cycles of length $\frac{n}{\gcd(n, k)}$; and the edges $E_S(n, k) = \{u_i v_i\}_{i=0}^{n-1}$, also called *spokes*, that induce a perfect matching in $GPG(n, k)$. Hence the edge-set may be defined as $E(G(n, k)) = E_O(n, k) \cup E_I(n, k) \cup E_S(n, k)$.

Following the notation of Beenker and Van Lint [4], the circulant graph $C_n(a_1, a_2)$ is defined to be the graph on the vertices $0, 1, \dots, n-1$ with vertex i adjacent to the vertices $i \pm a_1$ and $i \pm a_2$, where the calculations are performed modulo n .

In this paper, we investigate $t^+(C_n(1, k))$ and $t^+(GPG(n, k))$ for several values of n and k . For that, we first establish a classification for the diameter of generalized Petersen graphs $D(GPG(n, k))$ in terms of the diameter of circulant graphs $D(C_n(1, k))$. Then, we provide exact values for both $D(GPG(n, k))$ and $D(C_n(1, k))$, for several values of n and k , as well as an upper bound for $D(GPG(n, k))$ for all n and k . Finally, we show exact values of the upper traceable number for both circulant and generalized Petersen graphs for several cases of n and k . Then, we give an upper and lower bound of the same for generalized Petersen graphs.

Proofs left out in this note will appear in the full version of the paper.

1 Diameter of generalized Petersen graphs

In [4], Beenker and Van Lint revealed a natural relation between the generalized Petersen graph $GPG(n, k)$ and the circulant graph $C_n(1, k)$. The circulant graph $C_n(1, k)$ can be obtained from $GPG(n, k)$ by contracting the vertices u_i and v_i for $0 \leq i \leq n-1$; by a reversed procedure $GPG(n, k)$ can be obtained from $C_n(1, k)$. Beenker and Van Lint [4] proved that $D(GPG(n, k)) = D(C_n(1, k)) + \epsilon$ with $\epsilon \in \{1, 2\}$. The following theorem gives away the classes of $GPG(n, k)$ in which $D(GPG(n, k)) = D(C_n(1, k)) + 1$ and the others in which $D(GPG(n, k)) = D(C_n(1, k)) + 2$.

Theorem 1

$$D(GPG(n, k)) = \begin{cases} D(C_n(1, k)) + 1 & \text{if } n = 4p \text{ and } k = 2p - 1 \text{ with } p > 2, \\ D(C_n(1, k)) + 2 & \text{otherwise.} \end{cases}$$

Despite of the symmetric structure of $C_n(1, k)$, the exact value of its diameter for all n and k is not been determined yet. Next, we give the path class of $C_n(1, k)$ and we define the notion of distance in $C_n(1, k)$ for all values of n and k .

Theorem 2 *Let n, k and j be tree integers with $1 \leq j < k$ and $k \leq \lfloor \frac{n}{2} \rfloor, k \neq \frac{n}{2}$. Let i be a vertex of the graph $C_n(1, k)$. Any path leading from 0 to i in $C_n(1, k)$ belongs to the path class of lengths l equals, in each of the following cases, to*

1. $i \equiv r_1 \pmod k$:
 - $l_1 = r_1 + \lfloor \frac{i}{k} \rfloor$,
 - $l_2 = 1 + k - r_1 + \lfloor \frac{i}{k} \rfloor$.
2. $jn + i \equiv r_2^j \pmod k$:
 - $l_3^j = r_2^j + \lfloor \frac{jn+i}{k} \rfloor$,
 - $l_4^j = 1 + k - r_2^j + \lfloor \frac{jn+i}{k} \rfloor$.
3. $jn - i \equiv r_3^j \pmod k$:
 - $l_5^j = r_3^j + \lfloor \frac{jn-i}{k} \rfloor$,
 - $l_6^j = 1 + k - r_3^j + \lfloor \frac{jn-i}{k} \rfloor$.

Theorem 3 *Let n, k and j be tree integers with $1 \leq j < k$ and $k \leq \lfloor \frac{n}{2} \rfloor, k \neq \frac{n}{2}$. For every vertex i of $C_n(1, k)$, the distance between 0 and i is equal to*

$$d_{C_n(1, k)}(0, i) = \min(l_1, l_2, l_3^j, l_4^j, l_5^j, l_6^j).$$

In this section, we apply Theorem 1 to determine exact values for the diameter of $GPG(n, k)$ for several values of n and k . We also give an upper bound for the same for all n and k . Note that other exact values for the diameter of $GPG(n, k)$ will appear in the full version of the paper.

1.1 Diameter of $GPG(4p, 2p - 1)$ with $p > 2$

Theorem 4 *Let $p \geq 2$ be an integer. We have*

$$D(C_{4p}(1, 2p - 1)) = p.$$

Theorem 5 *Let $p > 2$ be an integer. We have*

$$D(GPG(4p, 2p - 1)) = p + 1.$$

1.2 Diameter of $GPG(n, 2)$

Theorem 6 *For all integers n and $p \geq 1$, we have*

$$D(C_n(1, 2)) = \begin{cases} p & \text{if } n = 4p \text{ or } n = 4p + 1, \\ p + 1 & \text{if } n = 4p + 2 \text{ or } n = 4p + 3. \end{cases}$$

Theorem 7 *For all integers n and $p \geq 1$, we have*

$$D(GPG(n, 2)) = \begin{cases} p + 2 & \text{if } n = 4p \text{ or } n = 4p + 1, \\ p + 3 & \text{if } n = 4p + 2 \text{ or } n = 4p + 3. \end{cases}$$

1.3 Diameter of $GPG(\alpha k, k)$, $k > 3$

Theorem 8 For all $n = \alpha k$ and all $k > 3$, we have

$$D(C_{\alpha k}(1, k)) = \lfloor \frac{\alpha}{2} \rfloor + \lfloor \frac{k}{2} \rfloor.$$

Theorem 9 For all $n = \alpha k$ and all $k > 3$, we have

$$D(GPG(\alpha k, k)) = \lfloor \frac{\alpha}{2} \rfloor + \lfloor \frac{k}{2} \rfloor + 2.$$

1.4 Upper bound for $D(GPG(n, k))$

Theorem 10 For all n and k , we have

$$D(C_n(1, k)) \leq \lfloor \frac{\lfloor \frac{n}{2} \rfloor}{k} \rfloor + \lceil \frac{k}{2} \rceil.$$

Theorem 11 For all n and k , we have

$$D(GPG(n, k)) \leq \lceil \frac{\lfloor \frac{n}{k} \rfloor}{2} \rceil + \lfloor \frac{k}{2} \rfloor + 2.$$

2 Upper traceable number of $GPG(n, k)$ and $C_n(1, k)$

In this section, we give exact values of the upper traceable number of both circulant and generalized Petersen graphs for several cases of n and k . Then, we show an upper and lower bound of the same number for generalized Petersen graphs.

2.1 Upper traceable number of $C_n(1, 2)$

Theorem 12 Let $p \geq 1$, an integer. We have

$$t^+(C_n(1, 2)) = \begin{cases} p(4p - 1) & \text{if } n = 4p, \\ 4p^2 & \text{if } n = 4p + 1 \text{ with } p \neq 3j, j \geq 1, \\ 2(2p^2 - 1) & \text{if } n = 4p + 1 \text{ with } p = 3j, j \geq 1, \\ (2p + 1)^2 - p & \text{if } n = 4p + 2, \\ 2(2p + 1)(p + 1) & \text{if } n = 4p + 3. \end{cases}$$

2.2 Upper traceable number of $C_{4p}(1, 2p - 1)$

Theorem 13 Let $p \geq 2$, an integer. We have

$$t^+(C_{4p}(1, 2p - 1)) = 3p^2 + (p - 1)^2.$$

2.3 Upper traceable number of $GPG(n, 2)$

Theorem 14 For n even, we have

$$t^+(GPG(n, 2)) = \begin{cases} 8p(p + 2) - (p + 3) & \text{if } n = 4p \text{ with } p \geq 3, \\ 8p(p + 3) - (p - 8) & \text{if } n = 4p + 2 \text{ with } p \geq 2. \end{cases}$$

2.4 Upper traceable number of $GPG(4p, 2p - 1)$

Theorem 15 *Let $p \geq 2$, even. We have*

$$t^+(GPG(4p, 2p - 1)) = (8p - 1)(p + 1).$$

Note that many other exact values for the upper traceable number of both circulant and generalized Petersen graphs will appear in the full version of the paper.

2.5 Upper and lower bound for $t^+(GPG(n, k))$

Theorem 16 *For $n \geq 14$, we have*

$$2t^+(C_n(1, k)) \leq t^+(GPG(n, k)) < 4t^+(C_n(1, k)).$$

References

- [1] F. Okamoto, La Crosse, P. Zhang, Kalamazoo. On Upper Traceable Numbers of Graphs. **Mathematica Bohemica**, No. 4, 389–405, 2008.
- [2] F. Okamoto et al.. The Upper Traceable Number of a Graph. **Czechoslovak Mathematical Journal**, 58 (133), 271–287, 2008.
- [3] M. E. Watkins. A Theorem on Tait Colorings with an Application to the Generalized Petersen Graphs. **Journal of Combinatorial Theory** 6, 152–164, 1969.
- [4] G. F. M. Beenker, J.H. Van Lint. Optimal generalized Petersen graphs. **Philips J. Res.**, 43:129–136, 1988.
- [5] V. Saenpholphat, F. Okamoto, P. Zhang. Measures of traceability in graphs. **Mathematica Bohemica**, page 22, 2006.
- [6] M. Kchikech, R. Khennoufa, O. Togni. Linear and cyclic radio k-labelings of trees. **Discussiones Mathematicae Graph Theory**, 27:105, 2007.
- [7] R. Čada, J. Ekstein, P. Holub, O. Togni. Radio labelings of distance graphs. **Discrete Applied Mathematics**, 161, 2876–2884, 2013.

On superperfection of edge intersection graphs of paths

Hervé Kerivin and Annegret Wagler

LIMOS, University Clermont Auvergne, France

EXTENDED ABSTRACT

Flexgrid Elastic Optical Networks constitute a new generation of optical networks in response to the sustained growth of data traffic volumes and demands in communication networks. In such networks, light is used as communication medium between sender and receiver nodes, and the frequency spectrum of an optical fiber is divided into narrow frequency slots. Any sequence of consecutive slots can form a channel that can be switched in the network to create a lightpath (i.e., an optical connection represented by a route and a channel). The *Routing and Spectrum Assignment (RSA) problem* consists of establishing the lightpaths for a set of end-to-end traffic demands, that is, finding a route and assigning an interval of consecutive frequency slots for each demand such that the intervals of lightpaths using a same edge in the network are disjoint, see e.g. [11]. I.e., we are given a network G and a set \mathcal{D} of traffic demands between pairs u, v of nodes in G specifying the number d_{uv} of required frequency slots to satisfy this demand. The routing consists of selecting a (u, v) -path P_{uv} in G , for each such traffic demand. The spectrum assignment can then be interpreted as an *interval coloring of the edge intersection graph $I(\mathcal{P})$* of the set \mathcal{P} of selected paths:

- Each path $P_{uv} \in \mathcal{P}$ becomes a node of $I(\mathcal{P})$ and two nodes are joined by an edge if the corresponding paths in G are in conflict as they share an edge (notice that we do not care whether they share nodes).
- Any interval coloring in this graph $I(\mathcal{P})$ weighted with the demands d_{uv} solves the spectrum assignment: we assign an interval of d_{uv} consecutive frequency slots to every node of $I(\mathcal{P})$ (and, thus, to every path $P_{uv} \in \mathcal{P}$) in such a way that the intervals of adjacent nodes are disjoint.

The *interval chromatic number* $\chi_I(I(\mathcal{P}), d)$ is the smallest spectrum width such that $I(\mathcal{P})$ weighted with the vector d of traffic demands d_{uv} for each path P_{uv} has a proper interval coloring. Given G and \mathcal{D} , the minimum spectrum width of any solution of the RSA problem, thus, equals $\chi_I(G, \mathcal{D}) = \min\{\chi_I(I(\mathcal{P}), d) : \mathcal{P} \text{ possible routing of demands } \mathcal{D} \text{ in } G\}$.

For each routing \mathcal{P} , the *weighted clique number* $\omega(I(\mathcal{P}), d)$ is a natural lower bound for $\chi_I(I(\mathcal{P}), d)$. Thus, $\omega(G, \mathcal{D}) = \min\{\omega(I(\mathcal{P}), d) : \mathcal{P} \text{ possible routing of demands } \mathcal{D} \text{ in } G\}$ is a lower bound for $\chi_I(G, \mathcal{D})$. However, it is not always possible to find a solution with $\omega(G, \mathcal{D})$ as spectrum width, as weighted clique number and interval chromatic number are not always equal. Graphs where both parameters coincide for all possible non-negative integral weights are called *superperfect*. A graph $G = (V, E)$ is *comparability* if and only if there exists a partial order \mathcal{O} on $V \times V$ such that $uv \in E$ if and only if u and v are comparable w.r.t. \mathcal{O} . Comparability graphs form a subclass of superperfect graphs [7], but there are also superperfect non-comparability graphs such as e.g. even antiholes [4].

A complete list of minimal non-comparability graphs is presented in [3], the question which minimal non-comparability graphs are superperfect has been addressed in [1]¹. The minimal non-comparability graphs which are not superperfect are thus minimal non-superperfect: the graphs \bar{A}_1 and \bar{A}_2 shown in Fig. 1 and all

- odd holes C_{2k+1} and odd antiholes \bar{C}_{2k+1} for $k \geq 2$,
- the graphs J_k and J'_k for $k \geq 2$ (see Fig. 2),
- the complements of D_k for $k \geq 2$ and of E_k, F_k for $k \geq 1$ (see Fig. 3).

We examine, for different underlying networks G , the question whether or not there is a solution of the RSA problem with $\omega(G, \mathcal{D})$ as spectrum width which depends on the occurrence of (minimal) non-superperfect graphs in the edge intersection graphs $I(\mathcal{P})$.

¹Note that \bar{A}_2 has been wrongly determined as superperfect in [1] which is, in fact, not the case as the weights indicated in Fig. 1 show.

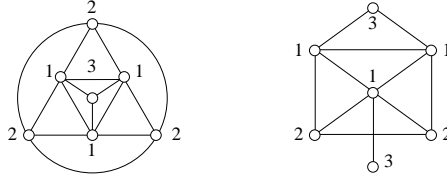

Figure 1: The graphs \bar{A}_1 and \bar{A}_2 .

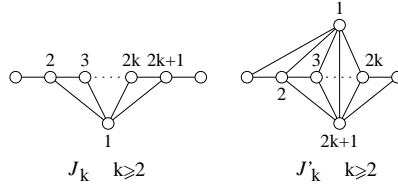

Figure 2: Minimal non-superperfect graphs: J_k, J'_k for $k \geq 2$.

For some networks G , the edge intersection graphs form well-studied graph classes: if G is a path (resp. tree, resp. cycle), then $I(\mathcal{P})$ is an interval graph (resp. EPT graph, resp. circular-arc graph). Modern optical networks do not fall in any of these classes, but are 2-connected, sparse planar graphs with small maximum degree.

We first study the special cases and then examine the general case showing that all minimal non-comparability non-superperfect graphs can occur in $I(\mathcal{P})$ (which implies that there is not always a solution of the RSA problem with $\omega(G, \mathcal{D})$ as spectrum width).

Finally, we give some new examples of minimal non-superperfect graphs and propose to extend the concept of χ -binding functions introduced in [6] for usual coloring to interval coloring in weighted graphs to describe how large the gap between weighted clique number and interval chromatic number can be in the worst case.

If the underlying network is a path P , then there is exactly one (u, v) -path P_{uv} in P for every traffic demand between a pair u, v of nodes. Hence, \mathcal{P} and $I(\mathcal{P})$ are uniquely determined for any set of demands, and the RSA problem reduces to the spectrum assignment part. The edge intersection graph $I(\mathcal{P})$ of the (unique) routing \mathcal{P} is an *interval graph* (i.e. the intersection graph of intervals in a line, here represented as subpaths of a path). Based on the characterization of minimal non-interval graphs from [9], we can show:

Theorem 1 *If \mathcal{P} is a set of paths in a path, then the interval graph $I(\mathcal{P})$ can contain the graphs J_k and J'_k for all $k \geq 2$ and \bar{E}_2 , but none of the other minimal non-comparability non-superperfect graphs.*

If the underlying network is a tree T , then there is also exactly one (u, v) -path P_{uv} in T for every traffic demand between a pair u, v of nodes and, thus, \mathcal{P} and $I(\mathcal{P})$ are uniquely determined. The edge intersection graph $I(\mathcal{P})$ of the (unique) routing \mathcal{P} is called an *EPT graph*. Based on results from [5], we can show:

Theorem 2 *If \mathcal{P} is a set of paths in a tree, then the EPT graph $I(\mathcal{P})$ can contain \bar{A}_1, \bar{A}_2 and*

- *odd holes C_{2k+1} for $k \geq 2$, but no odd antiholes \bar{C}_{2k+1} for $k \geq 3$,*
- *the graphs J_k and J'_k for all $k \geq 2$,*
- *$\bar{D}_2, \bar{D}_3, \bar{E}_1, \bar{E}_2, \bar{E}_3, \bar{F}_1, \bar{F}_2, \bar{F}_3$, but none of $\bar{D}_k, \bar{E}_k, \bar{F}_k$ for $k \geq 4$.*

If the underlying network is a cycle C , then there exist exactly two (u, v) -paths P_{uv} in C for every traffic demand between a pair u, v of nodes. Hence, the number of possible

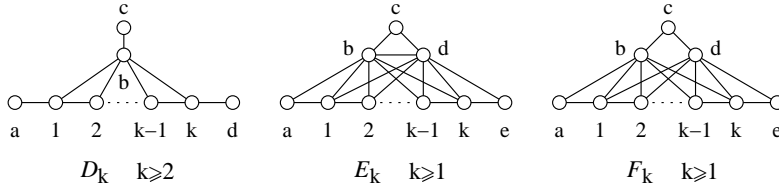

Figure 3: Minimal non-superperfect graphs: the complements of D_k, E_k, F_k .

routings \mathcal{P} (and their edge intersection graphs $I(\mathcal{P})$) is exponential in $|\mathcal{D}|$. Moreover, the edge intersection graphs of paths in a cycle are clearly *circular-arc graphs* (that are the intersection graphs of arcs in a cycle, here represented as paths in a hole C_n). Based on different results on circular-arc graphs, e.g. surveyed in [2], we can show:

Theorem 3 *If \mathcal{P} is a set of paths in a cycle, then the circular-arc graph $I(\mathcal{P})$ can contain \overline{A}_1 but not \overline{A}_2 ,*

- all odd holes C_{2k+1} and odd antiholes \overline{C}_{2k+1} for $k \geq 2$,
- the graphs J_k and J'_k for all $k \geq 2$,
- $\overline{D}_2, \overline{D}_3, \overline{D}_4$, but not the graphs \overline{D}_k for $k \geq 5$,
- \overline{E}_1 and \overline{E}_2 , but not the graphs \overline{E}_k for $k \geq 3$,
- \overline{F}_2 , but not \overline{F}_1 neither the graphs \overline{F}_k for $k \geq 3$.

Modern optical networks have clearly not a tree-like structure neither are just cycles due to survivability aspects concerning node or edge failures in the network G , see e.g. [8]. Instead, today's optical networks are 2-connected, sparse planar graphs with small maximum degree, see e.g. [10]. Based on the previous results, we can show:

Theorem 4 *All minimal non-comparability non-superperfect graphs can occur in edge intersection graphs $I(\mathcal{P})$ of sets \mathcal{P} of paths in optical networks G .*

In addition, there are further minimal non-superperfect graphs in edge intersection graphs of paths in networks. Fig. 4 shows two examples containing \overline{C}_6 (the smallest minimal non-comparability superperfect graph) together with weight vectors d causing a gap between weighted clique and interval chromatic number. Note that these two graphs are neither EPT graphs nor circular-arc graphs, but have a path representation in sparse planar graphs.

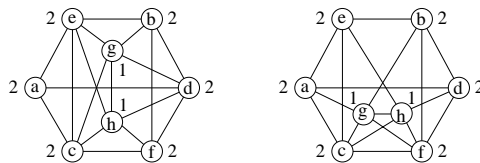

Figure 4: Minimal non-superperfect graphs $\overline{C}_{6,0}$ and $\overline{C}_{6,2}$ containing \overline{C}_6 .

From the examples presented in Fig. 4, we can construct an infinite family of new minimal non-superperfect graphs. Let \overline{C}_{2k} be an even antihole for some $k \geq 3$ and let $\overline{C}_{2k,j}$ be the graph obtained from \overline{C}_{2k} by adding two adjacent nodes x and y , where x is adjacent to all nodes of \overline{C}_{2k} but 1 and 2, and y is adjacent to all nodes of \overline{C}_{2k} but $2+j$ and $3+j$, for all even j with $0 \leq j < k$. Note that \overline{F}_1 can be considered to be $\overline{C}_{4,0}$; $\overline{C}_{6,0}$ and $\overline{C}_{6,2}$ are the graphs shown in Fig. 4.

Concluding remarks. From the fact that both, EPT graphs and circular-arc graphs, are not necessarily superperfect, we notice that also edge intersection graphs of paths in networks are not necessarily superperfect. If we restrict the networks to paths, then $I(\mathcal{P})$ is an interval graph, but still not necessarily superperfect. Hence, in all networks, it depends on the weights d induced by the traffic demands whether there is a gap between the weighted clique number $\omega(I(\mathcal{P}), d)$ and the interval chromatic number $\chi_I(I(\mathcal{P}), d)$. To determine the size of this gap, we propose to extend the concept of χ -binding functions introduced in [6] for usual coloring to interval coloring in weighted graphs, that is, to χ_I -binding functions f with

$$\chi_I(I(\mathcal{P}), d) \leq f(\omega(I(\mathcal{P}), d))$$

for edge intersection graphs $I(\mathcal{P})$ in a certain class of networks and all possible non-negative integral weights d .

Furthermore, in networks different from trees, the routing part of the RSA problem is crucial and raises the question whether it is possible to select the routes in \mathcal{P} in such a way that neither non-superperfect graphs nor unnecessarily large weighted cliques occur in $I(\mathcal{P})$.

Finally, giving a complete list of minimal non-superperfect graphs is an open problem, so that our future work comprises to find more minimal non-superperfect graphs and to examine the here addressed questions for them.

References

- [1] T. Andreae. On superperfect noncomparability graphs: In **J. of Graph Theory** 9:523–532, 1985.
- [2] G. Durán, L.N. Grippo and M.D. Safe. Structural results on circular-arc graphs and circle graphs: A survey and the main open problems. In **Discrete Applied Mathematics** 164:427–443, 2014.
- [3] T. Gallai. Transitiv orientierbare Graphen: In **Acta Math. Acad. Sci. Hungar.** 18:25–66, 1967.
- [4] M. Golumbic. *Algorithmic Graph Theory and Perfect Graphs*, 2nd Ed., North Holland, 2004.
- [5] M. Golumbic, R. Jamison. The edge intersection graphs of paths in a tree: In **J. Comb. Theory B** 38:8–22, 1985.
- [6] A. Gyárfás. Problems from the world surrounding perfect graphs: In **Zastos. Mat.** 19:413–431, 1987.
- [7] A. Hoffman. A generalization of max flow-min cut: In **Math. Programming** 6:352–359, 1974.
- [8] H. Kerivin and A.R. Mahjoub. Design of survivable networks: A survey. In **Networks** 46:1–21, 2005.
- [9] C. Lekkerkerker and D. Boland. Representation of finite graphs by a set of intervals on the real line: In **Fundamenta Mathematicae** 51:45–64, 1962.
- [10] Ruiz, M., M. Pioro, M. Zotkiewicz, M. Klinkowski, and L. Velasco, *Column generation algorithm for RSA problems in flexgrid optical networks*, *Photonic Network Communications* **26** (2013), 53–64.
- [11] S. Talebi et. al. Spectrum management techniques for elastic optical networks: A survey. In **Optical Switching and Networking** 13:34–48, 2014.

Fractional eternal domination

Devvrit Khatri¹, Aaron Krim-Yee², Nithish Kumar³, Gary MacGillivray⁴,
Ben Seamone⁵, Virg lot Virgile⁴, AnQi Xu⁶

¹ Department of Computer Science, University of Texas at Austin, USA

² Department of Electrical and Computer Engineering, McGill University, Montr al, Canada

³ Department of Computer Science, Purdue University, West Lafayette, IN, USA

⁴ Department of Mathematics and Statistics, University of Victoria, Canada

⁵ Department of Mathematics, Dawson College and D partement d'informatique et de
recherche op rationnelle, Universit  de Montr al, Canada

⁶ Facult  de m decine, Universit  de Montr al, Canada

EXTENDED ABSTRACT

Given a graph G , a set of vertices $X \subseteq V(G)$ is called a *dominating set* if every vertex not in X is adjacent to at least one vertex in X . The cardinality of a smallest dominating set is called the *domination number* of G , which is denoted $\gamma(G)$. A graph G is *S -fractionally dominated* if there exists a function $w : V(G) \rightarrow \mathbb{R}_{\geq 0}$ such that $\sum_{x \in N[v]} w(x) \geq 1$ and $\sum_{v \in V(G)} w(v) \leq S$. The *fractional domination number* of a graph G , denoted $\gamma_f(G)$, is the smallest value of S such that G can be S -fractionally dominated. It is not difficult to see that $\gamma(G)$ can be expressed as the solution to an integer program and $\gamma_f(G)$ is the solution to its linear relaxation. Fractional domination was introduced in [4] and has since been well-studied.

We study a variation on the *eternal domination* game. In this game, a dominating set of size k is first occupied by k “guards”. An infinite sequence of vertices is then revealed one at a time (each reveal is called an “attack”). After each attack, a guard adjacent to the attacked vertex must move from its current location to the attacked vertex. After each attack, the guards’ positions must still be a dominating set. The minimum number of guards required to defend any infinite sequence of attacks on $V(G)$ is called the *eternal domination number* of G , denoted $\gamma^\infty(G)$. In the original version of the game, first appearing in [1], only one guard may move after each attack. In a variation introduced in [3], any number of guards may move after each attack. The minimum number of guards required in this model, known as the *m -eternal domination number* of G , is denoted $\gamma_m^\infty(G)$.

In this talk, we present the *fractional eternal domination* model, which may be considered a fractional relaxation of m -eternal domination. One assigns non-negative real weights to $V(G)$ so that S -fractional domination can be maintained for some fixed value S subject to vertex attacks. For each vertex $v \in V(G)$, set $w_0(v) = w(v)$ so that G is fractionally dominated. At discrete time steps $k = 1, 2, 3, \dots$ an adversary attacks an arbitrary $v \in V(G)$. To respond to the k^{th} attack, one may move any non-negative amount of weight, say m , from u to v as long as $m \leq w_{k-1}(u)$ and u is adjacent to v . We may do this simultaneously along as many edges as necessary, but require that G is fractionally dominated by the resulting weighting w_k . We denote by $\gamma_f^\infty(G)$ the infimum over all S for which G can be eternally S -fractionally dominated, and call the parameter the *fractional eternal domination number* of G . This idea was first suggested in [2], in the more general context of the Spy Game.

In this talk, we present some (partial) progress on the following general questions.

1. How does $\gamma_f^\infty(G)$ relate to other domination parameters?

It is not difficult to see that each of the following inequalities must always hold:

$$\begin{aligned} \gamma_f(G) &\leq \gamma_f^\infty(G) \leq \gamma_m^\infty(G) \\ \gamma_f(G) &\leq \gamma(G) \leq \gamma_m^\infty(G) \end{aligned}$$

This may lead one to ask whether or not $\gamma_f^\infty(G)$ and $\gamma(G)$ are, in general, comparable. Our first results show that, in general, the two parameters are not related.

Theorem 1 For any integer N , there exist graphs G and H such that $\gamma_f^\infty(G) - \gamma(G) > N$ and $\gamma(H) - \gamma_f^\infty(H) > N$.

Considering the ratio of the two parameters, we can see that $\gamma_f^\infty(G)/\gamma(G)$ can be made arbitrarily small, but not arbitrarily large.

Theorem 2

1. For any $\varepsilon > 0$, there exists a graph G such that $\gamma_f^\infty(G)/\gamma(G) < \varepsilon$.
2. For any graph G , $\gamma_f^\infty(G)/\gamma(G) \leq 2$.

Furthermore, the bound in statement 2 is tight.

2. Can we determine exact values, or good bounds, for $\gamma_f^\infty(G)$?

Computing the exact values of $\gamma_f^\infty(G)$ for complete graphs, paths, cycles, complete graphs, and complete multipartite graphs is straightforward. As a consequence of the aforementioned results in [2], it is known that $\gamma_f^\infty(T) = \gamma_m^\infty(T)$ for any tree T . Beyond this, computing exact values of $\gamma_f^\infty(G)$ even for restricted graph classes appears to be non-trivial. Bounds for grids and tori can be found in [2]. We prove bounds for split graphs (the upper bound is best possible) and graphs with high connectivity:

Theorem 3 If G is a split graph, then $\gamma_f(G) \leq \gamma_f^\infty(G) \leq \gamma_f(G) + 1$.

Theorem 4 If G has connectivity κ , then $\gamma_f^\infty(G) \leq \frac{n+\kappa}{\kappa+1}$.

As a consequence of Theorem 4, we are able to deduce that $\gamma_f^\infty(G)$ does not differ significantly from $\gamma_f(G)$ in abelian Cayley graphs (and so, in particular, for hypercubes).

Theorem 5 If G is an abelian Cayley graph, then $\gamma_f^\infty(G) - \gamma_f(G) < 1$.

By applying a classification of cubic abelian Cayley graphs from [5], we are able to prove the following stronger result for this class:

Theorem 6 If G is an abelian cubic Cayley graph, then $\gamma_f^\infty(G) = \gamma(G)$ if and only if G is not isomorphic either to $C_{4k+2} \square K_2$ or to $\text{Cay}(\mathbb{Z}_{8k}, \{\pm 1, 4k\})$ for some integer $k \geq 1$. Furthermore, if G falls into either of these two exceptional families, then $\gamma_f^\infty(G) < \gamma(G)$.

Determining the exact values of $\gamma_f^\infty(G)$ for the two exceptional families stated in Theorem 6 remains largely an open problem; though we are able to determine the exact value in a few special cases, even the value of $\gamma_f^\infty(C_6 \square K_2)$ remains undecided.

3. What numerical values of $\gamma_f^\infty(G)$ are possible?

We give a construction of a family of graphs which shows the following:

Theorem 7 For any rational number $q \geq 2$, there exists an infinite family of graphs \mathcal{G}_q such that $\gamma_f^\infty(G) = q$ for every $G \in \mathcal{G}_q$.

A number of open problems related to the possible numerical values of $\gamma_f^\infty(G)$ will be presented as avenues for future research.

References

- [1] A. P. Burger, E. J. Cockayne, W. R. Gründlingh, C. M. Mynhardt, J. H. van Vuuren, and W. Winterbach. Infinite order domination in graphs. **J. Combin. Math. Combin. Comput.** 50:179–194, 2004.
- [2] N. Cohen, F. Mc Inerney, N. Nisse, and S. Pérennes. Study of a combinatorial game in graphs through Linear Programming. **Algorithmica** 1-33, 2018.
- [3] W. Goddard, S. M. Hedetniemi, and S. T. Hedetniemi. Eternal security in graphs. **J. Combin. Math. Combin. Comput.** 52:169–180, 2005.
- [4] D. L. Grinstead and P. J. Slater. Fractional domination and fractional packing in graphs. Proceedings of the Twentieth Southeastern Conference on Combinatorics, Graph Theory, and Computing (Boca Raton, FL, 1989). **Congr. Numer.** 71:153–172, 1990.
- [5] S. Wai-Chee. On 3-regular and 4-regular Cayley Graphs of Abelian Groups. Technical Report. Hong Kong Baptist University, Dept. of Mathematics, 1995.

The existence of a path-factor involving paths of order eleven

Keiko Kotani

Department of Mathematics, Tokyo University of Science, Japan

EXTENDED ABSTRACT

This talk is based on joint work with M. Murakami.

In this talk, all graphs are finite and simple. For a graph G and an integer $l \geq 1$, we let $c_l(G)$ denote the number of components of G having order l . For an integer $l \geq 2$, we let P_l denote the path of order l . A path-factor of a graph G is a spanning subgraph whose components are paths of order at least 2. By a $\{P_2, P_{2k+1}\}$ -factor of a graph G , we mean a spanning subgraph of G each of whose components is isomorphic to P_2 or P_{2k+1} . Since every path of order at least 2 can be partitioned into paths of orders 2 and 3, a graph has a path-factor if and only if it has a $\{P_2, P_3\}$ -factor.

In [1], a necessary and sufficient condition for the existence of a path-factor was obtained.

Theorem A *A graph G has a $\{P_2, P_3\}$ -factor if and only if $c_1(G - X) \leq 2|X|$ for all $X \subseteq V(G)$.*

In [2], it was shown that if a graph G satisfies $c_1(X) + 2c_3(G - X)/3 \leq 4|X|/3$ for all $X \subseteq V(G)$, then G has a $\{P_2, P_5\}$ -factor. The following conjecture was also made in [4].

Conjecture B *Let $k \geq 3$ be an integer, and let G be a graph such that $\sum_{0 \leq j \leq k-1} c_{2j+1}(G - X) \leq (4k+6)|X|/(8k+3)$ for all $X \subseteq V(G)$. Then G has a $\{P_2, P_{2k+1}\}$ -factor.*

For $k = 3, 4$, Conjecture B was settled in [3] as follows.

Theorem C *Let G be a graph such that $c_1(G - X) + c_3(G - X)/3 + c_5(G - X)/3 \leq 2|X|/3$ for all $X \subseteq V(G)$. Then G has a $\{P_2, P_7\}$ -factor.*

Theorem D *Let G be a graph such that $c_1(G - X) + c_3(G - X) + 2c_5(G - X)/3 + c_7(G - X)/3 \leq 2|X|/3$ for all $X \subseteq V(G)$. Then G has a $\{P_2, P_9\}$ -factor.*

For $k = 5$, we have recently proved the following theorem.

Theorem 1 *Let G be a graph such that $c_1(G - X) + c_3(G - X) + c_5(G - X) + 4c_7(G - X)/15 + 4c_9(G - X)/15 \leq 8|X|/15$ for all $X \subseteq V(G)$. Then G has a $\{P_2, P_{11}\}$ -factor.*

Note that Theorems D and 1 imply that the coefficient of $(4k+6)/(8k+3)$ of $|X|$ in Conjecture B is not best possible for $k = 4$ and 5. We have also proved the following proposition, which implies that the coefficient of $|X|$ in Theorem 1 is best possible in the sense that it cannot be replaced by any number greater than $8/15$.

Proposition 2 *There exist infinitely many graphs G having no $\{P_2, P_{11}\}$ -factor such that $\sum_{0 \leq j \leq 4} c_{2j+1}(G - X) \leq 8|X|/15 + 4/15$ for all $X \subseteq V(G)$.*

In this talk, I will describe about a sketch of the proof of Theorem 1 and show examples which satisfy the conditions of Proposition 2. I will also describe the sharpness of other coefficients.

References

- [1] J. Akiyama, D. Avis and H. Era, On a 1,2-factor of a graph. In **TRU Math.** 16 (1980), no. 2, 97–102.
- [2] D. Bauer, H. J. Broersma, and J. Veldman, Not every 2-tough graph is Hamiltonian. In **Discrete Appl. Math.** 99 (2000), no. 1-3, 317–321.
- [3] Y. Egawa and M. Furuya Path-factors involving paths of order seven and nine. In **Theory Appl. Graphs** 3 (2016), no. 1, Art. 5, 28 pp.
- [4] Y. Egawa and M. Furuya The existence of a path-factor without small odd paths. In **Electron. J. Combin.** 25 (2018), no. 1, Paper 1.40, 20 pp.

r -hued coloring of planar graphs with girth at least 8

Hoang La, Mickael Montassier, Alexandre Pinlou, and Petru Valicov

LIRMM, University of Montpellier, CNRS, France

EXTENDED ABSTRACT

In this paper, we consider simple undirected graphs without loops. A *proper k -coloring* of the vertices of a graph $G = (V, E)$ is an assignment of colors from 1 to k such that no two adjacent vertices have the same color. The *chromatic number* of G , denoted $\chi(G)$, is the smallest integer k so that G has a proper k -coloring. In 1969, Kramer and Kramer introduced the notion of *2-distance k -coloring* [23] which is a proper k -coloring such that no pair of vertices at distance 2 have the same color. The *2-distance chromatic number* of G , denoted $\chi^2(G)$, is the smallest integer k so that G has a 2-distance k -coloring. An example of 2-distance coloring is given in Figure 1a.

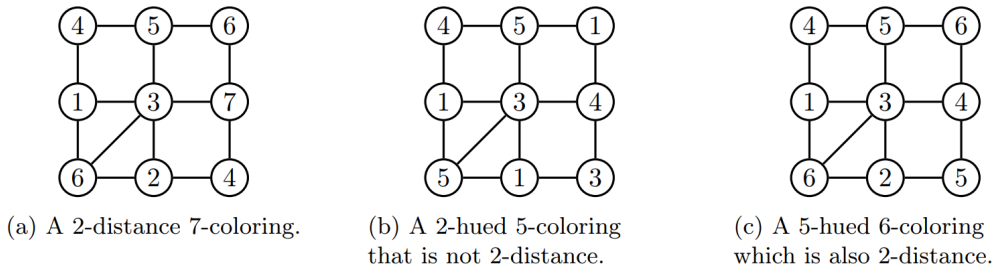

Figure 1: A graph G with $\chi^2(G) = 6$ and $\chi(G) = 3$

Note that for any graph G with maximum degree Δ , $\Delta + 1 \leq \chi^2(G) \leq \Delta^2 + 1$. The lower bound is trivial since, in a 2-distance coloring, every neighbor of a vertex v with degree Δ , and v itself must have a different color. As for the upper bound, a greedy algorithm shows that $\chi^2(G) \leq \Delta(G)^2 + 1$. Moreover, this bound is tight for some graphs, for example, Moore graphs of type $(\Delta, 2)$, which are graphs where all vertices have degree Δ , are at distance at most two from each other, and the total number of vertices is $\Delta^2 + 1$. The Moore graphs of type $(3, 2)$ and of type $(7, 2)$ are the Petersen graph and the Hoffman-Singleton graph respectively.

In this paper, we focus on *planar graphs* which are graphs that can be drawn in the plane without crossing the edges. One motivation to study this class of graphs is the following famous conjecture stating an upper bound which is linear in Δ :

Conjecture 1 (Wegner, 1977 [31]) *Let G be a planar graph with maximum degree Δ . Then,*

$$\chi^2(G) \leq \begin{cases} 7, & \text{if } \Delta \leq 3, \\ \Delta + 5, & \text{if } 4 \leq \Delta \leq 7, \\ \lfloor \frac{3\Delta}{2} \rfloor + 1, & \text{if } \Delta \geq 8. \end{cases}$$

Wegner showed that the upper bounds of the conjecture are tight. For instance when $\Delta \geq 8$ consider the Wegner graph obtained as follows : take a triangle xyz , multiply each edge $\frac{3}{2}\Delta$ times, subdivide them once, then add an edge between x and y . The case $\Delta \leq 3$ of Conjecture 1 was proved independently by Thomassen [29] and by Hartke *et al.* [17]. For $\Delta \geq 8$, Havet *et al.* [18] proved that the bound is $\frac{3}{2}\Delta(1 + o(1))$, where $o(1)$ is as $\Delta \rightarrow \infty$.

The coefficient before Δ becomes 1 when the *girth*, the length of a shortest cycle, of the graph increases. Extensive researches have been done in this case, and many results have taken the following form: *every planar graph G of girth $g \geq g_0$ and $\Delta(G) \geq \Delta_0$ satisfies $\chi^2(G) \leq \Delta + c(g_0, \Delta_0)$, where $c(g_0, \Delta_0)$ is a constant depending only on g_0 and Δ_0 .* Table 1 shows all known such results on the 2-distance chromatic number of planar graphs with fixed girth, up to our own knowledge.

$g_0 \setminus \chi^2(G)$	$\Delta + 1$	$\Delta + 2$	$\Delta + 3$	$\Delta + 4$	$\Delta + 5$	$\Delta + 6$	$\Delta + 7$	$\Delta + 8$
3	X			$\Delta = 3[29, 17]$				
4	X							
5	X	$\Delta \geq 10^7[1]$	$\Delta \geq 339[15]$	$\Delta \geq 312[14]$	$\Delta \geq 15[8]$	$\Delta \geq 12[7]$	$\Delta \neq 7, 8[14]$	all $\Delta[30]$
6	X	$\Delta \geq 17[4]$	$\Delta \geq 9[7]$		all $\Delta[10]$			
7	$\Delta \geq 16[19]$			$\Delta = 4[12]$				
8	$\Delta \geq 10[19]$ $\Delta \geq 9$ (Corollary 4)		$\Delta = 5[6]$					
9	$\Delta \geq 8[3]$	$\Delta = 5[6]$	$\Delta = 3[13]$					
10	$\Delta \geq 6[19]$							
11		$\Delta = 4[12]$						
12	$\Delta = 5[19]$	$\Delta = 3[5]$						
13								
14	$\Delta \geq 4[2]$							
...								
22	$\Delta = 3[19]$							

Table 1: The latest results with a coefficient 1 before Δ in the upper bound of χ^2 .

For example, the result from line "7" and column " $\Delta + 1$ " from Table 1 reads as follows : "every planar graph G of girth at least 7 and of Δ at least 16 satisfies $\chi^2(G) \leq \Delta + 1$ ". The crossed out cases in the first column correspond to the fact that, for $g_0 \leq 6$, there are planar graphs G with $\chi^2(G) = \Delta + 2$ for arbitrarily large $\Delta[16]$. The lack of results for $g \geq 4$ is due to the fact that the Wegner graph without xy has girth 4, and $\chi^2 = \lfloor \frac{3\Delta}{2} \rfloor - 1$ for all Δ .

The "2-distance" condition in 2-distance colorings requires that vertices at distance at most two have different colors. In other words, all neighbors of the same vertex must have different colors. Recently, this condition was generalized and the notion of r -hued coloring was introduced [26]. Let $r, k \geq 1$ be two integers. An r -hued k -coloring of the vertices of G is a proper k -coloring of the vertices, such that all vertices are r -hued. A vertex is r -hued if the number of colors in its neighborhood $N_G(v) = \{x| xv \in E\}$ is at least $\min\{d_G(v), r\}$. The r -hued chromatic number of G , denoted $\chi_r(G)$, is the smallest integer k so that G has an r -hued k -coloring. It is indeed a generalization of 2-distance colorings which correspond to the case $r \geq \Delta$, as all vertices in the same neighborhood will have different colors. More generally, its link to proper coloring and 2-distance coloring resides in the following equation:

$$\chi(G) = \chi_1(G) \leq \chi_2(G) \leq \dots \leq \chi_\Delta(G) = \chi_{\Delta+1}(G) = \dots = \chi^2(G) \quad (1)$$

Examples of r -hued colorings are given in Figure 1b and Figure 1c.

Similar to the 2-distance chromatic number, the r -hued chromatic number is linear in r when it comes to planar graphs. In 2014, Song *et al.* proposed a generalization of Conjecture 1:

Conjecture 2 (Song *et al.*, 2014 [27]) *Let G be a planar graph. Then,*

$$\chi_r(G) \leq \begin{cases} r + 3, & \text{if } 1 \leq r \leq 2, \\ r + 5, & \text{if } 3 \leq r \leq 7, \\ \lfloor \frac{3r}{2} \rfloor + 1, & \text{if } r \geq 8. \end{cases}$$

Note that Conjecture 2 implies Conjecture 1 except for the case $r = 3$. Moreover, the only extremal known examples reaching the upper bounds of Conjecture 2 are the same as for Conjecture 1. It is less clear what would be the expected upper bound when $r < \Delta$. In 2018, Song and Lai [28] proved that, if $r \geq 8$, then every planar graph G verifies $\chi_r(G) \leq 2r + 16$. Similar to 2-distance coloring, the coefficient before r in this upper bound becomes 1 for graphs with a higher girth. Table 2 shows all known results of the following form: *let r and r_0 be integers such that $r \geq r_0$, all planar graph G of girth $g(G) \geq g_0$ satisfies $\chi_r(G) \leq r + c(g_0, r_0)$, where $c(g_0, r_0)$ is a constant depending only on g_0 and r_0 .* The result from the "9" line and " $r + 1$ " column reads "for $r \geq 8$, all planar graph G of girth at least 9 satisfies $\chi_r(G) \leq r + 1$ ".

Since $r + 1$ is a trivial lower bound for χ_r , we study the class of planar graphs verifying $\chi_r = r + 1$ and show the following:

$g_0 \setminus \chi_r(G)$	$r+1$	$r+2$	$r+3$	$r+4$	$r+5$	$r+6$	$r+7$...	$r+10$
3		$r = 2[20]^1$	$r = 2[20]$	$r = 2[22]$			$r = 3[25]$		
4									
5					$r \geq 15[8]$				all $r[8]$
6					$r \geq 3[24]$				
7		$r = 2[22]$		$r = 3[21]$					
8	$r \geq 9$ (Theorem 3)								
9	$r \geq 8[9]$		$r = 3[21]$						
10	$r \geq 6[9]$								
11									
12	$r \geq 5[9]$								
13									
14		$r = 3[11]$							

Table 2: The latest results with a coefficient 1 before r in the upper bound of χ_r .

Theorem 3 *If G is a planar graph with $g(G) \geq 8$, then $\chi_r(G) = r + 1$ for $r \geq 9$.*

Our proof uses the discharging method and exploits planarity arguments.

For $r \geq \Delta$, Theorem 3 gives an improvement of a result on 2-distance coloring published in [19] (see Table 1):

Corollary 4 *If G is a planar graph with $g(G) \geq 8$ and $\Delta(G) \geq 9$, then $\chi^2(G) = \Delta(G) + 1$.*

References

- [1] M. Bonamy, D. Cranston, L. Postle. Planar graphs of girth at least five are square $(\Delta + 2)$ -choosable. In **J. Comb. Theory, Series B**. 134:218–238, 2019.
- [2] M. Bonamy, B. Lévêque, A. Pinlou. 2-distance coloring of sparse graphs. In **Discrete Math.** 38:155–160, 2011.
- [3] M. Bonamy, B. Lévêque, A. Pinlou. 2-distance coloring of sparse graphs. In **J. Graph Theory**. 77(3), 2014.
- [4] M. Bonamy, B. Lévêque, A. Pinlou. Graphs with maximum degree $\Delta \geq 17$ and maximum average degree less than 3 are list 2-distance $(\Delta + 2)$ -colorable. In **Discrete Math.** 317:19–32, 2014.
- [5] O.V. Borodin, A.O. Ivanova. List 2-facial 5-colorability of plane graphs with girth at least 12. In **Discrete math.** 312:306–314, 2012.
- [6] Y. Bu, X. Lv, X. Yan. The list 2-distance coloring of a graph with $\Delta(G) = 5$. In **Discrete Math., Algo. and Appl.** 7(2), 2015.
- [7] Y. Bu, C. Shang. List 2-distance coloring of planar graphs without short cycles. In **Discrete Math., Algo. and Appl.** 8(1), 2016.
- [8] Y. Bu, J. Zhu. Channel Assignment with r -Dynamic Coloring. 12th International Conference, AAIM 2018, Dallas, TX, USA, December 3-4, 2018, Proceedings. 36–48, 2018.
- [9] Y. Bu, J. Zhu. List r -dynamic coloring of graphs with small maximum average degree. In **Discrete Appl. Math.** 258:254–263, 2019.
- [10] Y. Bu, X. Zhu. An optimal square coloring of planar graphs. In **J. Comb. Optim.** 24:580, 2012.
- [11] J. Cheng, H. -J. Lai, K. J. Lorenzen, R. Luo, J. C. Thompson, C. -Q. Zhang. r -hued coloring of sparse graphs. In **Discrete Appl. Math.** 237:75–81, 2018.

- [12] D. Cranston, R. Erman, R. Skrekovski. Choosability of the square of a planar graph with maximum degree four. In **Australian J. Comb.**. 59(1):86–97, 2014.
- [13] D. Cranston, S. Kim. List-coloring the square of a subcubic graph. In **J. Graph Theory**. 1:65–87, 2008.
- [14] W. Dong, W. Lin. On 2-distance coloring of plane graphs with girth 5. In **Discrete Appl. Math.**. 217:495–505, 2017.
- [15] W. Dong, B. Xu. 2-distance coloring of planar graphs with girth 5. In **J. Comb. Optim.**. 34:1302, 2017.
- [16] Z. Dvořák, D. Král, P. Nejedlý, R. Škrekovski. Coloring squares of planar graphs with girth six. In **European J. Comb.**. 29(4):838–849, 2008.
- [17] S. G. Hartke, S. Jahanbekam, B. Thomas. The chromatic number of the square of subcubic planar graphs. arXiv 1604.06404, 2018.
- [18] F. Havet, J. van den Heuvel, C. McDiarmid, B. Reed. List colouring squares of planar graphs. arXiv 0807.3233, 2017.
- [19] A. O. Ivanova. List 2-distance $(\Delta + 1)$ -coloring of planar graphs with girth at least 7. In **J. Appl. Ind. Math.**. 5(2):221–230, 2011.
- [20] S. -J. Kim, S. J. Lee, W. -J. Park. Dynamic coloring and list dynamic coloring of planar graphs. In **Discrete Appl. Math.**. 161:2207–2212, 2013.
- [21] S. -J. Kim, B. Park. List 3-dynamic coloring of graphs with small maximum average degree. In **Discrete Math.**. 341:1406–1418, 2018.
- [22] S. -J. Kim, W. -J. Park. List dynamic coloring of sparse graphs. In **Comb. Optim. and Appl.**. 6831:156–162, 2011.
- [23] F. Kramer, H. Kramer. Un problème de coloration des sommets d’un graphe. In **Comptes Rendus Mathématique, Académie des Sciences, Paris**. 268:46–48, 1969.
- [24] H. -J. Lai, H. Song, J. -L. Wu. On r -hued coloring of planar graphs with girth at least 6. In **Discrete Appl. Math.**. 198:251–263, 2016.
- [25] S. Loeb, T. Mahoney, B. Reiniger, J. Wise. Dynamic coloring parameters for graphs with given genus. In **Discrete Appl. Math.**. 235:129–141, 2018.
- [26] B. Montgomery. Ph.D. dissertation. West Virginia University, 2001.
- [27] Y. Chen, S. -H. Fan, H. -J. Lai, H. Song, L. Sun. On r -hued coloring of K_4 -minor free graphs. In **Discrete Math.**. 315-316:47–52, 2014.
- [28] H. -J. Lai, H. Song. Upper bound of r -hued colorings of planar graphs. In **Discrete Appl. Math.**. 243:262–369, 2018.
- [29] C. Thomassen. The square of a planar cubic graph is 7-colorable. In **J. Comb. Theory, Series B**. 128:192–218, 2018.
- [30] W. Dong, W. Lin. An improved bound on 2-distance coloring plane graphs with girth 5. In **J. Comb. Optim.**. 32(2):645–655, 2016.
- [31] G. Wegner. Graphs with given diameter and a coloring problem. Technical report, University of Dortmund, 1977.

Switching (m, n) -edge-coloured mixed graphs

Etienne Leclerc, and Gary MacGillivray

Mathematics and Statistics, University of Victoria
Victoria, BC, Canada

EXTENDED ABSTRACT

1 Overview

In what follows, we define a switching operation for (m, n) -edge-coloured mixed graphs in such a way that it generalizes the pushing operation for oriented graphs (e.g. see [4, 6]), and the switching operation for m -edge-coloured graphs (e.g. see [1, 7, 9]). The first step is to define (m, n) -edge-coloured mixed graphs and indicate how they generalize oriented graphs and edge-coloured graphs. That is done in the next section. In Section 3 we define the general switching operation with respect to a finite group, the concept of switch equivalence, and the concept of a switchable homomorphism. We state results which show that the main results of the theory previously developed for pushing and switching hold in this more general context. Subsequently, we focus on the situation where the group of possible switches is Abelian, and indicate that other results from the theories of pushing and switching hold. In particular, for each (m, n) -edge coloured graph H there is a special (m, n) -edge-coloured graph $P(H)$ such that G has a switchable homomorphism to H if and only if there is a homomorphism of G to $P(H)$. This theorem extends and contains results from [1, 6, 7, 9]. In the last section we define the switchable core of a (m, n) -edge-coloured mixed graph and state an extension of a result of Brewster and Graves [1] for switching m -edge-coloured graphs with respect to a cyclic group to switching (m, n) -edge-coloured mixed graphs with respect to an Abelian group.

2 (m, n) -edge-coloured mixed graphs

A *mixed graph* is an ordered triple $G = (V(G), E(G), A(G))$, where $V(G)$ is a set of objects called *vertices*, $E(G)$ is a multi-set of unordered pairs of not necessarily distinct vertices called *edges*, and $A(G)$ is a multi-set of ordered pairs of not necessarily distinct vertices called *arcs*. The mixed graph G is called *simple* if its underlying undirected graph is a simple graph.

A mixed graph G is *(m, n) -edge-coloured* if each edge is assigned one of the m colours $1, 2, \dots, m$ and each arc is assigned one of the n colours $1, 2, \dots, n$. For $1 \leq i \leq m$, let $E_i(G)$ be the *multi-set of edges of colour i* , and for $1 \leq j \leq n$, let $A_j(G)$ be the *multi-set of arcs of colour j* .

When the context is clear we write V, E and A instead of $V(G), E(G)$ and $A(G)$, respectively, and similarly for other subsets or parameters related to a graph.

Let G and H be (m, n) -edge-coloured mixed graphs. A (*coloured*) *homomorphism* of G to H is a function $f : V(G) \rightarrow V(H)$ such that if the edge $ab \in E_i(G)$, then $f(a)f(b) \in E_i(H)$, and if the arc $ab \in A_j(G)$ then $f(a)f(b) \in A_j(H)$. A homomorphism $G \rightarrow H$ preserves edges, arcs, and colours. If there is a homomorphism of G to H , we may write $G \rightarrow H$.

Observe that $(1, 0)$ -edge coloured mixed graphs are undirected graphs, $(m, 0)$ -edge coloured mixed graphs are m -edge-coloured graphs, and $(0, 1)$ -edge-coloured mixed graphs are directed graphs. The definition of homomorphism given above restricts to the usual definition in each of these cases. The (m, n) -edge-coloured mixed graphs and homomorphisms between them were first introduced in [8] as a means of unifying the seemingly parallel theories of homomorphisms of oriented graphs and homomorphisms of 2-edge-coloured graphs: quite often statements that hold for oriented graphs, for example, also hold for 2-edge-coloured graphs with virtually the same proof (e.g. see [5]). In such cases it is reasonable to look for a general

theorem about (m, n) -edge-coloured mixed graphs that contains these statements as special cases (for example, see [8]).

3 Switching and switch equivalence

We now define the switching operation on a (m, n) -edge-coloured mixed graph $G = (V, E, A)$. Let $\phi \in S_m$, $\psi \in S_n$, and $\pi = (p_1, p_2, \dots, p_n) \in (\mathbb{Z}_2)^n$. For the ordered triple $\gamma = (\phi, \psi, \pi)$, define γ -switching at $v \in V$ to be the operation that transforms G into the (m, n) -edge-coloured mixed graph $G^{v, \gamma}$ by switching colours of the edges incident with v according to ϕ , the colours of the arcs incident with v according to ψ , and reversing the orientation of arcs of colour j incident with v if and only if $p_j = 1$. If E or A contains a loop vv , then the permutation ϕ or ψ is applied twice because there are two incidences with v . Thus, edges of colour i joining distinct vertices in G have colour $\phi(i)$ in $G^{v, \gamma}$, arcs of colour j joining distinct vertices in G have colour $\psi(j)$ in $G^{v, \gamma}$ and their orientation is reversed if and only if $p_j = 1$. Edge loops in G of colour i have colour $\phi(\phi(i))$ in $G^{v, \gamma}$, and arc loops in G of colour i have colour $\psi(\psi(i))$ in $G^{v, \gamma}$.

It follows from the definition of the wreath product $S_n \wr S_2$ (also known as the hyperoctahedral group) that the collection of all possible γ -switches is naturally isomorphic to $S_m \otimes (S_n \wr S_2)$. As an aside, it is known that the hyperoctahedral group is the automorphism group of the n -dimensional hypercube [3].

Let Γ be a fixed subgroup of $S_m \otimes (S_n \wr S_2)$. Then, the relation \sim_Γ on the set of all (m, n) -edge-coloured mixed graphs defined by $G \sim_\Gamma H$ if and only if there is a finite sequence of switches at vertices of G that transforms G into H is an equivalence relation. More formally, $G \sim_\Gamma H$ if and only if there is a finite sequence of (m, n) -edge-coloured mixed graphs G_0, G_1, \dots, G_k where $G_0 = G$, $G_k = H$, and for $0 \leq i \leq k-1$, $G_{i+1} = (G_i)^{v_i, \gamma_i}$ for some $v_i \in V$ and $\gamma_i \in \Gamma$. When $G \sim_\Gamma H$ we say that G and H are Γ -switch equivalent. The equivalence class of the (m, n) -edge coloured mixed graph G is denoted by $[G]_\Gamma$.

Let G and H be (m, n) -edge-coloured mixed graphs. We say that there is a Γ -switchable homomorphism of G to H if there is a homomorphism from some element $G' \in [G]_\Gamma$ to H . If some such homomorphism exists, we say that G is Γ -switchably homomorphic to H , and write $G \xrightarrow[\Gamma]{} H$.

Our definition for γ -switching restricts to the definitions given in [1, 6, 7, 9] for switching or pushing in the case of $(m, 0)$ or $(0, 1)$ graphs. In the former case, Γ consists of elements of the form (ϕ, e, e) , where e is the identity element. In the latter case, Γ consists of the two elements $(e, e, 0)$ and $(e, e, 1)$. Our definition of a Γ -switchable homomorphism thus naturally restricts to the previous definitions of switching and pushing.

The following statements can be proved in the same way as the corresponding results for oriented graphs with the pushing operation, and m -edge-coloured graphs with a switching operation.

Theorem 1 *Let F, G and H be (m, n) -edge-coloured mixed graphs.*

1. *If $G \in [H]_\Gamma$, then $G \xrightarrow[\Gamma]{} H$.*
2. *If $G \rightarrow H$, then $G \xrightarrow[\Gamma]{} H$.*
3. *If F is a subgraph of G and $G \xrightarrow[\Gamma]{} H$, then $F \xrightarrow[\Gamma]{} H$.*
4. *If $H' \in [H]_\Gamma$ and $G \rightarrow H$, then there exists $G' \in [G]_\Gamma$ such that $G' \rightarrow H'$.*
5. *If $G \xrightarrow[\Gamma]{} H$, then $G' \xrightarrow[\Gamma]{} H'$ for all $G' \in [G]_\Gamma$ and all $H' \in [H]_\Gamma$.*

4 Abelian groups and the switching graph

When Γ is Abelian the order in which elements of Γ are applied at various vertices does not matter. For this reason, to obtain any element of $[G]_\Gamma$, one can simply switch at every vertex $v \in G$ with some element $\gamma_v \in \Gamma$ (possibly the identity). It follows that if G can be transformed into H , then it can be done with a sequence of at most $|V(G)|$ switches. Thus the question of deciding whether G and H are Γ -switch equivalent is a finite question. By contrast, when Γ is non-Abelian it is not clear how many switches are required to transform G into H , if it is possible to do so.

Let Γ be an Abelian subgroup of $S_m \otimes (S_2 \wr S_n)$, and G be a (m, n) -edge-coloured mixed graph. The Γ -switching graph of G is the (m, n) -edge-coloured mixed graph $P_\Gamma(G)$ with vertex set $V(P_\Gamma(G)) = V(G) \times \Gamma$, and edges and arcs defined as follows:

1. If $xy \in E_i(G)$ and $\gamma_1 = (\phi_1, \psi_1, \pi_1)$ and $\gamma_2 = (\phi_2, \psi_2, \pi_2)$ are in Γ , then $(x, \gamma_1)(y, \gamma_2) \in E_r(P_\Gamma(G))$, where $r = \phi_1(i)\phi_2(i)$.
2. If $xy \in A_j(G)$ and $\gamma_1 = (\phi_1, \psi_1, \pi_1)$ and $\gamma_2 = (\phi_2, \psi_2, \pi_2)$ are in Γ , where $\pi_1 = (p_{1,1}, p_{1,2}, \dots, p_{1,n})$ and $\pi_2 = (p_{2,1}, p_{2,2}, \dots, p_{2,n})$, then
 - (a) if $p_{1,j} = p_{2,j}$, then $(x, \gamma_1)(y, \gamma_2) \in E_s(P_\Gamma(G))$, where $s = \psi_1(j)\psi_2(j)$, and
 - (b) if $p_{1,j} \neq p_{2,j}$, then $(y, \gamma_2)(x, \gamma_1) \in E_s(P_\Gamma(G))$, where $s = \psi_1(j)\psi_2(j)$.

The next theorem shows that, as in the cases of oriented graphs and the pushing operation, or m -edge coloured graphs and an Abelian switching operation, the Γ -switching graph gives a representation of $[G]_\Gamma$.

Define a *transversal subgraph* of $P_\Gamma(G)$ to be a subgraph of $P_\Gamma(G)$ induced by a transversal of the collection of $|V(G)|$ sets $\{(x, \gamma) : \gamma \in \Gamma, x \in V(G)\}$.

Theorem 2 *Let G be a (m, n) -edge-coloured mixed graph. Then $G' \in [G]_\Gamma$ if and only if G' is a transversal subgraph of $P_\Gamma(G)$.*

The Γ -switching graph, $P_\Gamma(G)$, transforms questions about Γ -switchable homomorphisms into questions about (ordinary) homomorphisms.

A Γ -switchable isomorphism between G and H is an isomorphism $G' \cong H$, where $G' \in [G]_\Gamma$. If some such isomorphism exists we say G is Γ -switchably isomorphic to H , and $G \cong_\Gamma H$. Equivalently, G is Γ -switchably isomorphic to H if and only if $G \in [H]_\Gamma$.

Theorem 3 *Let G and H be (m, n) -edge-coloured mixed graphs. Then*

1. $G \cong_\Gamma H$ if and only if $P_\Gamma(G) \cong P(H)$,
2. $G \xrightarrow[\Gamma]{} H$ if and only if $P_\Gamma(G) \rightarrow P(H)$, and
3. $G \xrightarrow[\Gamma]{} H$ if and only if $G \rightarrow P(H)$.

5 Switchable cores

A (m, n) -edge coloured mixed graph is a Γ -switchable core if it admits no Γ -switchable homomorphism to a proper subgraph. As in the previous section, for Abelian groups Γ we transform the problem of whether a graph is a Γ -switchable core into a problem that does not involve switching. The (m, n) -edge-coloured mixed graph $P_\Gamma(G)$ defined in the previous section is not in itself sufficient to accomplish this; however, a particular of $P_\Gamma(G)$ subgraph suffices for this purpose. The development below follows results implicit in [1] for m -edge-coloured graphs and switching with respect to cyclic groups.

For each vertex $x \in G$, define an equivalence relation \approx_x on Γ by $\gamma_1 = (\phi_1, \psi_1, \pi_1) \approx_x \gamma_2 = (\phi_2, \psi_2, \pi_2)$ if and only if

1. $\phi_1(f) = \phi_2(f)$ for every edge f incident with x ,
2. $\psi_1(a) = \psi_2(a)$ for every arc a incident with x , and
3. $\pi_1 = \pi_2$.

Let G be an (m, n) -edge-coloured mixed graph. The (m, n) -edge-coloured mixed graph $S_\Gamma(G)$ is obtained from $P_\Gamma(G)$ by identifying vertices (x, γ_1) and (x, γ_2) whenever $\gamma_1 \approx_x \gamma_2$ (note: necessarily the same x). Then $S_\Gamma(G)$ is a transversal subgraph of $P_\Gamma(G)$. Further, the mapping just defined is a homomorphism. Recall that H is a *retract* of G if it is an induced subgraph of G and there is a homomorphism $G \rightarrow H$ that fixes H .

Theorem 4 *Let G be a (m, n) -edge-coloured mixed graph, and Γ be an Abelian group. Then $S_\Gamma(G)$ is a retract of G . Further, all of the previous results hold with $S_\Gamma(G)$ in place of $P_\Gamma(G)$.*

In the following we generalize a result of Brewster and Graves [1] for m -edge-coloured graphs and switching with respect to cyclic groups to (m, n) -edge-coloured mixed graphs and switching with respect to Abelian groups.

Theorem 5 *Let G be a (m, n) -edge-coloured mixed graph, and Γ be an Abelian group. Then G is a Γ -switchable core if and only if $S_\Gamma(G)$ is a core.*

Hell and Nešetřil [2] proved that it is NP-complete to decide that a given graph is not a core. The following corollary arises from applying their result to (m, n) -edge-coloured graphs with only edges of one colour.

Corollary 6 *The problem of deciding whether a given (m, n) -edge-coloured graph is not a core is NP-complete.*

If Γ is an Abelian group, then there is a Γ -switchable homomorphism $P(G) \xrightarrow{\Gamma} G$. Thus, if G is a (m, n) -edge-coloured graph with only edges of one colour, then the Γ -switchable core of $P(G)$ is the core of G . Hence G is a Γ -switchable core if and only if G is a core.

Corollary 7 *Let Γ be an Abelian group. The problem of deciding whether a given (m, n) -edge-coloured graph is not a Γ -switchable core is NP-complete.*

References

- [1] T. Brewster, T. Graves, *Edge-switching homomorphisms of edge-coloured graphs*, Discrete Mathematics **309** (2006), p. 5540-5546
- [2] P. Hell, J. Nešetřil, *The core of a graph*, Discrete Math **109** (1992), p. 117-126
- [3] F. Harary, *The automorphism group of a hypercube*, UJCS **6** (2000), 136 – 138.
- [4] W.F. Klostermeyer, *pushing vertices and orienting edges*, Ars Combinatoria **51** (1999), 65 – 75.
- [5] A. Kostochka, E. Sopena, and Z. Zhu, *Acyclic and oriented chromatic numbers of graphs*, J. Graph Theory **24** (1997), 331–340/
- [6] W.F. Klostermeyer, G. MacGillivray, *Homomorphisms of equivalence classes of oriented graphs*, Discrete Mathematics **274** (2004), p. 161-172.
- [7] G. MacGillivray, B. Tremblay, J.M. Warren, *Colourings of m -edge-coloured graphs and switching*, Manuscript (2018).
- [8] J. Nešetřil, A. Raspaud, *Colored homomorphisms of colored mixed graphs* Journal of Combinatorial Theory, Series B **80** (2000), p. 147-155.
- [9] S. Sen, *A contribution to the theory of graph homomorphisms and colourings*, PhD Thesis, Bordeaux University, 2014.

Edge Degeneracy: Algorithmic and Structural Results¹

*Stratis Limnios*¹, *Christophe Paul*², *Joanny Perret*³, and *Dimitrios M. Thilikos*²

¹ Data Science and Mining (DaSciM) team, Laboratoire d'Informatique (LIX) École Polytechnique, Palaiseau, France.

² ALGCo project team, CNRS, LIRMM, Université de Montpellier, Montpellier, France.

³ GIPSA-lab, Université de Grenoble, Grenoble, France.

EXTENDED ABSTRACT

Abstract

We consider a cops and robber game where the cops are blocking edges of a graph, while the robber occupies its vertices. At each round of the game, the cops block some set of edges and right after the robber is obliged to move to another vertex traversing at most s unblocked edges (s can be seen as the speed of the robber). Both parts have complete knowledge of the opponent's moves and cops win when they occupy all edges incident to the robbers position. We introduce the capture cost on G against a robber of speed s . This defines a hierarchy of invariants, namely $\delta_e^1, \delta_e^2, \dots, \delta_e^\infty$, where δ_e^1 is the classic degeneracy invariant, while when δ_e^∞ is an edge-analogue of the admissibility invariant, namely the *edge-admissibility* of a graph. We prove that the problem asking whether $\delta_e^s(G) \leq k$, is polynomially solvable when $s \in \{1, 2, 3, \infty\}$ while, otherwise, it is NP-complete. Our main result is a structural theorem for graphs of bounded edge-admissibility. We prove that every graph of edge-admissibility at most k can be constructed using $(\leq k)$ -edge-sums, starting from graphs whose all vertices, except possibly from one, have degree at most k . Our structural result is approximately tight in the sense that graphs generated by this construction have always edge-admissibility at most $2k - 1$. Our proofs are based on a precise structural characterization of the graphs that do not contain θ_r as an immersion, where θ_r is the graph on two vertices and r parallel edges.

Keywords: Graph Immersions, Graph Degeneracy, Structural Graph Theory, Graph Admissibility, Graph Searching Games

1 Introduction

All graphs in this paper are undirected, finite, loopless, and may have parallel edges. We denote by $V(G)$ the set of vertices of a graph G while we use $E(G)$ for the multi-set of its edges.

An (k, s) -hide out in a graph G is a subset S of its vertices such that for each vertex $v \in S$ there are at least k paths from v to $S \setminus \{v\}$ that have no common vertices different than v . The s -degeneracy of a graph G has been introduced in [10] as the minimum k for which G contains a (k, s) -hide out. s -degeneracy, denoted also by δ^s , defines a hierarchy of parameters that when $s = 1$ gives the classic parameter of graph degeneracy [7, 1, 6] and, when $s = \infty$, gives the parameter of ∞ -admissibility that has been studied in [3, 5, 9, 2, 8, 11, 4]. In this paper we introduce the edge analogue of this graph parameter hierarchy, namely the s -edge-degeneracy hierarchy.

In Section 2 we introduce a graph searching game for this parameter and we provide alternative definitions whose equivalence is certified by a min-max theorem. Also we identify the computational complexity of s -edge-degeneracy for different values of s . In Section 3 we provide a structural characterization for the case where $s = \infty$. This characterization can be seen as the edge-counterpart of the corresponding structural characterization of ∞ -admissibility in [3].

¹The first, second, and third author is supported by project ESIGMA (ANR-17-CE23-0010). The second, and third author is supported by project DEMOGRAPH (ANR-16-CE40-0028). The last author is supported by the Research Council of Norway and the French Ministry of Europe and Foreign Affairs, via the Franco-Norwegian project PHC AURORA 2019.

2 s -edge-degeneracy

2.1 A search game.

We define a graph searching game, where the opponents are a group of cops and a robber. In this game, the cops are blocking edges of the graph, while the robber resides on the vertices. The first move of the game is done by the robber, who chooses a vertex to occupy. Then, the game is played in rounds. In each round, first the cops block a set of edges and next the robber moves to another vertex via paths consisting of at most s unblocked edges. The robber is captured if, after the move of the cops, all the edges incident to his/her current location are blocked and therefore cannot move anymore. Both cops and robbers have full knowledge of their opponent's current position and they take it into consideration before they make their next move. We next give the formal definition of the game.

The game is parameterized by the speed $s \in \mathbb{N}_{\geq 1}^+$ of the robber. A *search strategy* on G for the cops is a function $f : V(G) \rightarrow 2^{E(G)}$ that, given the current position $x \in V(G)$ of the robber in the end of a round, outputs the set $f(x)$ of the edges that should be blocked in the beginning of the next round. The *cost* of a cop strategy f is defined as $\mathbf{cost}(f) = \max\{|f(v)| \mid v \in V(G)\}$, i.e., the maximum number of edges that may be blocked by the cops according to f .

An *escape strategy* on G for the robber is a pair $R = (v_{\text{start}}, g)$ where v_{start} is the vertex of robber's first move and $g : 2^{E(G)} \times V(G) \rightarrow V(G)$ is a function that, given the set F of blocked edges in the beginning of a round and the current position x of the robber, outputs the vertex $u = g(F, x)$ where the robber should move. Here the natural restriction for g is that there is a path of at most s edges from x to u in $G \setminus F$. Clearly, if F is the set of edges that are incident to x , then $g(F, x)$ should be equal to x and this expresses the situation where the robber is captured.

Let f and $R = (v_{\text{start}}, g)$ be strategies for the cop and the robber respectively. The *game scenario* generated by the pair (f, R) is the infinite sequence $v_0, F_1, v_1, F_2, v_2, \dots$, where $v_0 = v_{\text{start}}$ and for every $i \in \mathbb{N}_{\geq 1}$, $F_i = f(v_{i-1})$ and $v_i = g(F_i, v_{i-1})$. If $v_i = v_{i-1}$ for some $i \in \mathbb{N}_{\geq 1}$, then (f, R) is a *cop-winning* pair, otherwise it is a *robber-winning* pair.

The *capture cost against a robber of speed s* in a graph G , denoted by $\mathbf{cc}_s(G)$ is the minimum k for which there is a cop strategy f , of cost at most k , such that for every robber strategy R , (f, R) is a cop-winning pair.

2.2 A min-max theorem for s -edge-degeneracy

Edge-degeneracy. Let G be a graph, $x \in V(G)$, $S \subseteq V(G) \setminus \{x\}$, and $s \in \mathbb{N}_{\geq 1}^+$. We say that a set $A \subseteq E(G)$ is an (s, x, S) -*edge-separator* if every path of G from x to some vertex in S , of length at most s , contains some edge from A . We define $\mathbf{supp}_G(s, x, S)$ to be the minimum size of a (s, x, S) -edge-separator in G .

Let G be a graph and let $L = \langle v_1, \dots, v_r \rangle$ be a layout (i.e. linear ordering) of its vertices. Given an $i \in [r]$, we write $L_{\leq i} = \langle v_1, \dots, v_i \rangle$. Given a $s \in \mathbb{N}_{\geq 1}^+$, we define the s -*edge-support* of a vertex v_i in L as $\mathbf{supp}_G(s, v_i, L_{\leq i-1})$. The s -*edge-degeneracy* of the layout L of G , is the maximum s -edge-support of a vertex in L . The s -*edge-degeneracy* of G , denoted by $\delta_s^e(G)$ is the minimum s -edge-degeneracy over all layouts of G .

Edge hide-outs. Let $s \in \mathbb{N}_{\geq 1}^+$ and $k \in \mathbb{N}$. A (k, s) -*edge-hide-out* in a graph G is any set $R \subseteq V(G)$ such that, for every $x \in R$, $\mathbf{supp}_G(s, x, R \setminus \{x\}) \geq k$. A (k, s) -*edge-hide-out* S is *maximal* if there is no other (k, s) -*edge-hide-out* S' with $S \subsetneq S'$. It is easy to verify that every graph contains a unique maximal (k, s) -edge-hide-out.

(k, s) -edge-hide-outs can be seen as obstructions to small s -edge-degeneracy. In particular we prove the following min-max theorem, characterizing the search game that we defined in Subsection 2.1.

Theorem 1 Let G be a graph and let $s \in \mathbb{N}_{\geq 1}^+$ and $k \in \mathbb{N}$. The following three statements are equivalent.

- (1) $\mathbf{cc}_s(G) \leq k$, i.e., there is a cop strategy f on G of cost less than k , such that for every robber strategy R on G , (f, R) is cop-winning.
- (2) G has no $(k + 1, s)$ -edge-hide-out.
- (3) $\delta_e^s(G) \leq k$.

Also, we settle the computational complexity of the s -edge-degeneracy δ_e^s as follows.

Theorem 2 If $s \in \{1, 2, 3, \infty\}$, then the problem that, given a graph G and a $k \in \mathbb{N}$, asks whether $\delta_e^s(G) \leq k$, is polynomially solvable, while it is NP-complete if $s \in \mathbb{N}_{\geq 4}$.

3 A structural theorem for edge-admissibility

3.1 Edge-admissibility

The *2-admissibility* of a graph G was defined in [5, 2] as the minimum k for which there exists a layout $L = \langle v_1, \dots, v_n \rangle$ of $V(G)$ such that for every $i \in [n]$ there are at most k vertex-disjoint paths from v_i to $L_{\leq i-1}$ in G . If in this definition we replace “vertex-disjoint” by “edge-disjoint” we have an edge analogue of the admissibility invariant that, because of Menger’s theorem is the same invariant as δ_e^∞ . This encourages us to alternatively refer to $\delta_e^\infty(G)$ as the *edge-admissibility* of the graph G .

The purpose of this section is to give a structural characterization for graphs of bounded edge-admissibility. For this we need first a series of definitions. Analogous structural results for the notion of (vertex)- ∞ -admissibility were given by Zdeněk Dvořák in [3, Theorem 6].

Immersion. Given a graph G and two incident edges e and f of G (i.e., edges with a common endpoint) the result of *lifting e and f in G* is the graph obtained from G after removing e and f and then adding the edge formed by the symmetric difference of e and f . We say that a graph H is an *immersion* of a graph G , denoted by $H \leq G$, if a graph isomorphic to H can be obtained from some subgraph of G after a series of liftings of incident edges. Given a graph H , we define the class of *H -immersion free graphs* as the class of all graphs that do not contain H as an immersion.

Edge sums. Given a graph G and a vertex v , we define $E_G(v)$ as the multi-set of all edges of G that are incident to v .

Let G_1 and G_2 be graphs, let v_1, v_2 be vertices of $V(G_1)$ and $V(G_2)$ respectively such that $k = \mathbf{edeg}_{G_1}(v_1) = \mathbf{edeg}_{G_2}(v_2)$, and consider a bijection $\sigma : E_{G_1}(v_1) \rightarrow E_{G_2}(v_2)$, where $E_{G_1}(v_1) = \{e_1^i \mid i \in [k]\}$. We define the *k -edge sum of G_1 and G_2 on v_1 and v_2 , with respect to σ* , as the graph G obtained if we take the disjoint union of G_1 and G_2 , identify v_1 with v_2 , and then, for each $i \in \{1, \dots, k\}$, lift e_1^i and $\sigma(e_1^i)$ to a new edge e^i and remove the vertex v_1 . We say that G is a *($\leq k$)-edge sum of G_1 and G_2* if either G is the disjoint union of G_1 and G_2 or there is some $k' \in [k]$, two vertices v_1 and v_2 , and a bijection σ as above such that G is the k -edge sum of G_1 and G_2 on v_1 and v_2 , with respect to σ .

Let \mathcal{G} be some graph class. We recursively define the *($\leq k$)-sum closure of \mathcal{G}* , denoted by $\mathcal{G}^{(\leq k)}$, as the set of graphs containing every graph $G \in \mathcal{G}$ and every graph G that is the ($\leq k$)-edge sum of two graphs G_1 and G_2 in \mathcal{G} where $|V(G_1)|, |V(G_2)| < |V(G)|$.

A graph G has *almost k -bounded edge-degree* if all its vertices, except possibly from one, have edge degree at most k . We denote this class of graphs by \mathcal{A}_k .

Given a $k \in \mathbb{N}_{\geq 1}$, we denote by θ_k the graph with two vertices and k parallel edges between them. We prove the following structural characterization of the graphs excluding θ_{k+1} as an immersion.

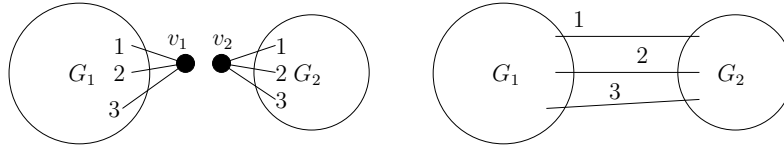

Figure 1: The graphs G_1 and G_2 and the graph created after the edge-sum of G_1 and G_2 .

Theorem 3 For every graph G and $k \in \mathbb{N}$, G is θ_{k+1} -immersion free if and only if $G \in \mathcal{A}_k^{(\leq k)}$.

It is easy to see that if $\theta_{k+1} \leq G$, then $\delta_e^\infty(G) > k$. We prove the following approximate version of the opposite direction.

Theorem 4 Let G be a graph and $k \in \mathbb{N}_{\geq 1}$. If $\theta_{k+1} \not\leq G$, then $\delta_e^\infty(G) \leq 2k - 1$.

Based on Theorems 3 and 4 we are able to prove our main structural result on edge-admissibility that is the following.

Theorem 5 For every graph G and $k \in \mathbb{N}_{\geq 0}$, if $\delta_e^\infty(G) \leq k$, then G can be constructed by almost k -bounded edge-degree graphs after a series of $(\leq k)$ -edge sums, i.e., $G \in \mathcal{A}_k^{(\leq k)}$. Conversely, for every $k \in \mathbb{N}_{\geq 1}$, every graph in $\mathcal{A}_k^{(\leq k)}$ has edge-admissibility at most $2k - 1$.

References

- [1] Hans L. Bodlaender, Thomas Wolle, and Arie M. C. A. Koster. Contraction and treewidth lower bounds. *J. Graph Algorithms Appl.*, 10(1):5–49 (electronic), 2006.
- [2] G.T. Chen and R.H. Schelp. Graphs with linearly bounded ramsey numbers. *Journal of Combinatorial Theory, Series B*, 57(1):138 – 149, 1993.
- [3] Zdeněk Dvořák. A stronger structure theorem for excluded topological minors. *arXiv:1209.0129*, 2012.
- [4] Martin Grohe, Stephan Kreutzer, Roman Rabinovich, Sebastian Siebertz, and Konstantinos Stavropoulos. Colouring and covering nowhere dense graphs. In *Graph-Theoretic Concepts in Computer Science - 41st International Workshop, WG 2015, Garching, Germany, June 17-19, 2015, Revised Papers*, pages 325–338, 2015.
- [5] Hal A. Kierstead and William T. Trotter. Planar graph coloring with an uncooperative partner. In *Planar Graphs, Proceedings of a DIMACS Workshop, New Brunswick, New Jersey, USA, November 18-21, 1991*, pages 85–94, 1991.
- [6] Lefteris M. Kirousis and Dimitrios M. Thilikos. The linkage of a graph. *SIAM J. Comput.*, 25(3):626–647, 1996.
- [7] David W. Matula. A min–max theorem for graphs with application to graph coloring. *SIAM Reviews*, 10:481–482, 1968.
- [8] Jaroslav Nešetřil and Patrice Ossona de Mendez. *Sparsity - Graphs, Structures, and Algorithms*, volume 28 of *Algorithms and combinatorics*. Springer, 2012.
- [9] Jaroslav Nešetřil and Patrice Ossona de Mendez. Fraternal augmentations, arrangeability and linear ramsey numbers. *European Journal of Combinatorics*, 30(7):1696 – 1703, 2009. EuroComb’07: Combinatorics, Graph Theory and Applications.
- [10] David Richerby and Dimitrios M. Thilikos. Searching for a visible, lazy fugitive. *SIAM J. Discrete Math.*, 25(2):497–513, 2011.
- [11] Daniel Weißauer. On the block number of graphs. *arXiv:1702.04245*, 2017.

A 3-edge-coloring algorithm

*Robert Lukořka*¹ and *Jakub Tětek*²

¹ Faculty of Mathematics, Physics and Informatics, Comenius University, Slovakia

² Faculty of Mathematics and Physics, Charles University, Czech Republic

EXTENDED ABSTRACT

Introduction. Due to Vizing's theorem [6] subcubic graphs have chromatic index at most four. Deciding, whether the chromatic index is 1, 2, or at least three is easy. On the other hand deciding whether the chromatic index is 3 or 4 is a well known NP-hard problem [4]. As if a graph has a vertex of degree at least four, then it's chromatic index is at least four, only graphs of maximal degree three are of interests while deciding 3-edge-colorability. Cubic graphs with bridges have chromatic index 4, thus only bridgeless cubic graphs are of interest while deciding 3-edge-colorability. Bridgeless cubic graphs that are not 3-edge colorable are called *snarks*. Snarks form an intriguing class of cubic graphs. Many important problems (e.g. Four color theorem, Five-Flow conjecture, Cycle double cover conjecture) can be reduced naturally into a problem concerning snarks. That is why are snarks studied both theoretically and computationally [2]. Fast algorithms to decide 3-edge-colorability and compute several related invariants are therefore of substantial interests in the study of snarks.

Until now, the asymptotically fastest algorithm to decide 3-edge-colorability of a subcubic graph was proposed by Kowalik [5] and it runs in $O(1.344^{|V(G)|})$ time. Kowalik's paper also notes, that there is a $O(6^{(1/6+\varepsilon)\cdot|V(G)|}) = O(1.349^{|V(G)|})$ -algorithm that uses dynamic programming with path decomposition provided by the algorithm of Fomin and Høie [3].

A *path decomposition* of a graph G is a sequence (X_1, X_2, \dots, X_k) of subsets of $V(G)$, for some integer k , such that each vertex of G occurs contiguously in the sequence and for each edge both its endvertices are in at least one set together. The *width* of this decomposition is $\max_{i=1}^k |X_i| - 1$. The *pathwidth* of a graph G is the minimal width of a path decomposition of G . Fomin and Høie showed [3] that for every $\varepsilon > 0$ there exists a polynomial-time algorithm that finds a path decomposition of a cubic graph G of width at most $(1/6 + \varepsilon) \cdot |V(G)|$. To avoid degenerate cases we will consider only path decompositions with $k \leq |E(G)|$ (otherwise the path decomposition contains sets that can be removed).

In our paper we refine the dynamic programming approach hinted by Kowalik and show that for a given path decomposition D of a subcubic graph G , we can decide whether G is 3-edge-colourable in time $O(|V(G)| \cdot 3^{w(D)})$. Thus for each $\varepsilon > 0$, there is an algorithm that decides 3-edge-colorability of G in time $O(3^{(1/6+\varepsilon)\cdot|V(G)|}) = O(1.201^{|V(G)|})$. We also propose related algorithms that calculate *resistance* (the least number of vertices that has to be removed to make a cubic graph 3-edge colorable), *weak oddness* (the least number of odd factors in an even factor of a cubic graph), and *strong oddness* (the least number of odd circuits in a 2-factor of a cubic graph), in similar running time.

Throughout this paper, we fix G to be the graph whose 3-edge colorability we want to decide and we denote n the order and m the size of G .

Deciding 3-edge-colorability of cubic graphs. For simplicity, in this section we assume that the graph G is cubic (the ideas here can be straightforwardly extended to subcubic graphs) and loopless (graphs with loops are not colorable by definition). To ease the algorithm description we assume that instead of an ordinary path decomposition of G we use a *decomposition pair* $((X_1, X_2, \dots, X_m), f)$, where (X_1, X_2, \dots, X_m) is a path decomposition of G and f is a bijective mapping from $\{1, \dots, m\}$ to $E(G)$ such that for each $i \in \{1, \dots, m\}$ both end-vertices of $f(i)$ are in X_i . Such a special path decomposition can be constructed from an arbitrary path decomposition straightforwardly. Using the algorithm of Fomin and Høie we can, in polynomial time, calculate a decomposition pair $((X_1, X_2, \dots, X_m), f)$, such that the path decomposition (X_1, X_2, \dots, X_m) of G has width at most $(1/6 + \varepsilon) \cdot n$.

The *subgraph at step j* , denoted by G_j is a subgraph of G that has the same vertex-set as G but it contains only edges $f(i)$ for $i \in \{1, \dots, j-1\}$. The *degree of v at step j* , denoted by

$d_j(v)$, equals the degree of v in G_j . Note that due to the definition of path decomposition, vertices that are not in X_j have degree zero or three at step j . Let $D_{1,j}$ and $D_{2,j}$ be the sets of vertices from X_j that have degree one and two, respectively, at step j . Let $r_j = |D_{1,j} \cup D_{2,j}|$.

All edge colorings in this section are proper 3-edge-colorings and use colors 0, 1, and 2. We will call such a coloring simply *coloring*. Let c be a coloring of G_j . For a vertex $v \in D_{1,j}$, the *color of v in c at step j* , is the unique color of the edge incident with v in G_j . For a vertex $v \in D_{2,j}$, the *color of v in c at step j* is the unique color that is not present on the edges incident with v in G_j . In both cases we denote the color of v in c at step j by $c_j(v)$. The main idea of our algorithm compared to the ordinary dynamic programming approach is that at each step j it is sufficient to maintain only information about the tuples of admissible colors of vertices from $D_{1,j} \cup D_{2,j}$.

Our dynamic programming at step j , $j \in \{1, \dots, m+1\}$, stores two data structures. First is the *ordering array* o_j that orders the vertices from $D_{1,j} \cup D_{2,j}$ (thus the array contains r_j distinct vertices from X_j). Let o be an ordering array and v be a vertex. If v is in o , then $o - v$ denotes the ordering array that contains all elements of o other than v in the same order as they were in o . If v is not in o , then $o \cdot v$ denotes the ordering array created from o by adding v as the last element.

Second structure uses a special bitarray, whose length is a power of 3. To index in such a bitarray b of length 3^k , instead of ordinary indices, we use sequences $a_1 a_2 \dots a_{k-1} a_k$ of ternary digits, that is for each $i \in \{1, \dots, k\}$ we have $a_i \in \{0, 1, 2\}$ and the sequence $b[a_1 \dots a_k]$ represents the $(\sum_{i=1}^k a_i \cdot 3^{i-1})$ -th bit of b . For each integer k let *false*(k) be the bitarray of length 3^k that contains only *false* values. For two bitarrays b_1 and b_2 , $b_1 \cdot b_2$ denotes the concatenation and if the two arrays have equal length then $b_1 \mid b_2$ denotes the bitwise or operation.

The second structure in our dynamic programming, the *coloring array* b_j , is a bitarray defined as follows. It has length 3^{r_j} . The value of $b_j[a_1 \dots a_{r_j}]$ is true if and only if G_j has a coloring c such that for each $i \in \{1, \dots, r_j\}$ the color $c_j(o_j[i]) = a_i$.

Let $i, i' \in \{0, 1, 2\}$ and $v, v' \in D_{1,j} \cup D_{2,j}$, $v \neq v'$. Let k and k' be the positions of v and v' in o_j , respectively. Assume without loss of generality that $k' > k$. We define $b_j\{v, i\}$ and $b_j\{v, v', i, i'\}$ to be bitarrays of length 3^{r_j-1} and 3^{r_j-2} , respectively, such that for each $a_1, \dots, a_{r_j} \in \{0, 1, 2\}$:

- $b_j\{v, i\}[a_1 \dots a_{k-1} a_{k+1} \dots a_{r_j}] = b_j[a_1 \dots a_{k-1} i a_{k+1} \dots a_{r_j}]$;
- $b_j\{v, v', i, i'\}[a_1 \dots a_{k-1} a_{k+1} \dots a_{k'-1} a_{k'+1} \dots a_{r_j}] = b_j[a_1 \dots a_{k-1} i a_{k+1} \dots a_{k'-1} i' a_{k'+1} \dots a_{r_j}]$.

Now we are finally in position to describe the algorithm. Clearly, $o_1 = ()$ and $b_1 = (\text{true})$. Then for each $j \in \{1, \dots, m\}$ we compute o_{j+1} and b_{j+1} as follows. Let u and v be two endvertices of $f(j)$. We may without loss of generality assume that $d_j(u) \leq d_j(v)$.

As when we reduce coloring of G_{j+1} to G_j it is still a coloring, every coloring of G_{j+1} can be obtained from a coloring of G_j by setting the color of the edge $f(j)$.

We consider six cases according to $d_j(u)$ and $d_j(v)$.

- $d_j(u) = 0, d_j(v) = 0$:

Let $o_{j+1} = o_j \cdot v \cdot u$. Consider a coloring c of G_j . We can extend it into a coloring c' of G_{j+1} by setting $f(j) = x$, for arbitrary $x \in \{0, 1, 2\}$. For every $w \in D_{1,j} \cup D_{2,j}$, $c_j(w) = c'_{j+1}(w)$. For vertices u and v we have $c'_{j+1}(u) = c'_{j+1}(v) = x$. Thus we can compute b_{j+1} as

$$\begin{aligned} b_{j+1} &= b_j \cdot \text{false}(r_j) \cdot \text{false}(r_j) \\ &\cdot \text{false}(r_j) \cdot b_j \cdot \text{false}(r_j) \\ &\cdot \text{false}(r_j) \cdot \text{false}(r_j) \cdot b_j. \end{aligned}$$

- $d_j(u) = 0, d_j(v) = 1$:

Consider the coloring c of G_j and let x be the color of v in c at step j . To extend this coloring to G_{j+1} we have to color the edge $f(j)$ with a color y other than x . We name the extended coloring c' . We have $c'_{j+1}(u) = y$ and $c'_{j+1}(v)$ is the unique color from $\{0, 1, 2\} - \{x, y\}$. Thus we can compute b_{j+1} as

$$\begin{aligned} o_{j+1} &= (o_j - v) \cdot v \cdot u \\ b_{j+1} &= \text{false}(r_j - 1) \cdot b_j\{v, 2\} \cdot b_j\{v, 1\} \\ &\quad \cdot b_j\{v, 2\} \cdot \text{false}(r_j - 1) \cdot b_j\{v, 0\} \\ &\quad \cdot b_j\{v, 1\} \cdot b_j\{v, 0\} \cdot \text{false}(r_j - 1). \end{aligned}$$

- $d_j(u) = 0, d_j(v) = 2$:

Consider the coloring c of G_j and let x be the color of v in c at step j . To extend this coloring to G_{j+1} we have to color the edge $f(j)$ with a color x . We name the extended coloring c' . We have $c'_{j+1}(u) = x$. Thus we can compute b_{j+1} as

$$\begin{aligned} o_{j+1} &= (o_j - v) \cdot u \\ b_{j+1} &= b_j\{v, 0\} \cdot b_j\{v, 1\} \cdot b_j\{v, 2\}. \end{aligned}$$

- $d_j(u) = 1, d_j(v) = 1$:

Consider the coloring c of G_j and let $x = c_j(u)$ and $y = c_j(v)$. If $x = y$, then to extend c to G_{j+1} we have to color the edge $f(j)$ with a color z other than x . Let z' be the third color. We have $c'_{j+1}(u) = c'_{j+1}(v) = z$. On the other hand, if $x \neq y$, then the third color has to be used to color $f(j)$. In this case we have $c'_{j+1}(u) = y$ and $c'_{j+1}(v) = z$. Thus we can compute b_{j+1} as

$$\begin{aligned} o_{j+1} &= (o_j - u - v) \cdot v \cdot u \\ b_{j+1} &= (b_j\{u, v, 1, 1\} \mid b_j\{u, v, 2, 2\}) \cdot b_j\{u, v, 0, 1\} \cdot b_j\{u, v, 0, 2\} \\ &\quad \cdot b_j\{u, v, 1, 0\} \cdot (b_j\{u, v, 0, 0\} \mid b_j\{u, v, 2, 2\}) \cdot b_j\{u, v, 1, 2\} \\ &\quad \cdot b_j\{u, v, 2, 0\} \cdot b_j\{u, v, 2, 1\} \cdot (b_j\{u, v, 0, 0\} \mid b_j\{u, v, 1, 1\}). \end{aligned}$$

- $d_j(u) = 1, d_j(v) = 2$:

Consider the coloring c of G_j and let $x = c_j(u)$ and $y = c_j(v)$. We can extend the coloring only if $x \neq y$ and we have to color the edge $f(j)$ with color y . Let z be the color other than x and y . We have $c'_{j+1}(u) = z$. Thus we can compute b_{j+1} as

$$\begin{aligned} o_{j+1} &= (o_j - u - v) \cdot u \\ b_{j+1} &= (b_j\{u, v, 1, 2\} \mid b_j\{u, v, 2, 1\}) \\ &\quad \cdot (b_j\{u, v, 0, 2\} \mid b_j\{u, v, 2, 0\}) \\ &\quad \cdot (b_j\{u, v, 0, 1\} \mid b_j\{u, v, 1, 0\}). \end{aligned}$$

- $d_j(u) = 2, d_j(v) = 2$:

Consider the coloring c of G_j and let $x = c_j(u)$ and $y = c_j(v)$. We can extend the coloring only if $x = y$ and we have to color the edge $f(j)$ with color x . We can compute b_{j+1} as

$$\begin{aligned} o_{j+1} &= (o_j - u - v) \\ b_{j+1} &= (b_j\{u, v, 0, 0\} \mid b_j\{u, v, 1, 1\} \mid b_j\{u, v, 2, 2\}). \end{aligned}$$

After m steps the coloring array has just one element that determines whether the graph admits a 3-edge-coloring.

Implementation and extensions. Our algorithm can be easily modified to allow various calculation typical in study of subcubic graphs and snarks, among others:

- deciding if a partial coloring is extensible to the whole graph,
- compute the set of admissible colors on halfedges,
- determine the resistance of a cubic graph,
- determine the strong and weak oddness of a cubic graph.

To determine invariants like resistance, oddness and weak oddness one has to save k coloring arrays, where k is a bound on the parameter for the studied graph. The i -th coloring array contains information on which color tuples are admissible if we allow $i - 1$ specific errors in the coloring. For resistance, an error in the coloring means that an edge may have different colors at its ends. For strong oddness, an error in the coloring means that an edge may have color 1 at one end and color 2 at the other. For weak oddness, an error in the coloring means that an edge may have color 1 at one end and color 2 at the other, or that a vertex is incident with three edges that have color 0.

In our implementation we replaced the Fomin-Høie algorithm (which is quite hard to implement) by a simple path decomposition heuristics: we start with a vertex and then we repeatedly find shortest ears and expand the decomposition pair so it contains the edges of the shortest ear. We tested our approach on random 120 vertex cubic graphs. This simple heuristic produced path decompositions of widths between 15 and 20. Our implementation (which definitely can be improved) was able to deal even with the (rare) path decompositions of width 20, it required one and half minute (single threaded, 3MHz) and 5GB RAM.

Note that there are various heuristics that find 3-edge-colouring of random graphs easily. Thus one can expect that for “interesting” instances of the problem, one can find path decompositions of even shorter width. Indeed, with our colleagues we already used the algorithm successfully to verify properties of several quite large graphs (e.g. graphs from [1]).

Acknowledgements. The first author was supported by the grants VEGA 1/0876/16, VEGA 1/0813/18, and by APVV-15-0220. The second author was supported by the Czech Science Foundation (GACR) project 17-10090Y "Network optimization".

References

- [1] I. Allie. Oddness to resistance ratios in cubic graphs. **Discrete Mathematics** 342:387–392, 2019.
- [2] G. Brinkmann, J. Goedgebeur, J. Häggglund, K. Markström. Generation and properties of snarks. **Journal of Combinatorial Theory B** 103:468–488, 2013.
- [3] F. V. Fomin, K. Høie. Pathwidth of cubic graphs and exact algorithms. **Information Processing Letters** 97:191–196, 2006.
- [4] I. Holyer. The NP-Completeness of Edge-Colouring. **SIAM Journal on Computing** 10:718–720, 1981.
- [5] Ł. Kowalik. Improved edge-coloring with three colors. **Theoretical Computer Science** 410:3733–3742, 2009.
- [6] V. G. Vizing. On the estimate of the chromatic class of a p -graph. **Diskret. Anal.** 3:25–30, 1964.

Medial graphs of bipartite plane graphs are 3-choosable

François Dross¹, Mária Maceková², Borut Lužar³, and Roman Soták²

¹ LIRMM, Université de Montpellier & CNRS, France

² Faculty of Science, P.J. Šafárik University in Košice, Slovakia

³ Faculty of Information Studies, Novo mesto, Slovenia

EXTENDED ABSTRACT

In this talk we consider the problem of the 3-colorability of a subclass of 4-regular planar graphs. Deciding whether a planar graph (even of maximum degree 4) is 3-colorable is NP-complete [6]. Heawood [9] proved that a plane triangulation is 3-colorable if and only if all its vertices have even degrees. On the other hand, a wellknown result by Grötzsch's [7] shows that if there are no cycles of length 3 in a planar graph, then it is 3-colorable. This result was later improved by Grünbaum [8] to planar graphs with at most three triangles.

Allowing some triangles in a graph, but still retaining 3-colorability yielded two intriguing conjectures. Havel conjectured that a planar graph that contains only triangles that are sufficiently far apart is 3-colorable. This conjecture was proved by Dvořák, Král, and Thomas [4]. The second conjecture is due to Steinberg, who conjectured that every planar graph without cycles of length 4 and 5 is 3-colorable. The conjecture was disproved by Cohen-Addad et al [2]; however a number of weaker results have been proved.

All the problems listed above are even harder in a more general setting of list coloring. As shown by Voigt [12], planar graphs are not 4-choosable; Thomassen [10] proved that they are 5-choosable. An equivalent of Grötzsch's result does not hold in the list setting; as shown by Voigt [13], there are triangle-free planar graphs which are not 3-choosable. Thomassen [11] however proved that girth 5 is a sufficient condition for their 3-choosability.

An analogue of Havel's conjecture hence requires cycles of length 3 and also 4 to be sufficiently distant. Dvořák [3] proved that distance 26 between them is sufficient. The list-version of Steinberg's conjecture clearly requires more excluded cycles. Dvořák and Postle [5] showed that planar graphs without cycles of lengths from 4 to 8 are 3-choosable. It is still not known if it suffices to forbid only cycles from 4 to 7 or even from 4 to 6.

In this talk, we prove the following:

Theorem 1 *Every medial graph (with eventual loops removed) of a bipartite plane graph is 3-choosable.*

Let G be a bipartite plane graph with $\delta(G) \leq 2$. The *medial graph* $M(G)$ is a graph with the vertex set $V(M(G)) = E(G)$ and two vertices u and v being adjacent if the edges of G corresponding to u and v appear successively on the boundary of some face of G . Hence, $M(G)$ is 4-regular, it can have close triangles (even incident), and it has no short cycles forbidden.

There are two types of faces in $M(G)$: the ones corresponding to the vertices of G (we call them *black*), and the ones corresponding to the faces of G (we call them *white*). Notice that all white faces have even length, since G is bipartite. Moreover, every edge in $M(G)$ is incident to two faces, one black and one white (see the left graph in Figure 1 for an example).

Let $\vec{M}(G)$ be a directed graph obtained from $M(G)$ by directing the edges such that each edge has its black face on the left hand side when going from its initial vertex to its terminal vertex. This in particular means that every vertex has precisely two incoming and two outgoing edges, and therefore $d^-(v) = d^+(v) = 2$ for every $v \in V(\vec{M}(G))$.

For $\vec{M}(G)$ we use the following well-known result due to Alon and Tarsi [1].

Theorem 2 (Alon & Tarsi, 1992) *Let D be a directed graph, and let L be a list-assignment such that $|L(v)| \geq d_D^+(v) + 1$ for each $v \in V(D)$. If $E^e(D) \neq E^o(D)$, then D is L -colorable.*

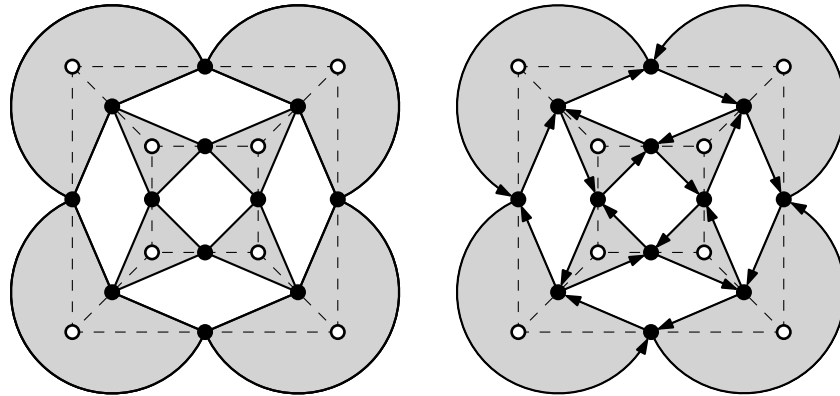

Figure 1: The left graph is the medial graph $M(Q_3)$ of the cube Q_3 ; its vertices and edges are depicted as full circles and solid edges, while the vertices and edges of Q_3 are depicted with empty circles and dashed edges. The black faces of $M(Q_3)$ are shaded. The right graph is the directed graph $\vec{M}(Q_3)$ such that the edges have a black face always on their left hand side.

It can be shown that every odd Eulerian spanning subgraph of $\vec{M}(G)$ can be injectively mapped to an even Eulerian spanning subgraph of $\vec{M}(G)$; and that there is an even Eulerian subgraph of $\vec{M}(G)$ to which no odd subgraph is mapped, and thus fulfill the assumptions of Theorem 2. That will imply 3-choosability of $M(G)$.

References

- [1] N. Alon, M. Tarsi. Colorings and orientations of graphs. **Combinatorica** 12:125–134, 1992.
- [2] V. Cohen-Addad, M. Hebdige, Daniel Král', Z. Li, E. Salgado. Steinberg's Conjecture is false. **J. Combin. Theory Ser. B** 122:452–456, 2017.
- [3] Z. Dvořák. 3-choosability of planar graphs with (≤ 4) -cycles far apart. **J. Combin. Theory Ser. B** 104:28–59, 2014.
- [4] Z. Dvořák, D. Král', R. Thomas. Three-coloring triangle-free graphs on surfaces V. Coloring planar graphs with distant anomalies. **ArXiv Preprint**, <http://arxiv.org/abs/0911.0885v3>, 2016.
- [5] Z. Dvořák, L. Postle. Correspondence coloring and its application to list-coloring planar graphs without cycles of lengths 4 to 8. **J. Combin. Theory Ser. B** 129:38–54, 2018.
- [6] M. R. Garey, D. S. Johnson, L. Stockmeyer. Some simplified NP-complete graph problems. **Theoret. Comput. Sci.** 1:237–267, 1976.
- [7] H. Grötzsch. Ein Dreifarbensatz für dreikreisfreie Netze auf der Kugel. **Wiss. Z. Martin-Luther-Univ. Halle-Wittenberg Math.-Natur.** 8:109–120, 1959.
- [8] B. Grünbaum. Acyclic coloring of planar graphs. **Israel J. Math.** 14:390–412, 1973.
- [9] P. J. Heawood. On the four-colour map theorem. **Quart. J. Pure Appl. Math.** 29:270–285, 1898.
- [10] C. Thomassen. Every Planar Graph Is 5-Choosable. **J. Combin. Theory Ser. B** 62:180–181, 1994.

- [11] C. Thomassen. 3-List-Coloring Planar Graphs of Girth 5. **J. Combin. Theory Ser. B** 64:101–107, 1995.
- [12] M. Voigt. List colourings of planar graphs. **Discrete Math.** 120:215–219, 1993.
- [13] M. Voigt. A not 3-choosable planar graph without 3-cycles. **Discrete Math.** 146:325–328, 1995.

Berge-Tutte type formula for an f -leaf-tree

*Shun-ichi Maezawa*¹ and *Haruhide Matsuda*²

¹ Graduate School of Environment and Information Sciences
Yokohama National University,
791 Yokohama, Kanagawa, Japan

² Department of Information and Communication Engineering
Shibaura Institute of Technology,
307 Fukasaku, Saitama, Japan

EXTENDED ABSTRACT

1 Introduction

We consider finite undirected graphs with neither loops nor multiple edges. For a graph G , $V(G)$ denotes the vertex set of G and $E(G)$ denotes the edge set of G . The order of G is denoted by $|G|$. For a positive integer m , we denote by $K_{1,m}$ a star with m end-vertices and C_m a cycle of order $m \geq 3$. For a set of undirected graphs \mathcal{H} , a spanning subgraph F of a graph G is called an \mathcal{H} -factor if every connected component of F is isomorphic to some element of \mathcal{H} . Tutte showed the characterization on the existence of perfect matchings in graphs [5]. Berge [2] extended Tutte's theorem to a min-max formula for the maximum order of a matching in graphs. For a graph G , $o(G)$ denotes the number of odd components (those having an odd number of vertices).

Theorem 1 (Tutte [5]) *A graph G has a perfect matching if and only if*

$$o(G - S) \leq |S| \quad \text{for all } S \subseteq V(G).$$

Berge [2] extended the above Tutte's theorem to a min-max formula, known as the Berge-Tutte formula, for the maximum order of a matching in a graph.

Theorem 2 (Berge [2]) *Let G be a graph. The order of a maximum matching of G equals*

$$|V(G)| - \max_{X \subseteq V(G)} \{o(G - X) - |X|\}.$$

Let G be a graph and f an integer-valued function defined on $V(G)$ such that $f(x) \geq 1$ for all $x \in V(G)$. Then a subgraph of G is called an f -star if it is isomorphic to the star $K_{1,t}$ such that the degree t of its center x satisfies $1 \leq t \leq f(x)$. Berge and Las Vergnas obtained the necessary and sufficient condition for graphs to have a spanning subgraph each of whose components is an f -star. Note that $i(G)$ stands for the number of isolated vertices in a graph G .

Theorem 3 (Berge and Las Vergnas [3]) *Let G be a graph and f an integer-valued function defined on $V(G)$ such that $f(x) \geq 2$ for all $x \in V(G)$. Then G has a spanning subgraph each of whose components is an f -star if and only if*

$$i(G - S) \leq \sum_{x \in S} f(x) \quad \text{for all } S \subseteq V(G).$$

Theorem 4 (Berge and Las Vergnas [3]) *Let G be a graph and f an integer-valued function defined on $V(G)$ such that $f(x) \geq 1$ for all $x \in V(G)$. Then G has a spanning subgraph of G every component of which is either an f -star or an odd cycle C with $f(x) = 1$ for every vertex $x \in V(C)$ if and only if*

$$i(G - S) \leq \sum_{x \in S} f(x) \quad \text{for all } S \subseteq V(G).$$

A vertex of a tree T with degree one is often called a *leaf* and the *leaf degree* of a vertex $x \in V(T)$ is defined as the number of leaves in T adjacent to x , and is denoted by $\text{leaf}_T(x)$. Let f be an integer-valued function defined on $V(G)$ such that $f(x) \geq 0$ for all $x \in V(G)$. A tree T of G is said to be an f -leaf-tree of G if the leaf degree of each vertex $x \in V(T)$ is at most $f(x)$. For a positive integer m , an f -leaf-tree is an m -leaf-tree if $f(x) = m$ for any $x \in V(G)$.

A spanning subgraph each of whose components is an f -star can be regarded as a spanning forest with bounded leaf degree. Thus we are interested in the similar criterions for a spanning ‘tree’ with bounded leaf degree. In fact, Kaneko gave a necessary and sufficient condition for graphs to have a spanning m -leaf-tree, which gives the similar criterion with Theorems 3 and 4.

Theorem 5 (Kaneko [4]) *Let m be an integer with $m \geq 1$. A connected graph G has a spanning m -leaf-tree if and only if for every nonempty subset $S \subseteq V(G)$,*

$$i(G - S) \leq (m + 1)|S| - 1$$

unless G is isomorphic to C_3 and $m = 1$.

2 Main Results

Motivated by Kaneko’s theorem, we obtain two results on an f -leaf-tree in a graph.

Our first theorem is a necessary and sufficient condition for graphs to have a spanning f -leaf-tree. The above Kaneko’s result assumes $m \geq 1$, that is, the upper bound of each leaf degree is at least one, but our result contains the case when the leaf degrees of some vertices are zero.

Theorem 6 *Let G be a connected graph and f an integer-valued function defined on $V(G)$ such that $f(x) \geq 0$ for all $x \in V(G)$. Suppose that the set of vertices x with $f(x) = 0$ is independent in G . Then G has a spanning f -leaf-tree if and only if for every nonempty subset $S \subseteq V(G)$,*

$$i(G - S) \leq \sum_{x \in S} (f(x) + 1) - 1$$

unless G is isomorphic to C_3 such that $f(x_1) \leq 1 = f(x_2) = f(x_3)$ for each $x_i \in V(C_3)$ with $i = 1, 2, 3$.

Our second result is the maximum order of an f -leaf-tree in a graph, which is the Berge-Tutte type theorem for an f -leaf-tree.

Theorem 7 *Let G be a connected graph and f an integer-valued function defined on $V(G)$ such that $f(x) \geq 1$ for all $x \in V(G)$. For each integer k with $1 \leq k \leq |V(G)|$, define a function $g(k)$ as follows.*

$$g(k) := \max_{\substack{S_1, \dots, S_k \subseteq V(G) \\ S_i \neq \emptyset \text{ for } 1 \leq i \leq k \\ S_i \cap S_j = \emptyset \text{ for } 1 \leq i < j \leq k}} \sum_{j=1}^k \left(i(G - S_j) - \sum_{x \in S_j} (f(x) + 1) + 1 \right).$$

Then the maximum order of an f -leaf-tree of G is given by

$$|V(G)| - \max_{1 \leq k \leq |V(G)|} \{g(k), 0\}$$

unless G is isomorphic to C_3 such that $f(x_1) = f(x_2) = f(x_3) = 1$ for each $x_i \in V(C_3)$ with $i = 1, 2, 3$.

References

- [1] A. AMAHASHI AND M. KANO, Factors with given components, *Discrete Mathematics* **42** (1982) 1–6.
- [2] C. BERGE, Sur le couplage maximum d'un graphe, *C. R. Acad. Sci. Paris* **247** (1958) 258–259.
- [3] C. BERGE AND M. LAS VERGNAS, On the existence of subgraphs with degree constraints, *Nederl. Akad. Wetensch. Indag. Math.* **40** (1978) 165–176.
- [4] A. KANEKO, Spanning trees with constraints on the leaf degree, *Discrete Applied Mathematics* **115** (2001) 73–76.
- [5] W. T. TUTTE, The factorization of linear graphs, *J. London Math. Soc.* **22** (1947) 107–111.

Packing Directed Circuits Quarter-Integrally ¹

Tomáš Masařík ¹, *Irene Muzi* ³, *Marcin Pilipczuk* ¹,
Paweł Rzażewski ², and *Manuel Sorge* ¹

¹ University of Warsaw, Stefana Banacha 2, Warsaw, Poland

² Warsaw University of Technology, Koszykowa 75, Warsaw, Poland

³ Technische Universität Berlin, Straße des 17. Juni 135, Berlin, Germany

EXTENDED ABSTRACT

The celebrated Erdős-Pósa theorem [3] states that every undirected graph that does not admit a family of k vertex-disjoint cycles contains a feedback vertex set (a set of vertices hitting all cycles in the graph) of size $\mathcal{O}(k \log k)$. After being known for long as Younger’s conjecture, a similar statement for directed graphs has been proven in 1996 by Reed, Robertson, Seymour, and Thomas [8]. However, in their proof, the dependency of the size of the feedback vertex set on the size of vertex-disjoint cycle packing is not elementary.

We show that if we compare the size of a minimum feedback vertex set in a directed graph with *quarter-integral* cycle packing number, we obtain a polynomial bound. More precisely, we show that if in a directed graph G there is no family of k cycles such that every vertex of G is in at most *four* of the cycles, then there exists a feedback vertex set in G of size $\mathcal{O}(k^4)$. On the way there we prove a more general result about quarter-integral packing of subgraphs of high directed treewidth: for every pair of positive integers a and b , if a directed graph G has directed treewidth $\Omega(a^6 b^8 \log^2(ab))$, then one can find in G a family of a subgraphs, each of directed treewidth at least b , such that every vertex of G is in at most four subgraphs.

More precisely, we prove that if one compares the feedback vertex set number of a directed graph to the *quarter-integral* cycle packing number (i.e., the maximum size of a family of cycles in G such that every vertex lies on at most four cycles), one obtains a polynomial bound.

Theorem 1 *If a directed graph G does not contain a family of k cycles such that every vertex in G is contained in at most four cycles, then there exists a feedback vertex set in G of size $\mathcal{O}(k^4)$.*

Directed treewidth is a directed analog of the successful notion of treewidth, introduced in [7]. For a directed graph G , let $\text{fvs}(G)$, $\text{dtw}(G)$, and $\text{cp}(G)$ denote the feedback vertex set number, directed treewidth, and the cycle packing number of G , respectively. The following lemma is a direct consequence of [1, Lemma 4.2].

Lemma 2 *For a directed graph G it holds that $\text{fvs}(G) \leq (\text{dtw}(G) + 1) \text{cp}(G)$.*

In the light of Lemma 2 and since a directed grid minor of size k contains k vertex-disjoint cycles, the directed grid theorem of Kawarabayashi and Kreutzer [5] is a generalization of the directed Erdős-Pósa property due to Reed, Robertson, Seymour, and Thomas [8].

Theorem 1 is a direct corollary of Lemma 2 and the following statement that we prove.

Theorem 3 *If a directed graph G does not contain a family of k cycles such that every vertex in G is contained in at most four cycles, then $\text{dtw}(G) = \mathcal{O}(k^3)$.*

Furthermore, if one asks not for a cycle packing, but a packing of subgraphs of large directed treewidth, we prove the following packing result.

¹The conference version of this article will appear on ESA 2019 [6]. The full version is available on [arXiv:1907.02494](https://arxiv.org/abs/1907.02494) This research is a part of projects that have received funding from the European Research Council (ERC) under the European Union’s Horizon 2020 research and innovation programme Grant

Agreements 648527 (IM) and 714704 (all authors).   Tomáš Masařík is also affiliated with Charles University, Prague, Czech Republic. He was also supported by Charles University, student grant number SVV-2017-260452.

Theorem 4 *There exists an absolute constant c with the following property. For every pair of positive integers a and b , and every directed graph G of directed treewidth at least $c \cdot a^6 \cdot b^8 \cdot \log^2(ab)$, there are directed graphs G_1, G_2, \dots, G_a with the following properties:*

1. each G_i is a subgraph of G ,
2. each vertex of G belongs to at most four graphs G_i , and
3. each graph G_i has directed treewidth at least b .

Note that by setting $b = 2$ in Theorem 4, one obtains Theorem 3 with a slightly weaker bound of $\mathcal{O}(k^6 \log^2 k)$ and, consequently, Theorem 1 with a weaker bound of $\mathcal{O}(k^7 \log^2 k)$.

Theorem 4 should be compared to its undirected analog of Chekuri and Chuzhoy [2] that asserts that in an undirected graph G of treewidth at least $c \min(ab^2, a^3b)$ one can find a vertex-disjoint subgraphs of treewidth at least b . While we still obtain a polynomial bound, we can only prove the existence of a quarter-integral (as opposed to integral, i.e., vertex-disjoint) packing of subgraphs of high directed treewidth.

Preliminaries. Let $G = (V(G), E(G))$ be a directed graph and let A, B be subsets of $V(G)$ with $|A| = |B|$. A *linkage* from A to B in G is a set \mathcal{L} of $|A|$ pairwise vertex-disjoint paths in G , each with a starting vertex in A and ending vertex in B . The *order* of \mathcal{L} is $|\mathcal{L}| = |A|$. For $X, Y \subseteq V(G)$ and a linkage \mathcal{L} from X to Y , we denote $A(\mathcal{L}) := X$ and $B(\mathcal{L}) := Y$. For a path or a walk P , by $\text{start}(P)$ and $\text{end}(P)$ we denote the starting and ending vertex of P , respectively. A vertex set $W \subseteq V(G)$ is *well-linked* if for all subsets $A, B \subseteq W$ with $|A| = |B|$ there is a linkage \mathcal{L} of order $|A|$ from A to B in $G \setminus (W \setminus (A \cup B))$. Let \mathcal{L} and \mathcal{K} be linkages. The *intersection graph* of \mathcal{L} and \mathcal{K} , denoted by $I(\mathcal{L}, \mathcal{K})$, is the bipartite graph with the vertex set $\mathcal{L} \cup \mathcal{K}$ and an edge between a vertex in \mathcal{L} and a vertex in \mathcal{K} if the corresponding paths share at least one vertex. We say that G is d -degenerate if and only if every subgraph of G contains a vertex of degree at most d . In this paper we do not need the exact definition of directed treewidth. Instead, we rely on the following two results.

Lemma 5 ([7]) *Every directed graph G of directed treewidth k contains a well-linked set of size $\Omega(k)$.*

Lemma 6 ([5]) *There is an absolute constant c' with the following property. Let $\alpha, \beta \geq 1$ be integers and let G be a digraph of $\text{dtw}(G) \geq c' \cdot \alpha^2 \beta^2$. Then there exists a set of α vertex-disjoint paths P_1, \dots, P_α and sets $A_i, B_i \subseteq V(P_i)$, where A_i appears before B_i on P_i , both $|A_i|, |B_i| = \beta$, and $\bigcup_{i=1}^\alpha A_i \cup B_i$ is well-linked.*

We also need the following two auxiliary results. Note that a coloring in Lemma 7 can be arbitrary and is not necessarily proper.

Lemma 7 ([9, Lemma 4.3]) *Let $r \geq 2$, d be a real, and H be an r -colored graph with color classes V_1, \dots, V_r , such that for every i it holds that $|V_i| \geq 4e(r-1)d$ and for every $i \neq j$ the graph $H[V_i \cup V_j]$ is d -degenerate. Then there exists an independent set $\{x_1, \dots, x_r\}$ such that $x_i \in V_i$ for every $i \in [r]$.*

Lemma 8 ([4, Lemma 5.5]) *Let G be a digraph and P_1, \dots, P_k be disjoint paths such that each P_i consists of two subpaths A_i and B_i , where A_i precedes B_i . Furthermore, let $\{L_{i,j} : i, j \in [k], i \neq j\}$ be a set of pairwise disjoint paths, such that $L_{i,j}$ starts in B_i and ends in A_j . Then $\text{dtw}\left(\bigcup_i P_i \cup \bigcup_{i \neq j} L_{i,j}\right) \geq \frac{k}{8}$.*

Partitioning Lemma. Here, we develop a main technical tool that we use in the proof of Theorem 4. Intuitively, in a subcase of the proof, we will have a bipartite graph of large minimum degree which we partition into subgraphs induced by pairs of vertex sets (U_i, W_i) . These subgraphs will define the G_i from the statement of Theorem 4. To obtain a lower bound on the directed treewidth of G_i , we need that the parts (U_i, W_i) each induce a subgraph of large average degree. This will be achieved using the following lemma.

Lemma 9 Let $k, r \geq 1$ be two integers and let G be a bipartite graph with bipartition classes $X = \{x_1, x_2, \dots, x_a\}$ and $Y = \{y_1, y_2, \dots, y_b\}$ and minimum degree at least $1200 \cdot r \cdot k$. Then there are k sets U_1, U_2, \dots, U_k , and k sets W_1, W_2, \dots, W_k , such that:

1. for each $i \in [k]$ the set U_i is a segment of $[a]$ and the set W_i is a segment of $[b]$,
2. for each distinct $i, j \in [k]$ we have $U_i \cap U_j = \emptyset$ and $W_i \cap W_j = \emptyset$,
3. for every $i \in [k]$, the average degree of the graph $G[U_i \cup W_i]$ is at least r .

The Dense Case. In this section, we prove Theorem 4 roughly in the case when there are two linkages \mathcal{L} and \mathcal{K} such that their set $A(\mathcal{L}) \cup A(\mathcal{K}) \cup B(\mathcal{L}) \cup B(\mathcal{K})$ of endpoints is well linked and such that the paths in \mathcal{L} and \mathcal{K} intersect a lot. The formal statement proved in this section is as follows.

Lemma 10 Let $a, b \in \mathbb{N}^+$. Let D be a directed graph and \mathcal{L} and \mathcal{K} be two linkages in D such that $A(\mathcal{L}) \cup B(\mathcal{L}) \cup A(\mathcal{K}) \cup B(\mathcal{K})$ is well-linked in D . Suppose that the intersection graph $I(\mathcal{L}, \mathcal{K})$ has degeneracy more than $384000 \cdot a \cdot b \cdot \log_2(|\mathcal{L}|/b)$. Then there are directed graphs D_1, D_2, \dots, D_a with the following properties:

- (i) each D_i is a subgraph of D ,
- (ii) each vertex of D belongs to at most four graphs D_i , and
- (iii) each graph D_i has directed treewidth at least b .

Proof Outline. The basic idea of the proof of Lemma 10 is as follows. We first fix a pair of linkages $\mathcal{L}^{\text{back}}$ and $\mathcal{K}^{\text{back}}$ which are dual to \mathcal{L} and \mathcal{K} , respectively. (This is possible because of well-linkedness of the endpoints.) The subgraphs D_i that we construct will subpartition the vertex set of each of the four linkages $\mathcal{L}, \mathcal{L}^{\text{back}}, \mathcal{K}, \mathcal{K}^{\text{back}}$ and hence each vertex of G is in at most four subgraphs D_i . we apply the partitioning lemma (Lemma 9) to the intersection graph of \mathcal{L} and \mathcal{K} , obtaining a subpartition I_1, \dots, I_k of \mathcal{L} and a subpartition J_1, \dots, J_k of \mathcal{K} . These subpartitions have the nice property that each intersection graph $I(I_i, J_i)$ induced by a pair I_i, J_i contains many edges (representing intersections between the corresponding paths) and that only a constant number of cycles of $\text{Aux}(\mathcal{L})$ and $\text{Aux}(\mathcal{K})$ cross I_i or J_i . By closing each of these crossing cycles by introducing an artificial new path, we obtain a pair of dual linkages I_i, I'_i , and a pair of dual of linkages J_i, J'_i . Using then Lemma 11 below, we will obtain a lower bound on the directed treewidth of the graph induced by $I_i \cup J_i \cup I'_i \cup J'_i$, which constitute our desired subgraph D_i .

Lemma 11² Let $k, d \in \mathbb{N}^+$ and $\mathcal{P}, \mathcal{P}^{\text{back}}, \mathcal{Q}, \mathcal{Q}^{\text{back}}$ be four half-integral linkages in a directed graph such that \mathcal{P} and $\mathcal{P}^{\text{back}}$ are dual to each other and \mathcal{Q} and $\mathcal{Q}^{\text{back}}$ are dual to each other. Let the intersection graph $I(\mathcal{P}, \mathcal{Q})$ have minimum degree at least d where $d \geq 8k \log_{\frac{4}{3}}(\frac{|\mathcal{P}|}{24k}) + 24k + 4$. Then the graph $\bigcup(\mathcal{P} \cup \mathcal{P}^{\text{back}} \cup \mathcal{Q} \cup \mathcal{Q}^{\text{back}})$ has directed treewidth at least k .

Proof of Theorem 4. Let G be a directed graph of $\text{dtw}(G) \geq c \cdot a^6 b^8 \log^2(ab)$, where c is a large constant, whose value will follow from the reasoning below. First, we invoke Lemma 6 with $\beta = 2^{37} a^2 b^3 \log(ab)$ and $\alpha = 8ab$ (here we assume that c is sufficiently large so that the assumption is satisfied). We obtain a set of vertex-disjoint paths P_1, \dots, P_{8ab} and sets $A_i, B_i \subseteq V(P_i)$, where A_i appears before B_i on P_i , and $|A_i| = |B_i| = 2^{37} a^2 b^3 \log(ab)$, and the set $\bigcup_{i=1}^{8ab} A_i \cup B_i$ is well-linked. Denote by $\mathcal{L}_{i,j}$ a linkage from B_i to A_j .

We split the $8ab$ paths P_i into a segments, each consisting of $8b$ paths. Formally, for every $\iota \in [a]$ we define $I_\iota = \{j \mid 8(\iota - 1)b < j \leq 8\iota b\}$.

²The proof of Lemma 11 is inspired by the proof of Lemma 5.4 in [4]. We could use Lemma 5.4 here as well, but its proof, unfortunately, contains errors. Nevertheless, we derive an incomparable bound which is much better for our use since the lower bound claimed in Lemma 5.4 [4] is k^2 .

Now we set $r = 64ab^2$ and create an auxiliary r -colored graph H , whose vertices will be paths of appropriately chosen linkages $\mathcal{L}_{i,j}$. More specifically, for every $\iota \in [a]$, and every $i, j \in I_\iota$, we introduce a vertex for every path in $\mathcal{L}_{i,j}$ and color it (i, j) . Two vertices of H are adjacent if and only if their corresponding paths share a vertex in G . Note that for two linkages $\mathcal{L}_{i,j}$ and $\mathcal{L}_{i',j'}$, the graph $H[\mathcal{L}_{i,j} \cup \mathcal{L}_{i',j'}]$ is precisely the intersection graph $I(\mathcal{L}_{i,j}, \mathcal{L}_{i',j'})$.

We set $d := 2^{27}ab \log(ab)$ and consider two cases:

- (i) for all i, j, i', j' the graph $I(\mathcal{L}_{i,j}, \mathcal{L}_{i',j'})$ is d -degenerate.
- (ii) there exist i, j, i', j' , for which the graph $I(\mathcal{L}_{i,j}, \mathcal{L}_{i',j'})$ is not d -degenerate.

An intuition behind case (i) is that for each subgraph of H there is always a path (in G) such that it shares a vertex with at most d paths from all used linkages back.

Case (i) We use Lemma 7 on H . Graph H has $64ab^2$ color classes such that for each $(i, j) \neq (i', j')$ the graph $H[\mathcal{L}_{i,j} \cup \mathcal{L}_{i',j'}]$ is d -degenerate. Note that $|\mathcal{L}_{i,j}| = 2^{37}a^2b^3 \log(ab) \geq 4e(r-1)d$ is sufficiently large to satisfy the last assumption of the lemma. We are given an independent set x_1, \dots, x_{64ab^2} that represents pairwise disjoint paths $L_{i,j}$ from B_i to A_j for all $i, j \in I_\iota$. We also recall that A_i and B_i lie on P_i and all P_i 's are pairwise disjoint.

Let G_ι consist of all paths P_i for $i \in I_\iota$ and $L_{i,j}$ for $i, j \in I_\iota$. By Lemma 8 for $k = 8b$ we obtain $\text{dtw}(G_\iota) \geq b$ while each vertex is in at most 2 such subgraphs. Indeed, each vertex can appear only once on some P_i and once on some $L_{i,j}$.

Case (ii) The claim follows from Lemma 10. Since $|\mathcal{L}| = 2^{37}a^2b^3 \log(ab)$ then $d = 2^{27}ab \log(ab) > 2^{19}ab \log(2^{37}a^2b^2 \log(ab))$.

References

- [1] S. A. Amiri, K. Kawarabayashi, S. Kreutzer, and P. Wollan. The Erdős-Pósa property for directed graphs. *CoRR*, abs/1603.02504, 2016.
- [2] C. Chekuri and J. Chuzhoy. Large-treewidth graph decompositions and applications. In *Proceedings of the 45th Annual ACM Symposium on Theory of Computing (STOC 2013)*, pages 291–300. ACM, 2013.
- [3] P. Erdős and L. Pósa. On independent circuits contained in a graph. *Canadian Journal of Mathematics*, 17:347–352, 1965.
- [4] M. Hatzel, K. Kawarabayashi, and S. Kreutzer. Polynomial planar directed grid theorem. In *Proceedings of the 30th Annual ACM-SIAM Symposium on Discrete Algorithms (SODA 2019)*, pages 1465–1484, 2019.
- [5] K. Kawarabayashi and S. Kreutzer. The directed grid theorem. In *Proceedings of the 47th Annual ACM Symposium on Theory of Computing (STOC 2015)*, pages 655–664, 2015.
- [6] T. Masařík, I. Muzi, M. Pilipczuk, P. Rzażewski, M. Sorge. Packing directed circuits quarter-integrally. In *Proceedings of the 27th Annual European Symposium on Algorithms (ESA 2019)*, pages 72:1–72:13, 2019.
- [7] B. Reed. Introducing directed tree width. *Electronic Notes in Discrete Mathematics*, 3:222–229, 1999.
- [8] B. Reed, N. Robertson, P. D. Seymour, and R. Thomas. Packing directed circuits. *Combinatorica*, 16(4):535–554, 1996.
- [9] B. A. Reed and D. R. Wood. Polynomial treewidth forces a large grid-like-minor. *European Journal of Combinatorics*, 33(3):374–379, 2012.

On the Circumference of 3-Connected Maximal 1-Planar Graphs¹

Samuel Mohr

Technische Universität Ilmenau, Germany

Abstract

Chen and Yu verified a conjecture of Moon and Moser that there is a positive constant c such that the length of a longest cycle of each 3-connected planar graph G is at least $c \cdot |V(G)|^{\log_3 2}$.

A graph is 1-planar if it has a drawing in the plane such that each edge is crossed at most once by another edge and it is maximal 1-planar if it is 1-planar and no edge between non-adjacent vertices can be added to keep its 1-planarity. We will confirm the results of Moon and Moser and Chen and Yu for the class of maximal 1-planar that a longest cycle of 3-connected maximal 1-planar is at least $c \cdot |V(G)|^{\log_3 2}$ and this bound is asymptotically optimal.

Keywords: 1-planar graph, spanning subgraph, longest cycle, circumference, hamiltonicity.

Extended Abstract

We use standard terminology of graph theory and consider finite and simple graphs, where $V(G)$ and $E(G)$ denote the vertex set and the edge set of a graph G , respectively. These graphs are represented by *drawings* in the plane, such that vertices are distinct points and edges are arcs, i. e. non-self-intersecting continuous curves.

A graph G is *planar* if there exists a drawing of G such that two arcs only meet at end vertices. There are several approaches to generalize the concept of planarity. One of them is to allow a given constant number of crossings for each edge in a drawing. It is easy to see that a drawing can be changed locally to a different drawing with fewer crossings if two edges with a shared end vertex cross or if two edges cross several times. Thus, in the sequel we will consider drawings with the property that if two edges cross, then they do so exactly once and their four end vertices are mutually distinct.

If there exists a drawing of a graph G such that each edge is crossed at most once by another edge, then G is *1-planar*. This class of graphs was introduced by Ringel [9] in connection with the simultaneous vertex-face colouring of plane graphs. Properties of 1-planar graphs are widely studied and can be found for example in [4, 5, 6, 8].

A graph G from a family \mathcal{G} of graphs is *maximal* if $G + uv \notin \mathcal{G}$ for any two non-adjacent vertices $u, v \in V(G)$. In this sense, a graph is maximal 1-planar if it is 1-planar but each $G + uv$ for non-adjacent vertices $u, v \in V(G)$ is not.

The length (number of vertices) of a longest cycle of a graph G (also called *circumference* of G) is denoted by $\text{circ}(G)$. If $\text{circ}(G) = n$ for a graph G on n vertices, then G is *hamiltonian* and a longest cycle of G is a *hamiltonian cycle*.

In 1931, Whitney [10] proved that each 4-connected maximal planar graph is hamiltonian. However, in the 3-connected case, Moon and Moser [7] constructed infinitely many maximal planar graphs G with $\text{circ}(G) \leq 9|V(G)|^{\log_3 2}$. Furthermore, it is conjectured in [7] that there is a constant c such that each 3-connected planar graph G has $\text{circ}(G) \geq c \cdot |V(G)|^{\log_3 2}$. This was proved later by Chen and Yu [2].

We are interested in the circumference of 3-connected maximal 1-planar graphs. In [4], the question remained open whether every maximal 1-planar graph is hamiltonian. Moreover, the question arises whether such a construction as the one of Moon and Moser is also possible in the class of 3-connected maximal 1-planar graphs.

¹joint work with I. Fabrici, J. Harant, T. Madaras, R. Soták, and C. Zamfirescu supported by DAAD, Germany (as part of BMBF) and the Ministry of Education, Science, Research and Sport of the Slovak Republic within the project 57447800.

An affirmative answer to both questions is given by Theorem 1:

Theorem 1

(i) If H is a maximal planar graph on $n \geq 3$ vertices, then there is a 3-connected maximal 1-planar graph G on $7n - 12$ vertices such that $\text{circ}(G) \leq 4 \cdot \text{circ}(H)$.

(ii) Each 3-connected maximal 1-planar graph has a spanning 3-connected planar subgraph.

Given a 3-connected maximal planar graph H with $\text{circ}(H) \leq 9|V(H)|^{\log_3 2}$, e.g. these graphs constructed by Moon and Moser in [7]. For the graph G obtained from H in Theorem 1 (i), $\text{circ}(G) \leq c' \cdot |V(G)|^{\log_3 2}$ for a suitable constant c' holds. Hence, the circumference of these graphs is still sublinear in the same magnitude.

On the other hand, let G be a 3-connected maximal 1-planar graph on n vertices and H be a planar 3-connected spanning subgraph which is guaranteed by Theorem 1 (ii). Using Chen and Yu's result, H has a cycle of order at least $c \cdot n^{\log_3 2}$. But this is also a cycle of G and immediately Corollary 2 follows:

Corollary 2 *There are positive constants c and c' such that each 3-connected maximal 1-planar graph G has $\text{circ}(G) \geq c \cdot |V(G)|^{\log_3 2}$ and an infinitely family of maximal 1-planar graphs G with circumference $\text{circ}(G) \leq c' \cdot |V(G)|^{\log_3 2}$ exists.*

We showed how to extend the result of Chen and Yu to 3-connected maximal 1-planar graphs. In the same vein, using Theorem 1 (ii), the result of Barnette [1] that a 3-connected planar graph has a spanning tree of maximum degree at most 3, the result of Gao [3] that a 3-connected planar graph has a spanning 2-connected subgraph of maximum degree at most 6, and any other result concerning the existence of a certain subgraph of a planar 3-connected graph can easily be extended to the class of 3-connected maximal 1-planar graphs.

References

- [1] D.W. Barnette, Trees in polyhedral graphs, *Canad. J. Math.* 18(1966)731–736.
- [2] G. Chen and X. Yu, Long cycles in 3-connected graphs, *J. Combin. Theory, Ser. B* 86(2002)80–99.
- [3] Z. Gao, 2-connected coverings of bounded degree in 3-connected graphs, *J. Graph Theory* 20(1995)327–338.
- [4] D. Hudák, T. Madaras, and Y. Suzuki, On properties of maximal 1-planar graphs, *Discuss. Math. Graph Theory* 32(2012)737–747.
- [5] V.P. Korzhik, Minimal non-1-planar graphs, *Discrete Math.* 308(2008)1319–1327.
- [6] V.P. Korzhik and B. Mohar, Minimal obstructions for 1-immersions and hardness of 1-planarity testing, *J. Graph Theory* 72(2013)30–71.
- [7] J.W. Moon and L. Moser, Simple paths on polyhedra, *Pacific J. Math.* 13(1963)629–631.
- [8] J. Pach and G. Tóth, Graphs drawn with few crossings per edge, *Combinatorica* 17(1997)427–439.
- [9] G. Ringel, Ein Sechsfarbenproblem auf der Kugel, *Abh. Math. Sem. Univ. Hamburg* 29(1965)107–117.
- [10] H. Whitney, A Theorem on Graphs, *Ann. Math.* 32(1931)378–390.

A new lower bound of the number of contractible edges on longest cycles in a 3-connected graph

Shunsuke Nakamura

Department of Mathematics, Tokyo University of Science
1-3 Kagurazaka, Shinjuku-ku, Tokyo 162-8601, Japan

EXTENDED ABSTRACT

1 Introduction

In this paper, we consider only finite, simple, undirected graphs with no loops and no multiple edges.

Let $G = (V(G), E(G))$ be a graph. A graph G is called *3-connected* if $|V(G)| \geq 4$ and $G - S$ is connected for any subset S of $V(G)$ having cardinality 2. Let G be a 3-connected graph. An edge e of G ($|V(G)| \geq 5$) is called *contractible* if the graph which we obtain from G by contracting e into one vertex (and replacing each of the resulting pairs of parallel edges by a simple edge) is 3-connected; otherwise e is called *noncontractible*. We let $E_c(G)$ denote the set of contractible edges of G and $E_{nc}(G)$ denote the set of noncontractible edges of G ; thus $E(G) = E_c(G) \cup E_{nc}(G)$ (disjoint union).

In [11], Tutte proved that if G is a 3-connected graph other than K_4 , then $E_c(G) \neq \emptyset$. In [2], Dean, Hemminger and Ota proved that if G is a 3-connected graph other than K_4 or $K_2 \times K_3$, then every longest cycle C of G satisfies $|E(C) \cap E_c(G)| \geq 3$. In [3], Ellingham, Hemminger and Johnson proved that if G is a nonhamiltonian 3-connected graph, then every longest cycle C of G satisfies $|E(C) \cap E_c(G)| \geq 6$. Further the classification of those pairs (G, C) of a 3-connected graph G and a longest cycle C of G such that $3 \leq |E(C) \cap E_c(G)| \leq 5$ (then C is hamiltonian) has been completed by [1, 4, 5, 9] and [10]. On the other hand, in [10], Ota made a conjecture that there exists a constant $\alpha > 0$ such that if G is a 3-connected graph of order at least 5, then G has a longest cycle C such that $|E(C) \cap E_c(G)| \geq \alpha|E(C)|$. In [4] and [7], Fujita proved that such a constant exists if we restrict ourselves to 3-connected graph.

Theorem A *Let G be a 3-connected hamiltonian graph of order at least 5. Then there exists a hamiltonian cycle C of G such that $|E(C) \cap E_c(G)| \geq \lceil \frac{1}{8}|E(C)| + \frac{9}{8} \rceil$.*

Further in [8], we showed that the same conclusion holds for 3-connected graphs in general.

Theorem B *Let G be a 3-connected graph of order at least 5. Then there exists a longest cycle C of G such that $|E(C) \cap E_c(G)| \geq \lceil \frac{1}{8}|E(C)| + \frac{9}{8} \rceil$.*

Furthermore, in [6], Fujita proved the following theorem which is a refinement of Theorem B.

Theorem C *Let G be a 3-connected graph of order at least 5. Then there exists a longest cycle C of G such that $|E(C) \cap E_c(G)| \geq \lceil \frac{1}{7}|E(C)| + 1 \rceil$.*

In this talk, we introduce the following theorem, which is a refinement of Theorem C.

Theorem 1 *Let G be a 3-connected graph of order at least 5. Then there exists a longest cycle C of G such that $|E(C) \cap E_c(G)| \geq \lceil \frac{1}{6}|E(C)| + \frac{5}{6} \rceil$.*

Let α_0 denote the supremum of those real numbers α which make true the aforementioned conjecture of Ota. Theorem C shows $\alpha_0 \geq \frac{1}{7}$, and we obtain $\alpha_0 \geq \frac{1}{6}$. On the other hand, $\alpha_0 \leq \frac{1}{3}$. To see this, let G be the line graph of a graph obtained from a 3-regular 3-connected graph by subdividing all edges once. Then G is 3-connected, and $|E(C) \cap E_c(G)| = \frac{|E(C)|}{3}$ for every longest cycle C of G . Thus we make a conjecture as follows.

Conjecture 2 *Let G be a 3-connected graph of order at least 5. Then there exists a longest cycle C of G such that $|E(C) \cap E_c(G)| \geq \lceil \frac{1}{3}|E(C)| \rceil$.*

Our notation and terminology are standard except possibly for the following. Let G be a graph. A subset S of $V(G)$ is called a *cutset* if $G - S$ is disconnected; thus G is 3-connected if and only if $|V(G)| \geq 4$ and G has no cutset of cardinality 2. If G is 3-connected, then for $e = uv \in E(G)$, we let $K(e) = K(u, v)$ denote the set of vertices x of G such that $\{u, v, x\}$ is a cutset; thus e is contractible if and only if $K(e) = \emptyset$. If $e = uv$ is noncontractible, then for each $x \in K(e)$, $\{u, v, x\}$ is called a *cutset associated with e* .

2 Statement of Propositions

Let G be a 3-connected graph of order at least 5, and let C be a longest cycle of G such that no longest cycle has more contractible edges than C . i.e.,

$$\text{there is no longest cycle } C' \text{ of } G \text{ such that } |E(C') \cap E_c(G)| > |E(C) \cap E_c(G)|. \quad (2.1)$$

If $E(C) \cap E_{nc}(G) = \emptyset$, then $E(C) \cap E_c(G) = E(C)$, and hence then Theorem 1 trivially holds. Thus we may assume that $E(C) \cap E_{nc}(G) \neq \emptyset$. Write

$$C = v_0 v_1 \cdots v_n v_0, \text{ where } n \geq 4.$$

Without loss of generality, we may assume that $v_n v_0 \in E_{nc}(G)$. Let $\{v_n, v_0, v_k\}$ be a cutset associated with it. Set

$$P_1 = v_n v_0 v_1 \cdots v_k \text{ and } P_2 = v_k v_{k+1} \cdots v_n v_0.$$

Then $|E(P_1)| + |E(P_2)| = |E(C)| + 1$, and $|E(P_1) \cap E_c(G)| + |E(P_2) \cap E_c(G)| = |E(C) \cap E_c(G)|$ since $v_n v_0 \in E_{nc}(G)$. Thus to prove Theorem 1, it suffices to prove the following proposition.

Proposition 2.1 $|E(P_1) \cap E_c(G)| \geq \frac{1}{6}|E(P_1)| + \frac{1}{3}$ and $|E(P_2) \cap E_c(G)| \geq \frac{1}{6}|E(P_2)| + \frac{1}{3}$.

Now, we define the following set \mathcal{F} .

Definition 2.2 $\mathcal{F} = \{P \subsetneq C \mid \text{there exist } x, y, z \in V(G) \text{ such that } P \text{ is an } x\text{-}z\text{ path, } xy \in E(P) \text{ and } z \in K(x, y)\}$.

Note that $v_i v_{i+1} \cdots v_j \in \mathcal{F}$ if and only if $v_j \in K(v_i, v_{i+1})$ or $v_i \in K(v_{j-1}, v_j)$ (indices are to be read modulo $n + 1$).

Note also that $P_1 \in \mathcal{F}$ and $P_2 \in \mathcal{F}$ because $v_k \in K(v_n, v_0)$. Hence Proposition 2.1 follows from the following proposition.

Proposition 2.3 *Let $W \in \mathcal{F}$. Then $|E(W) \cap E_c(G)| \geq \frac{1}{6}|E(W)| + \frac{1}{3}$.*

Now, we define Type L as a name of special paths on C .

Definition 2.4 *Set $A = v_i v_{i+1} \cdots v_j$ (indices are to be read modulo $n + 1$). A is said to be of Type L if and only if $j = i + 4$ (so $|E(A)| = 4$ and $A = v_i v_{i+1} v_{i+2} v_{i+3} v_{i+4}$) and one of the following holds:*

- (i) $v_{i+4} \in K(v_i, v_{i+1})$ and $v_{i+2} v_{i+3} \in E_{nc}(G)$; or
- (ii) $v_i \in K(v_{i+3}, v_{i+4})$ and $v_{i+1} v_{i+2} \in E_{nc}(G)$.

The following two lemmas appear as Lemmas 3.1 and 3.2, respectively, in [6].

Lemma 2.5 *If A is of Type L , then $A \in \mathcal{F}$.*

Lemma 2.6 *If A is of Type L, then $|E(A) \cap E_c(G)| \geq 1$.*

Having Lemmas 2.5 and 2.6 in mind, in order to prove Proposition 2.3, it suffices to prove the following proposition.

Proposition 2.7 *Let $W \in \mathcal{F}$ such that W is not of Type L. Then $|E(W) \cap E_c(G)| \geq \frac{1}{6}|E(W)| + \frac{1}{2}$.*

We conclude this section with the following lemma which appears as Lemma 3.3 in [6].

Lemma 2.8 *Let $A \in \mathcal{F}$. Then $|E(A)| \geq 1$. Further if $|E(A)| = 3$, then $|E(A) \cap E_c(G)| \geq 1$.*

3 Admissible partition

In [7], an *admissible partition* is defined under the condition that G is a 3-connected hamiltonian graph. But even if G is nonhamiltonian, an *admissible partition* can be defined in the identical way. In this section, we define an *admissible partition* for a 3-connected graph in general.

As in the preceding section, let G be a 3-connected graph of order at least 5, let C be a longest cycle of G satisfying (2.1), and write $C = v_0v_1 \cdots v_nv_0$. Assume that $E(C) \cap E_{nc}(G) \neq \emptyset$, and let \mathcal{F} be as in Definition 2.2. The following lemma appears as Lemma 4.29 in [7].

Lemma 3.1 *Let $P \in \mathcal{F}$, and write $P = v_iv_{i+1} \cdots v_j$ (indices are to be read modulo $n+1$). Then there exists*

$$\mathcal{B} = \{A_1, A_2, \dots, A_t\}$$

such that

$$E(P) - \{v_iv_{i+1}\} = \bigcup_{h=1}^t E(A_h) \text{ (disjoint union)}$$

or

$$E(P) - \{v_{j-1}v_j\} = \bigcup_{h=1}^t E(A_h) \text{ (disjoint union)}$$

according as $v_j \in K(v_i, v_{i+1})$ or $v_i \in K(v_{j-1}, v_j)$,

$$|E(P) \cap E_c(G)| = \sum_{h=1}^t |E(A_h) \cap E_c(G)|,$$

and for each $1 \leq h \leq t$, one of the following holds:

- (i) $A_h \in \mathcal{F}$ (so $|E(A_h)| \geq 3$);
- (ii) $A_h \notin \mathcal{F}$, $|E(A_h)| = 5$ and $|E(A_h) \cap E_c(G)| \geq 2$;
- (iii) $|E(A_h)| = 2$ and $|E(A_h) \cap E_c(G)| \geq 1$; or
- (iv) $|E(A_h)| = |E(A_h) \cap E_c(G)| = 1$.

Having Lemma 3.1 in mind, an *admissible partition* can be defined as in the same way as in Definition 4.5 of [7].

Definition 3.2 (an admissible partition) *For $P \in \mathcal{F}$, a family $\mathcal{B} = \{A_1, A_2, \dots, A_t\}$ of paths satisfying the conditions stated in Lemma 3.1 is called an *admissible partition* of P . For $A_h \in \mathcal{B}$, A_h is said to be of Type R, Type F, Type S, or Type T according as A_h satisfies (i), (ii), (iii), or (iv) of Lemma 3.1.*

4 An outline of the proof of Proposition 2.7

We prove Proposition 2.7 by induction on $|E(W)|$. By Lemma 2.8, $|E(W)| \geq 3$. If $|E(W)| = 3$, then $|E(W) \cap E_c(G)| \geq 1$ by Lemma 2.8, and hence $|E(W) \cap E_c(G)| \geq \frac{1}{6}|E(W)| + \frac{1}{2}$, as desired. Thus let $|E(W)| = w \geq 4$, and assume that $|E(P) \cap E_c(G)| \geq \frac{1}{6}|E(P)| + \frac{1}{2}$ for any $P \in \mathcal{F}$ such that P is not of Type L and $|E(P)| \leq w - 1$.

Further by way of contradiction, suppose that $|E(W) \cap E_c(G)| < \frac{1}{6}|E(W)| + \frac{1}{2}$. Then we obtain the following claim.

Claim 4.1 *Let Q be a member of \mathcal{F} such that $Q \subseteq W$ and $|E(Q)| \geq 4$, and let \mathcal{B} be an admissible partition of Q . Then, if $|E(W)| - |E(Q)| \leq 1$, the following (i) occurs, if $|E(W)| - |E(Q)| = 2$, the following (i) or (ii) occurs, and if $|E(W)| - |E(Q)| = 3$, the following (i), (ii) or (iii) occurs.*

- (i) $|\mathcal{B}| = 1$, and if we write $\mathcal{B} = \{B\}$, then we have $|E(Q)| - |E(B)| = 1$ and $B \in \mathcal{F}$.
- (ii) $|\mathcal{B}| = 2$, and if we write $\mathcal{B} = \{B_1, B_2\}$, then $B_1, B_2 \in \mathcal{F}$ and either B_1 or B_2 is of Type L.
- (iii) $|\mathcal{B}| = 2$, and if we write $\mathcal{B} = \{B_1, B_2\}$, then $B_1, B_2 \in \mathcal{F}$ and both B_1 and B_2 are not of Type L.

We prove Proposition 2.7 by using Claim 4.1 and finding the cycle C' which satisfies either $|E(C')| = |E(C)|$ and $|E(C') \cap E_c(G)| > |E(C) \cap E_c(G)|$ or $|E(C')| > |E(C)|$ since this contradicts (2.1) or the maximality of the length of C , respectively.

References

- [1] R. E. L. Aldred, R. L. Hemminger and K. Ota, The 3-connected graphs having a longest cycle containing only three contractible edge, *J. Graph Theory* **17** (1993), 361–371.
- [2] N. Dean, R. L. Hemminger and K. Ota, Longest cycles in 3-connected graphs contain three contractible edges, *J. Graph Theory* **12** (1989), 17–21.
- [3] M. N. Ellingham, R. L. Hemminger and K. E. Johnson, Contractible edges in longest cycles in nonhamiltonian graphs, *Discrete Math.* **133** (1994), 89–98.
- [4] K. Fujita, Contractible edges on hamiltonian cycles of 3-connected graphs, *Ph. D. Dissertation, Sience University of Tokyo* (2001).
- [5] K. Fujita, Longest cycles C in a 3-connected graph G such that C contains precisely four contractible edges of G , *Math. Japonica* **43** (1996), 99–116.
- [6] K. Fujita, Lower bounds on the maximum number of contractible edges on longest cycles of a 3-connected graph, *Far East J. Appl. Math.* **22** (2006), 55–86.
- [7] K. Fujita, Maximum number of contractible edges on hamiltonian cycles of a 3-connected graph, *Graphs Combin.* **18** (2002), 447–478.
- [8] K. Fujita, Maximum number of contractible edges on longest cycles of a 3-connected graph, *Ars Combin.* **74** (2005), 129–149.
- [9] K. Fujita and K. Kotani, Classification of hamiltonian cycles of a 3-connected graph which contain five contractible edges, *SUT J. Math.* **36** (2000), 287–350.
- [10] K. Ota, Non-critical subgraphs in k -connected graphs, *PH. D. Dissertation, University of Tokyo* (1989).
- [11] W. T. Tutte, A theory of 3-connected graphs, *Indag. Math.* **23** (1961), 441–445.

Signed graphs with bicircular matroids

Konstantinos Papalamprou

Department of Electrical and Computer Engineering
Aristotle University of Thessaloniki, Thessaloniki, Greece

EXTENDED ABSTRACT

1 Introduction

In a recent work, [6], Sivaraman gave a characterization of graphs whose bicircular matroids are signed-graphic and in that way he extended a result of Matthews in [2] who characterized graphs whose bicircular matroids are graphic. In the same work, Sivaraman stated, among other interesting open research issues, the following question: "Characterize signed graphs whose matroids are bicircular". Towards answering this question, we identify classes of signed graphs whose frame matroids (i.e. signed-graphic matroids) are bicircular.

We assume that the reader is familiar with basic notions of matroid theory and signed graphs as provided in [3] and [8], respectively. In the next section, we provide some preliminaries regarding signed-graphic matroids and bicircular matroids while in the Section 3 we present the results. Finally, at the last section we state interesting problems related directly to the question of Sivaraman mentioned in the preceding paragraph.

2 Preliminaries

The class of bicircular matroid was introduced in [2] and is defined on the edge set of graph. Specifically, given a graph G the circuits of the bicircular matroid of G , denoted by $B(G)$, are the edge sets of subgraphs of G being a subdivision of one of the graphs of Figure 2.

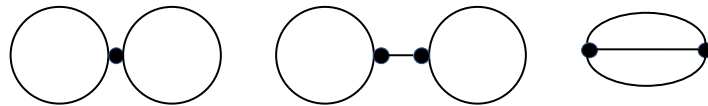

Figure 1: Circuits in a bicircular matroid.

Signed-graphic matroids were introduced by Zaslavsky in [8] and are defined on the edge set of a signed graph. A signed graph can be viewed as group-labeled graph where each edge (link or loop) is labeled as either positive or negative. Given a signed graph Σ , the graph obtained by Σ if we ignore the signs on its edges is called the underlying graph of Σ . A cycle of a signed graph is said to be negative if it contains an odd number of negative edges; otherwise, it is a positive cycle. The signed-graphic matroid of a signed graph Σ , denoted by $M(\Sigma)$, has as a circuit the edge set of a subgraph of Σ which is either: (a) a positive cycle or (b) two negative cycles which have exactly one common vertex, or (c) two vertex-disjoint negative cycles connected by a path which has no common vertex with the cycles apart from its end-vertices. Examples of such circuits are given in Figure 2, where dashed lines depict negative edges while solid lines depict positive edges.

3 Classes of signed graphs with bicircular matroids

In the following result, we utilize the circuit-based definitions of bicircular matroids and signed-graphic matroids, given in the preceding section, in order to identify a class of signed graphs whose frame matroids are bicircular.

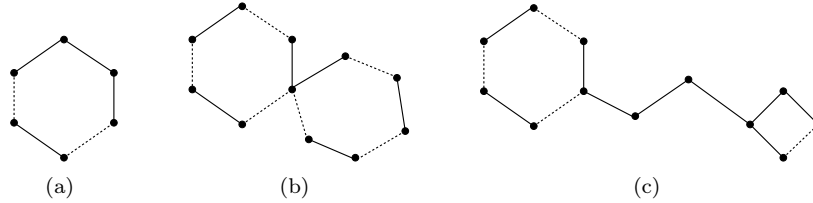

Figure 2: Example circuits in a signed-graphic matroid.

Theorem 1 *If each component of a signed graph Σ can be obtained from a subdivision of a tree by replacing each edge of the tree by a negative cycle or a link (positive or negative) and attaching at each node any number of negative loops, then $M(\Sigma)$ is bicircular.*

Proof: Let G be the underlying graph of Σ ; we shall show that $M(\Sigma) = B(G)$. Since the ground sets of $M(\Sigma)$ and $B(G)$ coincide, it remains to show that each circuit of $M(\Sigma)$ is a circuit of $B(G)$ and vice versa. By the way Σ has been constructed there is no circuit of $B(G)$ corresponding to a subgraph of G which is a subdivision of a theta graph (third graph in Figure 2). Thus, all circuits of $B(G)$ are edge sets of subgraphs of G which are either two cycles which have exactly one common vertex or two vertex-disjoint negative cycles connected by a path which has no common vertex with the cycles apart from its end-vertices. Given the fact that by construction all cycles are negative we have that each of these edge sets in Σ correspond to a circuit of $M(\Sigma)$. Finally, by construction Σ has no positive cycles; therefore each circuit of $M(\Sigma)$ corresponds to an edge set which induces a graph of type (b) or (c) of Figure 2 and therefore, it corresponds to a circuit of $B(G)$. \square

In the next result we restrict ourselves to balanced signed graphs, i.e. signed graphs having no negative cycles. Taking into account that the signed-graphic matroids of balanced signed graphs are graphic, the following result may be viewed as a direct consequence of Matthews characterization of graphs whose bicircular matroids are graphic given in [2].

Theorem 2 *Let Σ be a balanced signed graph. Then $M(\Sigma)$ is bicircular if and only if Σ has no subgraph homeomorphic to any of the signed graphs of Figure 3, where all cycles are positive and a graph with a dotted edge represents either the graph itself or the graph obtained when the dotted edge is contracted.*

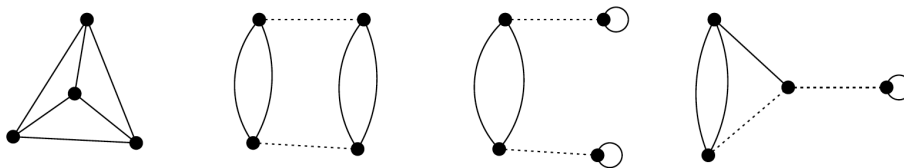

Figure 3: Forbidden balanced signed graphs.

4 Related problems

The problem under consideration, i.e. the characterization of signed graphs whose matroids are bicircular, could be relaxed if we consider only the case of tangled signed graphs, where a tangled signed graph is a signed graph with no two vertex-disjoint negative cycles. As known (see e.g. [7]), tangled signed graphs represent binary signed-graphic matroids and

thus, in that way, we could restrict ourselves on signed-graphical representations of bicircular matroids which fall into the class of binary matroids. Finally, the recognition problem of bicircular matroids remains open (a progress has been made in [1]); we believe that having a way to obtain signed-graphical representations for a class of bicircular matroids and utilizing the results of [4, 5] may be of critical importance on devising a polynomial time algorithm that would recognize whether a given a matroid belongs or not to the class of signed-graphic bicircular matroids.

References

- [1] C.R. Coullard and J.G. Del Greco, D.K. Wagner. Recognizing a class of bicircular matroids. **Discrete Appl. Math.**, 43:197–215, 1993.
- [2] L.R. Matthews. Bicircular matroids. In **Q. J. Math.**, 28:213–227, 1977.
- [3] J.G. Oxley. Matroid Theory. Oxford University Press, 2011.
- [4] K. Papalamprou and L. Pitsoulis. Recognition algorithms for binary signed-graphic matroids. In **Lecture Notes in Comput. Sci.**, 74:463–473, 2012.
- [5] K. Papalamprou and L. Pitsoulis. Decomposition of binary signed-graphic matroids. In **SIAM J. Discrete Math.**, 27:669–692, 2013.
- [6] V. Sivaraman. Bicircular signed-graphic matroids. In **Discrete Math.**, 328:1–4, 2014.
- [7] D. Slilaty, H. Qin. Decompositions of signed-graphic matroids. In **Discrete Math.**, 307:2187–2199, 2007.
- [8] T. Zaslavsky. Signed graphs. In **Discrete Appl. Math.**, 4:47–74, 1982.

A Brooks-like result for graph powers

Théo Pierron

Univ. Bordeaux, Bordeaux INP, CNRS, LaBRI, UMR5800, F-33400 Talence, France
Faculty of Informatics Masaryk University, Brno, Czech Republic
This work was supported by the ANR project HOSIGRA (ANR-17-CE40-0022).

EXTENDED ABSTRACT

1 Introduction

Coloring a graph G consists in finding an assignment of colors $c : V(G) \rightarrow \{1, \dots, p\}$ such that any pair of adjacent vertices receive different colors. The minimum integer p such that a coloring exists is called the chromatic number of G , denoted by $\chi(G)$. We denote by $\Delta(G)$ the maximum degree of the graph G . Note that regarding coloring, we may only consider connected graphs. Using a greedy algorithm, it is easy to show that every graph G can be colored with $\Delta(G) + 1$ colors. A seminal result from Brooks characterizes the cases when this bound is tight:

Theorem 1 ([2]). *For every graph G , $\chi(G) \leq \Delta(G)$ excepted if $G = K_{\Delta(G)+1}$ or $\Delta = 2$ and G is an odd cycle.*

Given an integer $k \geq 1$ and a graph G , the k -th power of G is the graph obtained from G by adding an edge between vertices at distance at most k in G . We are interested in coloring such powers of graphs. First note that coloring powers of paths and cycles is settled by the following result, hence we may only consider graphs with maximum degree at least 3. In particular, none of the graphs we consider below is a cycle.

Proposition 2 ([6]). *Let n, k be two integers. Then*

- $\chi(P_n^k) = \min(n, k + 1)$
- If $n > k + 1$, then $\chi(C_n^k) = k + 1 + \lceil \frac{r}{q} \rceil$ where $n = q(k + 1) + r$ and $r \leq k$.
- $\chi(C_n^k) = n$ otherwise.

For the case of squares of graphs (i.e. $k = 2$), we have $\Delta(G^2) \leq \Delta(G)^2$ (and this can be tight). Therefore, applying Brooks' theorem on G^2 states that $\Delta(G)^2$ colors are sufficient excepted when G^2 is a clique on $\Delta(G)^2 + 1$ vertices. Such graphs are called *Moore graphs*, and there are only finitely many of them [4]. For all the other graphs, the $\Delta(G)^2$ bound can actually be improved, as shown by the following result.

Theorem 3 ([3]). *If G is not a Moore graph, then $\chi(G^2) \leq \Delta(G)^2 - 1$.*

These results have been generalized for higher powers of graphs. Assume that $k \geq 3$. Then, the maximum possible value of $\Delta(G^k)$ is $f(k, \Delta(G))$, where

$$f(k, \Delta) = \Delta \sum_{i=0}^{k-1} (\Delta - 1)^i = \Delta \frac{(\Delta - 1)^k - 1}{\Delta - 2}$$

is the number of nodes of a Δ -regular tree of height k , without its root. Thus, Brooks' theorem gives that $f(k, \Delta)$ colors are sufficient to color every graph G with maximum degree Δ , as soon as it is not a generalized Moore graph, i.e. G^k is not a clique on $f(k, \Delta) + 1$ vertices. However, such a graph does not exist when $k \geq 3$ [4]. Therefore, the bound $\chi(G^k) \leq f(k, \Delta)$ always holds. Moreover, as shown below, this upper bound can be lowered by 1.

Theorem 4 ([1]). *For $k \geq 3$ and every graph G , we have $\chi(G^k) \leq f(k, \Delta) - 1$.*

When $k = 2$, note that $f(2, \Delta) = \Delta^2$. Hence, together with Theorem 3, this result settles a conjecture of [5], stating that two colors can be spared from the naive upper bound $f(k, \Delta) + 1$, excepted when $k = 2$ and G is a Moore graph.

In [1], the authors conjecture that we can improve this result, by sparing k colors for higher values of k , excepted for a finite number of graphs.

Conjecture 5 ([1]). *For every $k \geq 2$, all but finitely many graphs G satisfy $\chi(G^k) \leq f(k, \Delta(G)) + 1 - k$.*

Towards this conjecture, we prove that most of the time, $k - 2$ colors can be spared:

Theorem 6. *For every k, Δ , there are only finitely many graphs G of maximum degree Δ such that $\chi(G^k) > f(k, \Delta) + 3 - k$.*

Note that Brooks' theorem gives an infinite list of graphs such that $\chi > \Delta$. However, for every $\Delta \geq 3$, this list contains only one graph of given maximum degree Δ . In this setting, Theorem 6 can be seen as a generalization of Brooks' theorem for powers of graphs. However, observe that the bounds we obtain for $k \leq 2$ are worse than those given by Brooks' theorem.

2 Overview of the proof

In this section, we give a proof of Theorem 6. First note that the case $k = 1$ is easy since every graph G can be colored with $\Delta(G) + 1 \leq f(1, \Delta) + 2$. Moreover, the case $k = 2$ is already handled by Theorem 3. Thus, we only consider the case $k \geq 3$. In the following, we denote by G a graph of maximum degree $\Delta \geq 3$ such that $\chi(G^k) > f(k, \Delta) + 3 - k$, if any.

To prove Theorem 6, we prove that G cannot have some configurations, until we get to the point where G is proved to lie in a finite set. For each of these configurations, assuming that G contains it, we design a procedure to give a valid coloring of G , and thus reach a contradiction. This procedure roughly consists in coloring the vertices greedily by decreasing distance to the configuration. We first apply this technique to prove that G is Δ -regular.

Lemma 7. *The graph G has minimum degree Δ .*

Proof. Assume that G has a vertex u of degree at most $\Delta - 1$. Let H be the graph obtained from G by attaching to u a pending path u_1, \dots, u_k . Observe that $\Delta(H) = \Delta$ since u has degree at most $\Delta - 1$ in G . To reach a contradiction, we color vertices of G in H in order corresponding to decreasing distance to u_k .

Note that, usually, we remove elements of G , and use some minimality argument to obtain a coloring to extend. In this case, we instead add some vertices. This is not related to some inductive argument (we do not even color these new vertices). The goal of this modification is to make the gap between the number of forbidden colors and the upper bound easier to find, by counting the uncolored vertices in the neighborhood at distance k instead.

Let v be a vertex of G , at distance d from u_k . Note that the d neighbors on a shortest path from v to u_k are uncolored. Thus, v has at most $f(k, \Delta) - d$ colored neighbors in G^k , hence v has at least $d - k + 3$ available colors. Since $v \in V(G)$, we have $d \geq k$, hence v can always be colored.

We thus obtain $\chi(G^k) \leq f(k, \Delta) - k + 3$, a contradiction. \square

We can prove in a similar fashion that G has large girth. Assuming that G has a small cycle, we color the vertices of G by decreasing distance to the cycle. Then, when only the cycle remains to be colored, each of its vertices has at least $p + 1$ available colors, where p is the length of the cycle. Thus we can prove the following.

Lemma 8. *The graph G has girth at least $k + 2$.*

To obtain Theorem 6, we actually prove that G has bounded diameter. Since the number of Δ -regular graphs with bounded diameter is finite, Theorem 6 thus boils down to proving the following lemma.

Lemma 9. *The graph G has diameter at most $2k - 1$.*

The remainder of this section is devoted to giving the main ideas of this proof. Assume that G contains two vertices u_1 and v_k at distance $2k$ from each other. Thus there is an induced path $P = u_1 \cdots u_k x v_1 \cdots v_k$ on $2k + 1$ vertices in G .

For $i \in \{1, \dots, k\}$, observe that $\text{dist}(u_i, v_i) = k + 1$ so we can give color i to u_i and v_i . We fix the following ordering of the vertices of P : $u_1 > v_k > u_2 > v_{k-1} > \cdots > u_k > v_1 > x$. For every remaining vertex v of G , we define the *root* r_v of v as the largest vertex of P on a shortest path between x and v (in case of equality, r_v is taken as one of the v_i 's).

We then color every uncolored vertex v of G by decreasing (lexicographic) order of $(r_v, \text{dist}(v, r_v))$. The goal is to prove that, each time we consider a vertex v , at most $f(k, \Delta) - k + 2$ colors are present on its neighbors. To this end, we count two objects:

- The p uncolored vertices in the neighborhood of v in G^k .
- The q colors appearing at least twice in the neighborhood of v in G^k .

Note that the number of forbidden colors is then at most $f(k, \Delta) - p - q$. Thus, if $p + q \geq k - 2$, we can always find an available color for v . Lemma 9 is obtained by counting $p + q$ for each vertex v we have to color. The main idea is that if v is far away from x , then p is high. Otherwise, many neighbors of v in G^k share the same color, and q is high.

When $r_v \neq x$, we show that $p \geq k - 2$. We find $k - 2$ uncolored vertices in the neighborhood of v , by considering three types of vertices, as shown in Figure 1. The number of vertices of each type depends on $\text{dist}(v, r_v)$ and $\text{dist}(r_v, x)$, but there are at least $k - 2$ of them.

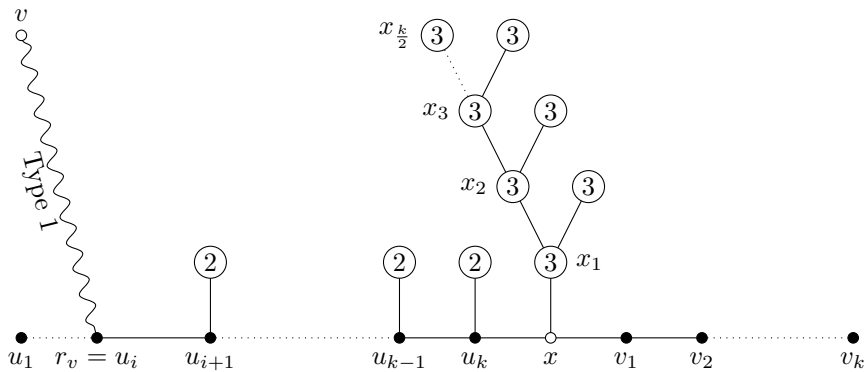

Figure 1: Global picture of the situation when considering v : black vertices are already colored, white ones are uncolored. Integers inside vertices represent types.

When $r_v = x$, then we again consider some cases: if $\text{dist}(v, x)$ is large enough, then p is large. Then, when $\text{dist}(v, x)$ gets smaller, p decreases but q increases. Indeed, when $\text{dist}(v, x) < \frac{k}{2}$, the vertex v is at distance at most k of vertices in P sharing the same color.

This ends the proof sketch of Theorem 6. As a final remark, observe that the proofs of Lemmas 7 and 8 are still valid both in the list coloring setting (since we use only degeneracy arguments) and in the case where we want to spare more colors (say at most k). This is not the case anymore for Lemma 9. However, maybe some more involved arguments could bound the diameter of G in these two more general settings.

3 Conclusion and open problems

We prove that we can spare roughly k colors from the naive lower bound when coloring k -th power of many graphs. However, the only known examples that do not satisfy the bound of Conjecture 5 have small Δ . A first question is thus to know whether the bound we obtain can be strengthened using different assumptions, for example $\Delta \geq 4$, or $\Delta \geq k$.

Another natural question is about the number of exceptions given by Theorem 6. We give here a proof that all possible counterexamples of our statement have diameter less than $2k - 1$, with no more insight on their structure. The coloring procedure we used to bound the diameter is quite simple, and considering more involved patterns (instead of a long path) could lead to much structure and hence a better bound.

Finally, Conjecture 5 has been stated in the list coloring setting. The arguments we use do not translate directly to this wider setting, and it would probably be interesting to determine whether Theorem 6 can be extended or not.

References

- [1] Bonamy M. and Bousquet N., *Brooks' theorem on powers of graphs*, Discrete Math. **325** (2014), 12–16.
- [2] Brooks R.L., *On colouring the nodes of a network*, Math. Proc. Cambridge Philos. Soc. **37** (1941), 194–197.
- [3] Cranston D.W. and Rabern L., *Painting Squares in $\Delta^2 - 1$ Shades*, Electron. J. Combin. **23** (2016), 2–50.
- [4] Hoffman A.J. and Singleton R.R., *On Moore graphs with diameters 2 and 3*, IBM Journal of Research and Development **4** (1960), 497–504.
- [5] Miao L.Y. and Fan Y.Z., *The distance coloring of graphs*, Acta Math. Sin. (Engl. Ser.) **30** (2014), 1579–1587.
- [6] Prowse A. and Woodall D.R., *Choosability of powers of circuits*, Graphs Combin. **19** (2003), 137–144.

On the Minimum Skewness of Certain Classes of Graphs

Val Pinciu

Department of Mathematics
Southern Connecticut State University
New Haven, CT, U.S.A.

EXTENDED ABSTRACT

1 Introduction

Throughout this paper, $G = (V, E)$ denotes a connected simple graph with vertex set $V = V(G)$ and edge set $E = E(G)$. G is *planar* if it can be embedded in the plane, i.e., it can be drawn on the plane such that no edges cross each other. The *crossing number* $cr(G)$ of a simple graph $G = (V, E)$ is the minimum number of edge crossings in any drawing of G in the plane. The *skewness* $\mu(G)$ of a simple graph $G = (V, E)$ is the minimum number of edges whose removal makes the graph planar. It is obvious that $\mu(G) \leq cr(G)$. However the skewness and the crossing number of a graph can differ widely, since $\mu(G)$ can be of size $O(|V|^2)$, while $cr(G)$ can be as large as $O(|V|^4)$. A general lower bound for the skewness of a graph is given by the following:

Theorem 1 ([13]) *If $G = (V, E)$ is a connected simple graph with girth $g \geq 3$ then:*

$$\mu(G) \geq |E| - \frac{g(|V| - 2)}{g - 2}.$$

Equality holds if and only if G has a spanning planar subgraph that is face-regular of degree g .

It is easy to use Theorem 1 to show that Petersen's Graph has skewness and crossing number 2, while Heawood's Graph has skewness and crossing number 3. It is less obvious to show that Grötzsch's Graph has skewness 3 and crossing number 5 (for more information see [13]). However, an exact formula for the skewness of an arbitrary nonplanar graph is unknown:

Theorem 2 ([10]) *Determining the skewness of an arbitrary nonplanar graph is NP-complete.*

Exact formulae are known for several classes of graphs, including the complete graphs on n vertices K_n , and the complete bipartite graphs on $m + n$ vertices $K_{m,n}$:

Theorem 3 ([9]) *If K_n and $K_{m,n}$ are the complete graph on n vertices and the complete bipartite graph on $m + n$ vertices respectively, then:*

1. $\mu(K_n) = \frac{(n-3)(n-4)}{2}$
2. $\mu(K_{m,n}) = mn - 2(m + n) + 4$

In this paper we investigate the relationship between the skewness, the minimum degree, and the chromatic number of a graph. In Section 2 we show that among all graphs with minimum degree $n \geq 6$, the complete graph on $n + 1$ vertices K_{n+1} is the one with the smallest skewness, and among all triangle-free graphs with minimum degree $n \geq 4$, the complete bipartite graph on $2n$ vertices $K_{n,n}$ is the one with the smallest skewness. We also consider graphs with girth 5 or higher. In Section 3 we show that among all graphs requiring n colors, the complete graph on n vertices K_n is the one with the smallest skewness.

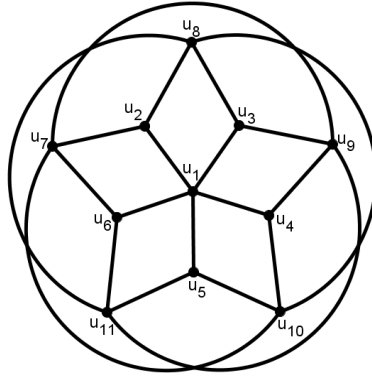

Figure 1: The Grötzsch graph has skewness 3 and crossing number 5.

2 Skewness and Minimum Degree

In this section we investigate the relationship between the skewness and the minimum degree of a graph.

Theorem 4 *Let G be any simple graph and let $n \geq 7$ be a positive integer.*

If $\delta(G) \geq n - 1$, then $\mu(G) \geq \mu(K_n)$.

The following result holds for triangle-free graphs:

Theorem 5 *Let G be any simple triangle-free graph and let $n \geq 4$ be a positive integer. If $\delta(G) \geq n$, then $\mu(G) \geq \mu(K_{n,n})$.*

It is easy to see that the conclusions of Theorems 4 and 5 do not hold when $n = 6$ and $n = 3$ respectively. The following results hold for graphs of girth 5 and 6 respectively.

Theorem 6 *If G has girth 5 and $\delta(G) \geq 4$, then $\mu(G) \geq 10$.*

Theorem 7 *If G has girth 6 and $\delta(G) \geq 3$, then $\mu(G) \geq 3$.*

3 Skewness and Chromatic Number

In this section we investigate the relationship between the skewness and the chromatic number of a graph. Here is our main result:

Theorem 8 *Let G be any simple graph and let n be any positive integer.*

If $\chi(G) \geq n$ then $\mu(G) \geq \mu(K_n)$.

The statement is trivial when $n \leq 4$, is equivalent to the Four Color Theorem when $n = 5$, and is equivalent to a generalization of the Five Color Theorem by Kainen [8] when $n = 6$ since $\mu(K_6) = 3$. The statement follows from Theorem 4 by induction on $|V|$ when $n \geq 7$.

We note that a conjecture by Albertson, where the skewness in Theorem 8 is replaced by the crossing number is still open for $n > 16$:

Conjecture 9 ([1], [4]) *Let G be any simple graph and let n be any positive integer.*

If $\chi(G) \geq n$ then $cr(G) \geq cr(K_n)$.

In [14], the author notes that if we replace the skewness in Theorem 8 with the genus $\gamma(G)$ (the minimum genus of the orientable surface on which G is embeddable), we obtain a true statement that easily follows from Heawood's upper bound for the chromatic number of a graph embeddable on an orientable surface of a given genus [5] and the Ringel-Youngs Theorem [15]:

Theorem 10 *Let G be any simple graph and let n be any positive integer.*

If $\chi(G) \geq n$ then $\gamma(G) \geq \gamma(K_n)$, where $\chi(G)$ is the chromatic number of G .

Also In [14], the author notes that if we replace the skewness in Theorem 8 with the thickness $\theta(G)$ (the minimum number of planar subgraphs of G whose union is G), the corresponding statement "if $\chi(G) \geq n$ then $\theta(G) \geq \theta(K_n)$ " is not true for all n . The Sulanke graph $K_{11} - C_5$ is a counterexample when $n = 9$. When $n = 10, 11$, or 12 , determining the truth value of this statement is equivalent to Ringel's famous Earth-Moon problem. However, the corresponding statement is true for infinitely many values of n :

Theorem 11 *Let G be any simple graph and let $n \geq 13$ be a positive integer such that $n \equiv 1, 2, 3$, or $4 \pmod{6}$.*

If $\chi(G) \geq n$ then $\theta(G) \geq \theta(K_n)$, where $\chi(G)$ is the chromatic number of G .

References

- [1] M.O. Albertson, D.W. Cranston and J. Fox, Crossings, Colorings and Cliques, *Electron. J. Combin.*, **16** (2009) #R45.
- [2] V. B. Alekseev and V. S. Gonchakov, Thickness of Arbitrary Complete Graphs, *Mat. Sbornik* **101** (1976), 212–230.
- [3] K. Appel and W. Haken, Every Planar Map is Four Colorable, Part I. Discharging, *Illinois J. Math.*, **21** (1977), 429–490.
- [4] J. Barat and G. Toth, Towards the Albertson Conjecture, *Electron. J. Combin.*, **17** (2010) #R73.
- [5] P. J. Heawood, Map Colour Theorem, *Quarterly Journal of Mathematics* **24** (1890), 332–338.
- [6] M. Gardner, Mathematical games, *Sci. Amer.*, **242** 1980, 14–19.
- [7] T. Jensen and B. Toft, *Graph coloring problems*, Wiley-Interscience Series in Discrete Mathematics and Optimization, John Wiley & Sons Inc., New York, 1995.
- [8] P. Kainen, A Generalization of the 5-Color Theorem, *Proc. Amer. Math. Soc.* **45** (1974), 450–453.
- [9] A. Kotzig, On a Certain Decomposition of a Graph, *Mat.-Fyz. Čaposis* **5** (1955), 144–151.
- [10] P. C. Liu and R. C. Gelmacher, On the Deletions of Nonplanar Edges of a Graph, *Congressus Numerantium* **24** (1979), 727–738.
- [11] A. Mansfeld, Determining the Thickness of a Graph is NP-Hard, *Math. Proc. Cambridge Philos. Soc.* **93** (1983), 9–23.
- [12] B. Oporowski, D. Zhao, Coloring graphs with crossings, *Discrete Math.*, **309** (2009), 2948–2951.
- [13] V. Pinciu and W. Soss, A Note on the Skewness of a Graph, *Congressus Numerantium* **227** (2016), 209–214.
- [14] V. Pinciu, Colorings, Cliques and Relaxations of Planarity, to appear in *Matemática Contemporânea*.
- [15] G. Ringel and J. M. Youngs, Solution of the Heawood Map-Coloring Problem, *Proc. Nat. Acad. Sci. USA* **60** (1968), 438–445.

- [16] N. Robertson, The Smallest Graph of Girth 5 and Valency 4, *Bull. Amer. Math. Soc.* **70** (1964) 824–825.
- [17] N. Robertson, D.P. Sanders, P.D. Seymour, and R. Thomas, The Four-Color Theorem, *J. Combin. Theory Ser. B* **70** (1997), 2–44.
- [18] C. Thomassen, The graph genus problem is NP-complete, *Journal of Algorithms* **10** (4) (1989), 568–576.

The 1–2–3 Conjecture and regular graphs

Jakub Przybyto

AGH University of Science and Technology,
al. A. Mickiewicza 30, 30-059 Krakow, Poland

EXTENDED ABSTRACT

1 Irregularity strength and the 1–2–3 Conjecture.

Regular graphs are well defined and understood objects. This is however not the case with their antonyms, which one could call irregular graphs. Actually it is a well-known fact that there are no such things, understood as graphs with pairwise distinct vertex degrees, except the trivial 1-vertex graphs. In [7] Chartrand, Erdős and Oellermann proposed a few alternative definitions of such objects in their paper entitled ‘*How to Define an Irregular Graph*’; while Chartrand et al. [8] turned towards measuring the level of irregularity of graphs instead. Capitalizing in particular on the fact that there are plenty *irregular multigraphs* (multigraphs with pairwise distinct degrees), they asked for a given graph $G = (V, E)$ what is the minimum k such that we may obtain an irregular multigraph of G by blowing each edge e of G into at most k parallel copies of e . This value was called the *irregularity strength* of a graph, and was investigated in numerous papers, see e.g.[3, 8, 10, 11, 13]. The same concept was in an obvious way alternatively defined in the language of graph weightings or labellings as the least k for which there exists a k -weighting $\omega : E \rightarrow \{1, 2, \dots, k\}$ of the edges of G such that every vertex v in V receives a distinct *weighted degree*:

$$d_\omega(v) = \sum_{e \ni v} \omega(e),$$

that is the sum of its incident weights. The irregularity strength constitutes also the cornerstone of the now vast branch within the discipline of graph colourings and labellings. One of the most well known problems directly related with the irregularity strength was its local variant, where the distinction $d_\omega(u) \neq d_\omega(v)$ is required only for the neighbours in G , i.e. in the case when $uv \in E$. If this holds for any given k -weighting of the edges of G , we say that G is k -weight colourable (as in particular d_ω defines a proper vertex colouring of G then). This concept was proposed by Karoński, Łuczak and Thomason in [15], where the authors asked a very intriguing and simply formulated question many researchers have been trying to answer since then, which is usually referred to as the *1–2–3 Conjecture* in the literature nowadays.

Conjecture 1 (1–2–3 Conjecture) *Every graph without isolated edges is 3-weight colourable.*

In other words they suspected that for all such graphs, it is enough to use just weights 1,2,3 in order to distinguish adjacent vertices with their associated sums – the weighted degrees.

2 Crucial results concerning the 1–2–3 Conjecture.

In the first paper concerning this problem the authors did not provide any finite bound supporting their suspicion; though they confirmed the conjecture e.g. for the case of graphs with chromatic number at most 3, and proved a finite set of 183 real numbers admitted as weights would suffice for all graphs without isolated edges. The first general upper bound was later proved by Addario-Berry, Dalal, McDiarmid, Reed and Thomason, who showed that weights in the set $\{1, 2, \dots, 30\}$ are sufficient, using a theorem on so-called degree-constrained subgraphs, see [1]. This set was then narrowed down by Addario-Berry, Dalal and Reed [2] to $\{1, 2, \dots, 16\}$ and next to $\{1, 2, \dots, 13\}$ by Wang and Yu [20], who used a similar technique as the authors of [1]. Interestingly, it was also proved in [2] that a random graph (chosen from

$G_{n,p}$ for a constant p) is asymptotically almost surely already 2-weight colourable. Dudek and Wajc [9] however verified that deciding whether a given graph without an isolated edge is 2-weight colourable is NP-complete. On the other hand, as showed by Thomassen, Wu and Zhang [19], the same problem can be solved in polynomial time in the class of bipartite graphs, which were all nicely characterized by them in terms of their weight-colourability. The 1–2–3 Conjecture was also quite recently confirmed by Zhong [23] for very dense graphs with minimum degree at least $0.99985|V|$. Before I turn to the main known general result in this area and our contribution, I will mention a different problem, whose formulation was crucial for obtaining these results.

3 Total and list weightings.

In [17] Przybyło and Woźniak proposed the natural total variant of the 1–2–3 Conjecture, where one additionally assigns a weight to every vertex v of G , which then is counted in the weighted degree of v , and asked if maybe in this case, every graph is totally 2-weight colourable. This was later almost solved by Kalkowski [12] by means of a very inventive yet surprisingly simple deterministic algorithm, which implied that it is in fact sufficient to use just weights in $\{1, 2, 3\}$ for the edges and weights in $\{1, 2\}$ for the vertices of any graph. This result was then generalised by a beautiful paper of Wong and Zhu [22], who proved that the same holds also in a natural list version of the problem investigated by Kalkowski. To achieve this, Wong and Zhu applied an elegant algebraic approach exploiting graph polynomials and Alon’s Combinatorial Nullstellensatz (see [4]). Such approach was first proposed in the context of the 1–2–3 Conjecture by Bartnicki, Grytczuk and Niwczyk, see [5]; we mention a few conjectures related with this direction at the end of the extended abstract.

4 Main results.

It was Kalkowski’s algorithm from [12] that inspired the best known upper bound concerning the 1–2–3 Conjecture, and actually a modification of a general idea behind this algorithm enabled Kalkowski, Karoński and Pfender to prove the following.

Theorem 2 ([14]) *Every graph without isolated edges is 5-weight colourable.*

Our main contribution is the following.

Theorem 3 *Every d -regular graph with $d \geq 2$ is 4-weight colourable.*

This is in fact the main result of a short note [16], which we would like to fully present during the talk. It is worth noting that this was previously known for $d \in \{2, 3\}$ by [15] and for $d = 5$ by the result of Bensmail [6]. The main idea of the proof of Theorem 3 is based on first choosing a maximal independent set I in a given graph G and then dividing the remaining vertices into two subsets S_1 and S_2 , the first consisting of these vertices which have no neighbours outside I and the second including all the remaining vertices. We then choose appropriate starting weights for all the edges in the graph and apply in some sense a variant of Kalkowski’s algorithm to distinguish the sums of the vertices in S_2 , carefully enough though to keep the weighted degrees in this set relatively small. In fact these shall be all smaller than the weighted degrees in our chosen maximal independent set I . At the end of the proof we analyze all the remaining vertices – those in S_1 , switching weights of their incident edges to get read of all the possible remaining conflicts in the graph, see details in [16].

5 Further problems.

At the end we present a few aforementioned related conjectures. The first is a direct and natural list generalisation of the 1–2–3 Conjecture due to Bartnicki, Grytczuk and Niwczyk, see [5] for details

Conjecture 4 ([5]) *Every graph without isolated edges is 3-weight choosable.*

Despite the result of Wong and Zhu [21] a similar list problem is also far from being solved in the total setting. There are two main conjectures here the first of which was posed independently in two papers.

Conjecture 5 ([18, 22]) *Every graph is totally weight choosable from any lists (of real numbers) of size 2 associated to its edges and vertices.*

Conjecture 6 ([18, 22]) *Every graph without isolated edges is totally weight choosable from any lists (of real numbers) of size 3 associated to its edges and size 1 associated to its vertices.*

Note that the last conjecture is a direct strengthening of Conjecture 4.

References

- [1] L. Addario-Berry, K. Dalal, C. McDiarmid, B.A. Reed, A. Thomason. Vertex-Colouring Edge-Weightings. In **Combinatorica** 27:1–12, 2007.
- [2] L. Addario-Berry, K. Dalal, B.A. Reed. Degree Constrained Subgraphs. In **Discrete Appl. Math.** 156:1168–1174, 2008.
- [3] M. Aigner, E. Triesch. Irregular assignments of trees and forests. In **SIAM J. Discrete Math.** 3:439–449, 1990.
- [4] N. Alon. Combinatorial Nullstellensatz. In **Combin. Probab. Comput.** 8:7–29, 1999.
- [5] T. Bartnicki, J. Grytczuk, S. Niwczyk. Weight Choosability of Graphs. In **J. Graph Theory** 60:242–256, 2009.
- [6] J. Bensmail. A 1-2-3-4 result for the 1-2-3 Conjecture in 5-regular graphs. In **Discrete Appl. Math.** 257:31–39, 2019.
- [7] G. Chartrand, P. Erdős, O. R. Oellermann. How to Define an Irregular Graph. In **College Math. J.** 19:36–42, 1988.
- [8] G. Chartrand, M. S. Jacobson, J. Lehel, O. R. Oellermann, S. Ruiz, F. Saba. Irregular networks. In **Congr. Numer.** 64:197–210, 1988.
- [9] A. Dudek, D. Wajc. On the complexity of vertex-coloring edge-weightings. In **Discrete Math. Theor. Comput. Sci.** 13:45–50, 2011.
- [10] R.J. Faudree, J. Lehel. Bound on the irregularity strength of regular graphs. In **Colloq Math Soc Jaños Bolyai, 52, Combinatorics, Eger North Holland, Amsterdam,** 247–256, 1987.
- [11] A. Frieze, R.J. Gould, M. Karoński, F. Pfender. On Graph Irregularity Strength. **J. Graph Theory** 41:120–137, 2002.
- [12] M. Kalkowski. A note on 1,2-Conjecture. in Ph.D. Thesis, Poznań, 2009.
- [13] M. Kalkowski, M. Karoński, F. Pfender. A new upper bound for the irregularity strength of graphs. In **SIAM J. Discrete Math.** 25:1319–1321, 2011.

- [14] M. Kalkowski, M. Karoński, F. Pfender. Vertex-coloring edge-weightings: Towards the 1-2-3 conjecture. In **J. Combin. Theory Ser. B** 100:347–349, 2010.
- [15] M. Karoński, T. Łuczak, A. Thomason. Edge weights and vertex colours. In **J. Combin. Theory Ser. B** 91:151–157, 2004.
- [16] J. Przybyło. The 1–2–3 Conjecture almost holds for regular graphs. arXiv:1809.10761.
- [17] J. Przybyło, M. Woźniak. On a 1,2 Conjecture. In **Discrete Math. Theor. Comput. Sci.** 12:101–108, 2010.
- [18] J. Przybyło, M. Woźniak. Total weight choosability of graphs. In **Electron. J. Combin.** 18:#P112, 2011.
- [19] C. Thomassen, Y. Wu, C.Q. Zhang. The 3-flow conjecture, factors modulo k , and the 1-2-3 conjecture. In **J. Combin. Theory Ser. B** 121:308–325, 2016.
- [20] T. Wang, Q. Yu. On vertex-coloring 13-edge-weighting. In **Front. Math. China** 3:581–587, 2008.
- [21] T. Wong, X. Zhu. Every graph is (2,3)-choosable. In **Combinatorica** 36:121–127, 2016.
- [22] T. Wong, X. Zhu. Total weight choosability of graphs. In **J. Graph Theory** 66:198–212, 2011.
- [23] L. Zhong. The 1-2-3-conjecture holds for dense graphs. In **J. Graph Theory** 90:561–564, 2019.

Distinguishing vertices of a graph - palettes and automorphisms

Mariusz Woźniak

Department of Discrete Mathematics, AGH University, Cracow, Poland

EXTENDED ABSTRACT

The aim of the talk is discussion about the relationship between two different approaches to the problem of distinguishing vertices of a graph.

Let $G = (V, E)$ be a graph of order n . The function $f : E(G) \mapsto \{1, 2, \dots, k\}$ is called an *edge coloring*. Any such coloring assigns to the vertices of a graph *palette of colors*, i.e. the set of colors on incident edges. In general, this coloring does not have to be proper, but we will only consider the proper ones.

Two vertices are called *similar* if they have the same palettes. Coloring *distinguishes all vertices* if there are no two similar vertices. Observe that if G contains more than one isolated vertex or any isolated edges, then no coloring of G is vertex-distinguishing. We will consider only connected graphs with $n \geq 3$.

A completely different approach to coloring distinguishing all vertices refers to the concept of automorphism. This approach is not related to local properties. It's about colorings that break down all non-trivial automorphisms. Over twenty years ago, Albertson and Collins (see [1]) initiated investigations of distinguishing colorings, where "distinguishing" means "symmetry breaking". They were looking for the least number of colors in a vertex coloring (not necessarily proper) of a graph that is preserved only by the trivial automorphism. In other words, such a coloring breaks every automorphism different from the identity, and it distinguishes vertices of a graph in this sense. The proper coloring was considered in this context for the first time by Collins and Trenk (see [7]).

Interestingly, the edge version appeared relatively recently. A few years ago, Kalinowski and Piłśniak (see [8]) initiated studying distinguishing edge colorings. This new concept met quite a big interest within specialists working on distinguishing vertex colorings. Moreover, they extended this concept also to a proper coloring. In this case, the corresponding parameter is called *the distinguishing chromatic index* and is denoted by χ'_D . Recently, this idea was extended also to the case of total colorings in [10] where the corresponding parameter is denoted by χ''_D .

The minimum number of colors required to find a vertex-distinguishing coloring of a graph G without isolated edges and with at most one isolated vertex is called the *vertex-distinguishing index* and is denoted by $\text{vdi}(G)$.

This index was introduced and studied by Burriss and Schelp in [5] and, independently, by Černý, Horňák and Soták in [6] (see also [4], [2]).

Among the graphs G for which we know the value of $\text{vdi}(G)$, the largest value is realized when $G = K_n$ with n even and equals $n + 1$. The paper [3] contains the proof that inequality $\text{vdi}(G) \leq n + 1$ holds for all graphs.

Since an automorphism of a connected graph G preserving colors preserves also palettes we have (for a connected graph G of order at least three):

$$\chi'_D(G) \leq \text{vdi}(G).$$

However, for some families of graphs, the difference between parameters can be significant. For instance, let us consider a vertex-distinguishing coloring of a cycle of length n with k colors. Since each palette is of size two, and the number of all possible palettes should be not smaller than n , we have $\binom{k}{2} \geq n$. Thus, $\text{vdi}(C_n) \geq \sqrt{2n}$.

Note, however, that for cycles C_n , $n \geq 7$, three colors are enough to get a coloring that breaks non-trivial automorphism. Two examples are given in Figure 1.

The authors of the paper [9] proposed to distinguish the vertices by another way: we shall be able to compare not only the palettes of given vertices, but also to move using color-walks

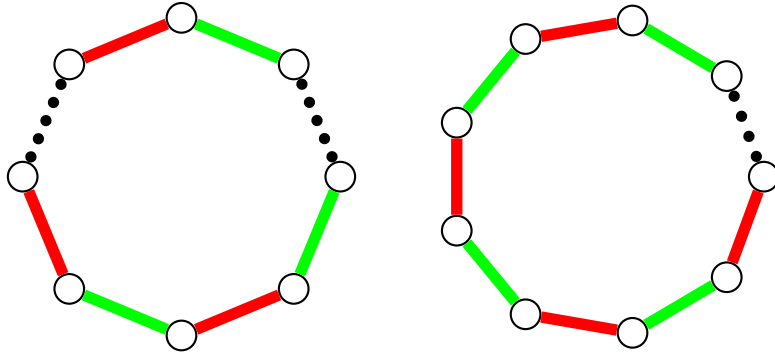

Figure 1: Two 3-coloring breaking all nontrivial automorphisms.

and compare the palettes in attained vertices. We need some definitions. For given vertex $x \in V$, each walk emanating from x defines a sequence of colors. The set of all color sequences obtained in this way is denoted by $W(x)$. We say that two vertices x and y are *similar* if $W(x) = W(y)$. The coloring f *personalizes (distinguishes)* the vertices of G if there is no similar vertices. The minimum number of colors we need to obtain this property is denoted by $\mu(G)$.

Evidently, a vertex-distinguishing coloring personalizes the vertices of G . Moreover, it suffices to use the walks of length one. However, if we are allowed to use the walks of arbitrary length, the number of colors we need is surprisingly small. We have the following theorem (see [9]).

Theorem 1 *Let G be a connected graph of order $n \geq 3$. Then*

$$\mu(G) \leq \Delta(G) + 1$$

except for seven graphs of small order: C_4 , K_4 , C_6 , $K_3 \square K_2$, $K_{3,3}$, $K_6 - M$ (the complete graph with a perfect matching removed) and K_6 .

The paper [10] concerns the transfer of this result to the case of proper total coloring (with evident definitions of color walks, etc.) and contains the following result.

The minimum number of colors we need to obtain a coloring without similar vertices is now denoted by $\mu^t(G)$.

Theorem 2 *Let G be a connected graph. Then*

$$\mu^t(G) \leq \chi''(G) + 1.$$

Moreover, if $\chi''(G) \geq \Delta(G) + 2$ then $\mu^t(G) = \chi''(G)$.

In the case of proper vertex coloring (again with evident definitions of color walks, etc.), the minimum number of colors we need to obtain a coloring without similar vertices is denoted by $p(G)$.

Theorem 3 *Let G be a connected graph of order n . Then*

$$p(G) \leq 2\Delta(G).$$

In general, this bound cannot be improved. It is worth noting that Collins and Trenk, showed in [7] that $\chi_D \leq 2\Delta(G)$ for a connected graph of order n where χ_D denote the minimum number of colors in a proper vertex coloring of a graph G breaking all nontrivial automorphisms.

Since an automorphism of a connected graph G preserving colors preserves also color walks we have (for a connected graph G of order at least three):

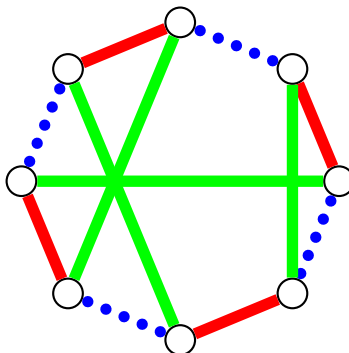

Figure 2: A 3-coloring breaking all nontrivial automorphisms with all vertices having the same set of color walks

- $\chi'_D(G) \leq \mu(G)$
- $\chi''_D(G) \leq \tau(G)$
- $\chi_D(G) \leq p(G)$

Note that, for example, in the case of edge coloring, we have even equality for class II graphs. In general, the equality does not hold as the example in Figure 2 shows.

References

- [1] M. O. Albertson, K. L. Collins, Symmetry breaking in graphs, In **Eletron. J. Combin.** 3 (1996) R18.
- [2] P.N. Balister, E. Győri, L. Lehel and R. H. Schelp, Adjacent vertex distinguishing edge-colorings, In **SIAM J. Discrete Math.** 21 (2007) 237–250.
- [3] C.Bazgan, A.Harkat-Benhamdine, H.Li and M.Woźniak, On the vertex-distinguishing proper edge-colorings of graphs, In **J. Combin. Theory, Series B** 75 (1999), 288–301.
- [4] C. Bazgan, A. Harkat-Benhamdine, H. Li, M. Woźniak, A note on the vertex-distinguishing proper colorings of graphs with large minimum degree, In **Discrete Math.** 236 (2001), 37–42.
- [5] A. C. Burris and R. H. Schelp, Vertex-distinguishing proper edge-colorings, In **J. Graph Theory** 26(2) (1997), 73–82.
- [6] J. Černý, M. Horňák and R. Soták, Observability of a graph, In **Math. Slovaca** 46 (1996), 21–31.
- [7] K. L. Collins and A. N. Trenk, The distinguishing chromatic number, In **Electron. J. Combin.** 13 (2006) R16.
- [8] R. Kalinowski, M. Piłśniak, Distinguishing edge-colourings of a graph, In **European J. Combin.** 45 (2015), 124–131.
- [9] R. Kalinowski, M. Piłśniak, J. Przybyło and M. Woźniak, How to personalize the vertices of a graph?, In **European J. Combin.**, 40 (2014), 116–123.
- [10] R. Kalinowski, M. Piłśniak, M. Woźniak, Distinguishing graphs by total colourings, In **Ars Mathematica Contemporanea** 11 (2016), 79–89.

Authors

Abreu, Marien	10	González-Moreno, Diego	146
Andres, Stephan Dominique	14	Granhölm, Jonas	106, 108
Aranda, Andrés	18	Guevara, Mucuy-kak	146
Bagan, Guillaume	22	Hahn, Geňa	150
Balbuena, Camino	26, 30	Hakanen, Anni	151
Bang-Jensen, Jørgen	34	Heinlein, Matthias	155
Bartier, Valentin	38	Hell, Pavol	81, 85
Baste, Julien	42, 45, 48	Henning, Michael A.	42, 45
Beaudou, Laurent	52	Hocquard, Hervé	136
Bellitto, Thomas	34	Høgemo, Svein	159
Bessy, Stéphane	55	Hubička, Jan	163, 167
Bidine, Ez-Zobair	58	Huggan, Melissa	14
Blanchard, Nikola K.	73, 77	Jacques, Fabien	171
Blanché, Alexandre	62	Jedličková, Nikola	81, 85
Bok, Jan	81, 85	Joffard, Alice	22
Bonamy, Marthe	65, 88	Joos, Felix	132
Bousquet, Nicolas	38	Joret, Gwenaël	99
Brandt, Axel	92	Junnila, Ville	151
Brešar, Boštjan	143	Kachanovich, Siargey	73, 77
Brewster, Richard	52, 81	Kang, Ross	6
Bujtás, Csilla	69	Kardoš, František	175
Cameron, Kathie	96	Kawarabayashi, Ken-ichi	179
Cames van Batenburg, Wouter	99	Kchikech, Mustapha	58, 183
Carreño, José Juan	103	Kerivin, Hervé	187
Casselgren, Carl Johan	106, 108	Khatri, Devvrit	191
Chaplick, Steven	110	Kheddouci, Hamamache	22
Chepoi, Victor	114	Knauer, Kolja	114
Comellas, Francesc	118	Knop, Dušan	110
Courcelle, Bruno	122	Konečný, Matěj	163, 167
Dabrowski, Konrad K.	125	Kotani, Keiko	194
Dalfó, Cristina	26, 30	Kowalik, Łukasz	6
Dourado, Mitre C.	128	Krim-Yee, Aaron	191
Dross, François	14, 212	Kumar, Nithish	191
Ehard, Stefan	132	La, Hoang	196
Fomin, Fedor	110	Labbate, Domenico	10
Foucaud, Florent	52, 136	Laihonen, Tero	151
Fürst, Maximilian	42, 45, 48	Lajou, Dimitri	136
Gangloff, Silvère	140	Leclerc, Etienne	200
Gastineau, Nicolas	143	Limnios, Stratis	204
Gavoille, Cyril	65	Loudiki, Laila	183
Glock, Stefan	132	Lužar, Borut	212
Goedgebeur, Jan	10, 99	Lukočka, Robert	208
Golovach, Petr	110	Maceková, Mária	212
		MacGillivray, Gary	191, 200

Maezawa, Shun-ichi	215	Thilikos, Dimitrios M.	204
Martínez, José Antonio	103	Togni, Olivier	143
Martínez-Barona, Berenice	26, 30	Tuza, Zsolt	69
Masařík, Tomáš	125, 218	Uitto, Jara	88
Matsuda, Haruhide	215	Ulmer, Arthur	155
Mazzuoccolo, Giuseppe	10	Vågset, Erlend Raa	159
Mc Inerney, Fionn	14	Valicov, Petru	196
Métivier, Yves	122	Virgile, Virgélot	191
Mitchell, Bohdana	52	Vušković, Kristina	7
Mitsou, Valia	136	Wagler, Annegret	187
Mizuta, Haruka	62	Woźniak, Mariusz	243
Mohar, Bojan	179	Xu, AnQi	191
Mohr, Elena	42, 45	Yeo, Anders	34
Mohr, Samuel	222	Yerger, Carl	92
Montassier, Mickael	171, 196	Zeman, Peter	110, 179
Montellano-Ballesteros, Juan José	146		
Muzi, Irene	218		
Nakamura, Shunsuke	224		
Narboni, Jonathan	175		
Nešetřil, Jaroslav	6, 163, 167		
Nedela, Roman	179		
Novotná, Jana	125		
Nowakowski, Richard J.	14		
Ouvrard, Paul	62, 88		
Papalamprou, Konstantinos	228		
Paul, Christophe	204		
Paulusma, Daniël	125		
Penso, Lucia D.	128		
Perret, Joanny	204		
Philibert, Manon	114		
Pierron, Théo	136, 231		
Pilipczuk, Marcin	218		
Pilipczuk, Michał	65		
Pinciu, Val	235		
Pinlou, Alexandre	171, 196		
Przybyło, Jakub	239		
Puertas, María Luz	103, 151		
Rabie, Mikaël	88		
Raspaud, André	106, 108		
Rautenbach, Dieter	42, 45, 48, 55, 128		
Rzążewski, Paweł	125, 218		
Sánchez, Llorenç	118		
Seamone, Ben	191		
Škoviera, Martin	7		
Sorge, Manuel	218		
Soták, Roman	212		
Stein, Maya	7		
Suomela, Jukka	88		
Suzuki, Akira	62		
Talon, Alexandre	140		
Telle, Jan Arne	159		
Tenpas, Nathan	92		
Tětek, Jakub	208		